

NQKSF[®]

OIL SEAL 油封
O-RING O型圈

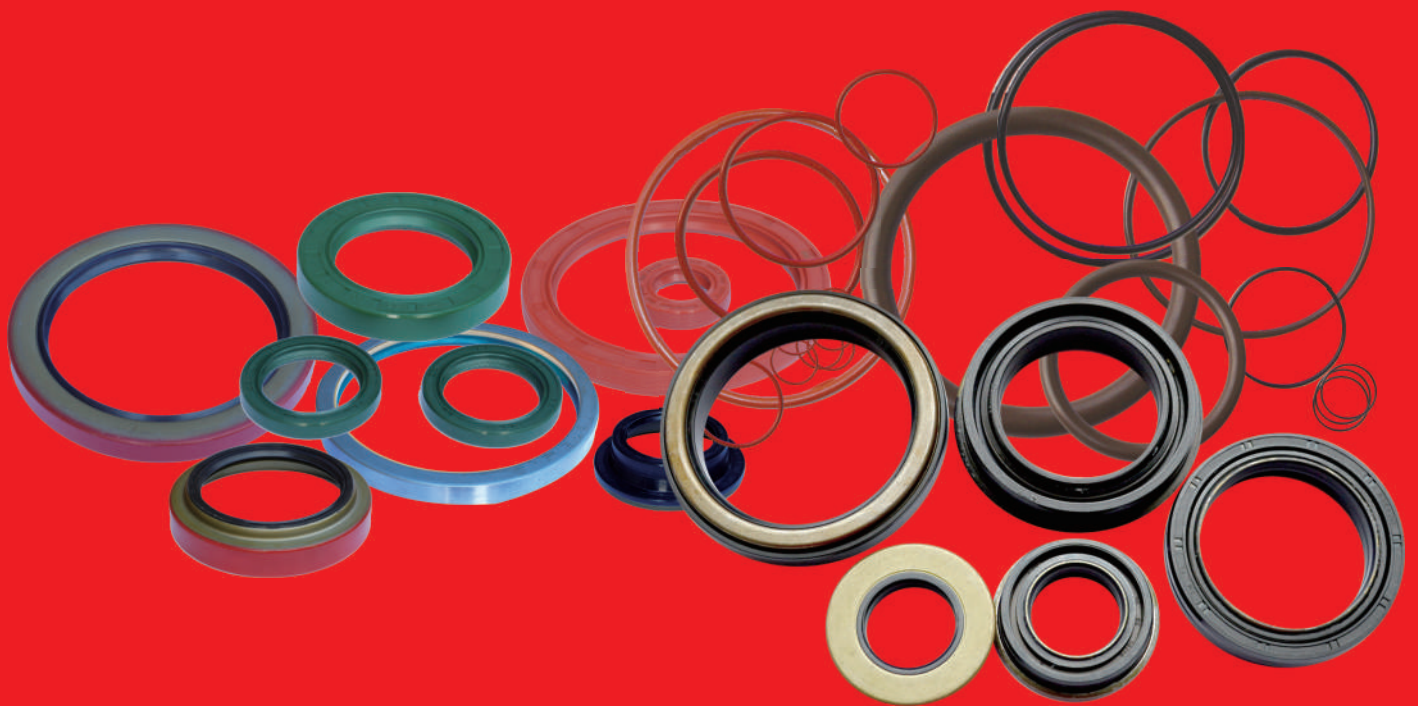

邢台山峰特种橡胶制品有限公司

XINGTAI SHANFENG SPECIAL RUBBER PRODUCT CO.,LTD



邢台山峰特种橡胶制品有限公司成立于1990年，深耕密封行业30年，是一家专注于研发制造油封和O型圈以及各类密封件产品的生产厂家。创立的自主品牌是“NQKSF”。

公司引进SAP的ERP管理系统和MES执行系统，严格执行ISO 9001和TS16949国际管理体系认证标准。

生产设备高度自动化，拥有强大生产制造能力，大大的提高了生产效率，大幅度缩短了生产周期。

公司拥有先进的研发检测设备，配备了高标准现代化实验室。

产品广泛应用于汽车，农机，电机，减速机，液压气动，钢厂，煤矿，化工等各种机械制造业，已销往亚洲、欧洲、美洲大洋洲的90多个国家。

山峰的宗旨：

把产品做精，做专！把企业做强，做大，做久！

Xingtai Shanfeng Special Rubber Products Co., Ltd was founded in 1990, which specially Research and Develop rubber oil seals and O-rings more than 30 years. Our own brand is "NQKSF".

We introduce SAP's ERP management system and MES implementation system, and strictly implement ISO 9001 and TS16949 international management system certification standards.

With highly automated equipment and strong manufacturing capacity. It improve the production efficiency and shorten production period.

We introduce advanced testing and R&D equipment to build a high standard oil seal modern laboratory.

Our products are widely used in automobile , agricultural, hydraulic pneumatic, steel plant, coal mine, chemical and other machinery manufacturing. They have been exported to more than 90 countries in Asia, Europe, North America and South America.

NQKSF Slogan:

Oil Seals , Be professional and excellent.

NQKSF company, Be powerful and forever.

OIL SEAL FACTORY

Our 30 Years

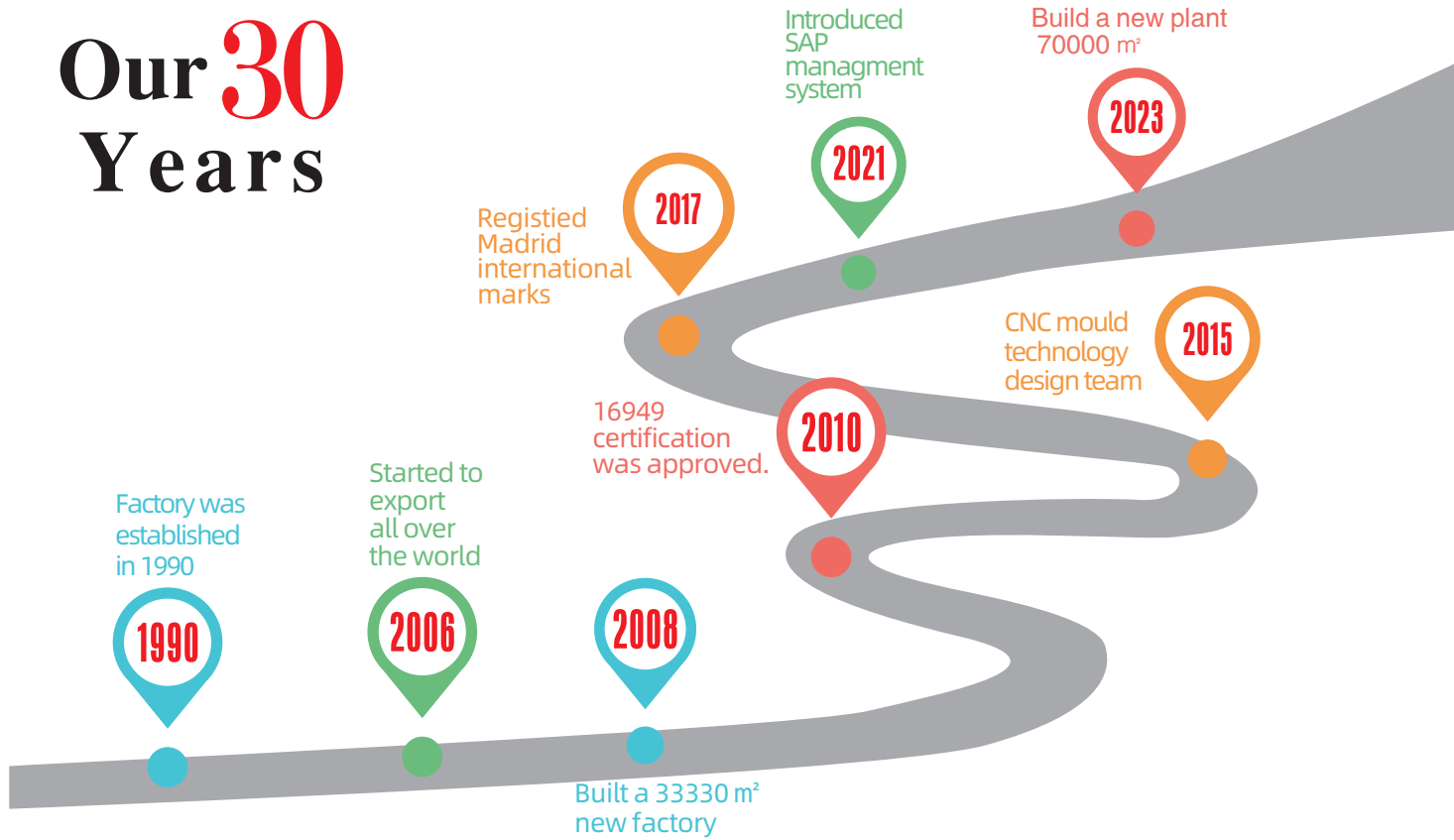

企业荣誉 Company honor





Trimming



Trimming



Trimming



Molding



Rubber mixing

OIL SEAL FACTORY

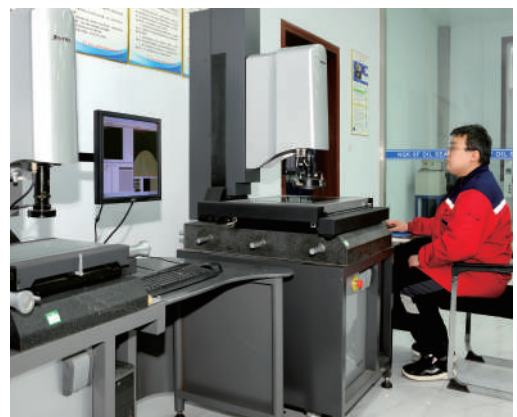

弹簧 金属骨架
SPRING & STEEL

弹簧与金属骨架的标准材料只限于使用介质润滑所用的油封。
弹簧与金属骨架的专用材料用于水及含有腐蚀性化学药液及气体所用的油封。
the normal material of spring and steel only work in the medium which is lubricating oil
Special materials of spring and steel work in the medium which contains water, corrosive chemicals and gases

弹簧的作用是提高密封唇在轴上的压紧力，是保持此压紧力所需部件，油封所使用的弹簧具有图所示特性。微小的伸长可以得到必要的负荷。在一定伸长限度下，弹簧负荷就没有太大变化。另外，在使用范围内油封的弹簧应能发挥功能，对设定长度考虑适当的伸长率。

The function of the spring is to increase the pressing force of the sealing lip on the shaft. The spring used in the oil seal has the characteristics shown in the picture. A slight stretch can get the necessary load. Within a certain elongation limit. The spring load does not change much. In addition, the spring should be able to play function within the range, and set to different lengths to account for proper elongation.

金属骨架的作用是保持油封与腔体孔间的配合力，更重要的作用是保持密封唇在确定的位置上。

The function of the steel is to maintain the matching force between the oil seal and the cavity hole and more importantly, to keep the sealing lip in a certain position.

备注：○ 优 × 差

Remarks: ○ Excellent × Poor

密封介质 Medium	弹 簧 SPRING		
	标准材料 Normal Material	专用材料 Special Material	
	高碳钢 (弹簧、钢丝) High-carbon steel wire	不锈钢丝 Stainless steel wire	
		304	316
润滑油 Lubricant	○	○	○
水 Water	×	○	○
水蒸气 Steam	×	○	○
海水 Seawater	×	×	○
酸 Acid	×	×	○
碱 Alkali	×	○	○

密封介质 Medium	金属骨架 STEEL		
	标准材料 Normal Material	专用材料 Special Material	
	碳钢板 Steel	不锈钢 Stainless steel	
	冷轧钢板 Cold rolled steel	304	316
润滑油 Lubricant	○	○	○
水 Water	×	○	○
水蒸气 Steam	×	○	○
海水 Seawater	×	×	○
酸 Acid	×	×	○
碱 Alkali	×	○	○

橡胶特性 Rubber Characteristics

项目 Performance 种类 Materials	耐油性 Oil Resistance	耐硬性 Hardness	耐酸性 Acid Resistance	耐水性 Water Resistance	耐候性 Weather Resistance	耐磨性 Wear Resistance	温度范围 Temperature		特 长 Characteristics
							最低温度 Low	最高温度 High	
丁腈橡胶(NBR)	◎	○	○	○	△	◎	-40	*120	耐矿物油，耐磨性好，在油封中使用的最多，但不能使用于酮类及脂类极性溶剂中。 Oil Resistance and wear Resistance both good, NBR is more popular material in oil seal. But it cannot be used in ketones and lipid polar solvents.
氢化丁腈橡胶(HNBR)	◎	○	○	○	○	◎	-50	*150	保持了丁腈橡胶的特性，耐热性，耐油性及耐候性比丁腈橡胶优良。 Keep the NBR Performance, Heat Resistance and weather Resistance better than the NBR
丙烯酸酯橡胶(ACM)	◎	×	△	△	◎	◎	-25	*150	保持了丁腈橡胶同样的耐油性，耐热性比硅橡胶稍差，但是耐候性优良，耐碱性与耐水性比丁腈橡胶和其他橡胶要差些 Oil Resistance is same with NBR, but weather Resistance is good, Acid Resistance and water Resistance is poor then NBR, heat Resistance is poor then VMQ
硅橡胶(VMQ)	○	×	△	△	◎	◎	-60	*225	兼有优良的耐热性，耐寒性与耐候性，但耐碱性与耐水性比其他橡胶差一些 Good heat resistance, cold resistance, weather resistance, but the Acid resistance and water resistance is poor then other material
氟橡胶(FKM)	◎	△	○	○	◎	◎	-20	*250	具有超过硅橡胶的耐热性，优良的耐油性和耐化学药品性相配合，在各种橡胶中是油封有橡胶性能平衡最优良的品种 Good heat resistance, cold resistance, weather resistance, but the Acid resistance and water resistance is poor then other material
乙烯-丙烯橡胶(EPDM)	×	○	○	◎	◎	○	-40	*125	耐水性，耐极性溶剂性，耐无机药品性及耐候性优良的油封橡胶但耐油性差。 Good Water resistance, Polar solvent resistance, weather resistance, chemicals resistance, but oil resistance is poor
聚四氟乙烯(PTFE)	◎	◎	◎	◎	◎	◎	-65	*260	耐热性，耐寒性，耐化学药品性，耐候性最优良，低摩擦系数的油封用材料差。 Good Heat resistance, cold resistance, weather resistance and chemicals resistance

备注：◎ 有耐性： ○ 除特定场合有耐性 △ 除特定场合外无耐性 × 无耐性
Remark: ◎ Excellent ○ Fair-to-good △ Fair × Poor

OIL SEAL FACTORY



O-型圈尺寸公差标准 O-ring Dimension Tolerance Standard

内径 ID	公差 (±)
—	1.50 0.10
1.51	14.00 0.12
1.01	25.00 0.00
25.01	30.00 0.25
30.01	38.00 0.30
38.01	42.00 0.33
42.01	48.00 0.38
48.01	57.00 0.41
57.01	64.00 0.45
64.01	73.00 0.50
73.01	89.00 0.60
89.01	102.00 0.68
102.01	105.00 0.71
105.01	125.00 0.76
125.01	153.00 0.88
153.01	178.00 1.01
178.01	203.00 1.14
203.01	230.00 1.27
230.01	267.00 1.39
267.01	330.00 1.52
330.01	381.00 1.65
381.01	394.00 1.77
394.01	418.00 1.90
418.01	431.00 2.03
431.01	470.00 2.15
470.01	533.00 2.28
533.01	558.02 2.54
558.01	583.00 2.66
583.01	610.00 2.78
610.01	634.00 2.92
—	2.00 0.07
2.01	3.00 0.08
3.01	4.00 0.10
4.01	5.00 0.12
5.01	7.00 0.15
7.01	10.00 0.20
10.01	15.00 0.25
15.01	25.00 0.35
25.01	100.00 0.45

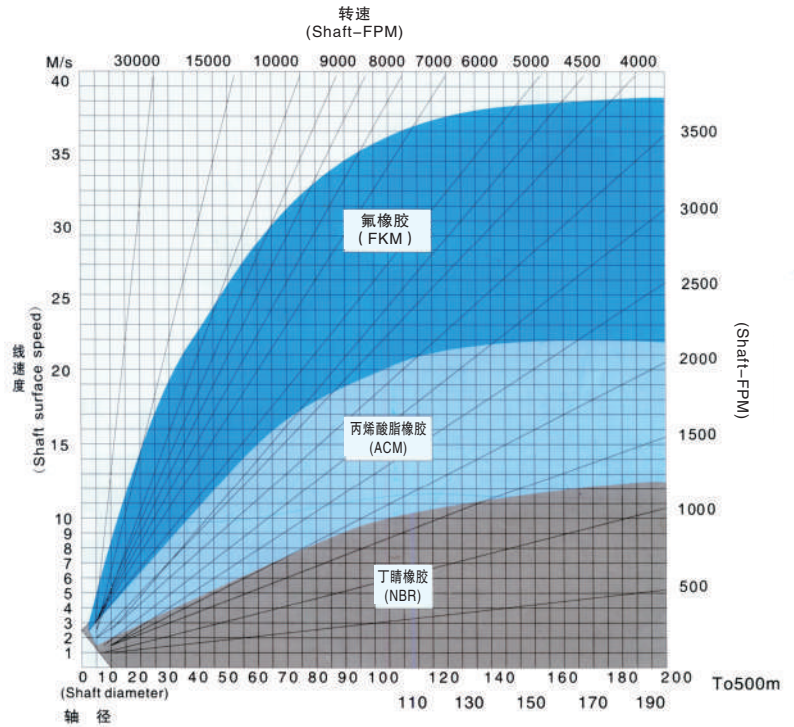

油封内径公差值 Oil Seal Inner Diameter Tolerance Value

轴径 Shaft Diameter	主唇口 primary lip		副唇口 secondary lip	
	过盈量interference fit	极限偏差limit deviations	过盈量interference fit	极限偏差limit deviations
5-30	0.7-1.0	+0.2 -0.3	0.3	±0.15
30-60	1.0-1.2	+0.2 -0.5	0.4	±0.20
60-80	1.2-1.4	+0.2 -0.6	0.5	±0.25
80-130	1.4-1.8	+0.2 -0.8	0.6	±0.30
130-250	1.8-2.4	+0.3 -0.9	0.7	±0.35
250-400	2.4-3.0	+0.4 -1.0	0.9	±0.40

油封外径公差值及配套轴孔公差值 Oil Seal Outer Diameter Tolerance Value – Matching Shaft Hole Tolerance Value

轴径与孔径 Shaft & Hole Diameter	配套孔径公差 Hole tolerances	配套轴径公差 Shaft tolerances	油封外径公差 oil seal Out Diameter tolerances	
			金属外壳 metal (outside)	包胶外壳 rubber (outside)
6.00-10.00	+0.020	-0.090	+0.07/+0.18	+0.12/+0.27
10.01-18.00	+0.027	-0.110	+0.07/+0.18	+0.12/+0.27
18.01-30.00	+0.033	-0.130	+0.08/+0.20	+0.15/+0.30
30.01-50.00	+0.039	-0.160	+0.08/+0.20	+0.15/+0.30
50.01-80.00	+0.046	-0.190	+0.09/+0.23	+0.17/+0.32
80.01-120.00	+0.054	-0.220	+0.10/+0.25	+0.20/+0.35
120.01-180.00	+0.063	-0.250	+0.11/+0.28	+0.22/+0.40
180.01-250.00	+0.072	-0.290	+0.13/+0.31	+0.25/+0.45
250.01-315.00	+0.081	-0.320	+0.15/+0.35	+0.28/+0.50
315.01-400.00	+0.089	-0.360	+0.18/+0.40	+0.30/+0.55
400.01-500.00	+0.097	-0.400	+0.20/+0.45	+0.33/+0.60

骨架油封正确安装与不正确安装对比图

COMPARISON CHART FOR CORRECT AND INCORRECT INSTALLATION

骨架油封的正确组装
CORRECT ASSEMBLING

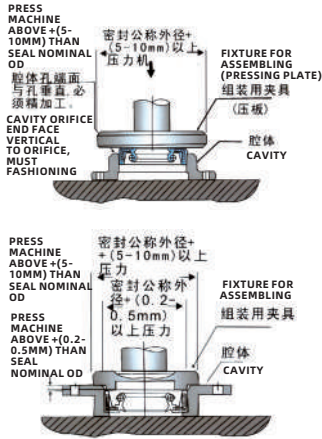

骨架油封不正确的组装
INCORRECT ASSEMBLING

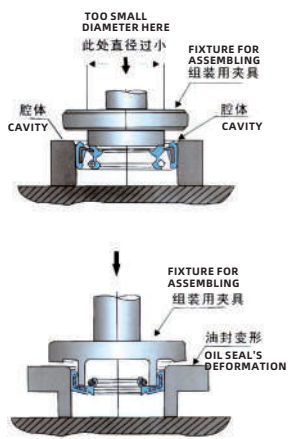

骨架油封的正确组装
CORRECT ASSEMBLING

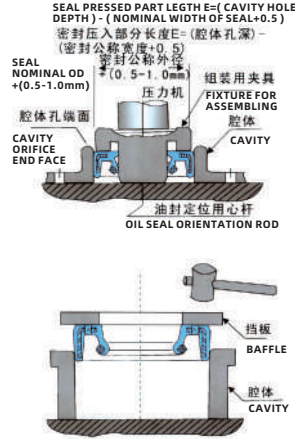

骨架油封不正确的组装
INCORRECT ASSEMBLING

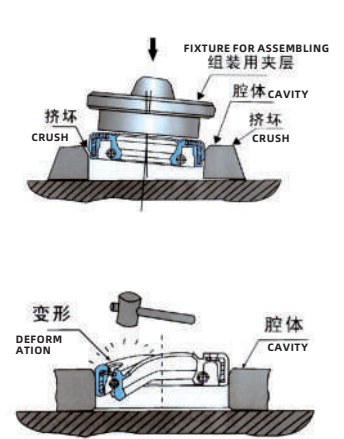

包装PACKAGE

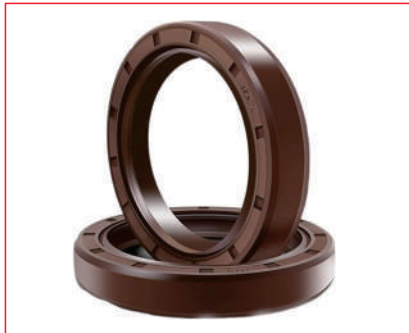

OIL SEAL FACTORY

USIT Ring 组合密封垫圈

PRODUCT INSTRUCTION

SUITABLE FOR PIPELINE SYSTEM WITH OIL AS MEDIUM, USED AS JOINT FOR WELDING PART, CUTTING FERRULE AND EXPANDING TUBE. SEAL IN PRESSURE SYSTEMS FOR PLUGS AND MECHANICAL DEVICES. TO PREVENT LEAKAGE OF OIL, FUEL, WATER, DRUG AND SO ON NOMINAL PRESSURE: TO 40 MPA OPERATING TEMPERATURE: -25℃ to 80℃.

产品说明:

适用于以油为介质的管路系统中, 供焊接, 卡套, 扩大管接头, 螺塞及机械装置的压力系统密封, 为防止油液, 燃料, 水和药品等泄露, 公称压力至40MPa工作温度为-25℃至80℃

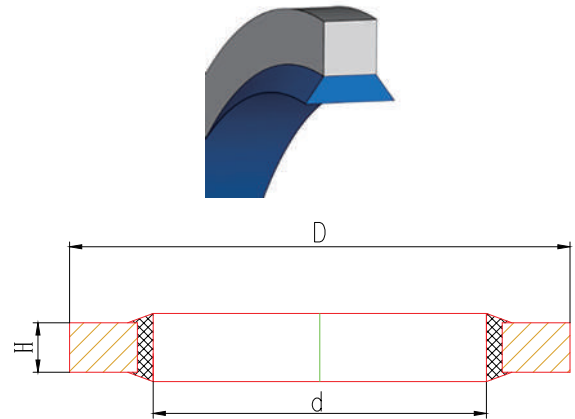
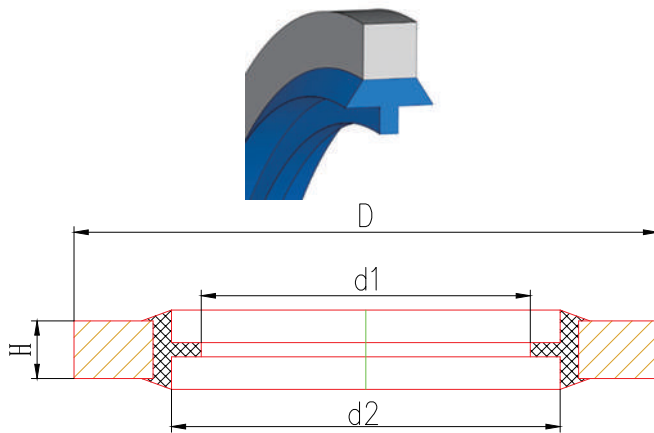

自定心镀锌 USIT-Ring I SF

规格	外径	大内径	小内径	厚度	价格RMB
SPECIFICATION	D	d2	d1	H	Price
M5	9	5.7	4.5	1	0.91
M6	11	6.7	5	1	0.91
M8	14	8.7	6.5	1	0.91
M10	16	10.7	8.5	1.5	1.04
M12	18	12.7	9.8	1.5	1.04
M14	22	14.7	11.5	1.5	1.17
M16	24	16.7	13.5	1.5	1.3
M18	26	18.7	15	1.5	1.43
M20	28	20.7	17	1.5	1.82
M22	29.7	22.7	19	2	2.21
M24	31.7	24.7	20	2	2.34
M26	34.7	26.7	22.5	2	2.47
M27	34.7	27.7	23	2	2.6
M30	37.7	30.7	27	2	2.73
M33	41.7	33.7	30	2	2.86
M36	45.7	36.7	33	2	3.25
M39	49.7	39.7	34	2	3.64
M42	52.7	42.7	39	2	3.9
M45	55.7	45.7	40	2	4.16
M48	59.7	48.7	42	2	4.55
M54	67.7	54.7	47	2	4.94
M60	74.7	60.7	53	2	5.2
1/8	15.88	10.37	8.56	2	1.3
1/4	20.57	13.74	11.45	2	1.43
3/8	23.80	17.20	14.96	2	1.56
1/2	28.58	21.54	18.64	2	2.08
1/2	28.58	21.54	18.64	2.5	2.34
3/4	34.93	27.05	24.13	2	2.99
3/4	34.93	27.05	24.13	2.5	3.25
5/8	31.25	23.49	20.60	2.5	3.64
7/8	38.10	30.81	27.89	2.5	3.9
1"	42.80	33.89	30.30	2.5	4.68
1 1/4	52.38	42.93	38.96	2.5	5.46
1 1/2	58.60	48.44	43.86	2.5	6.63
2"	73.00	60.58	56.67	2.5	9.1
2 1/2	90.17	76.08	72.20	2.5	11.7
1 3/4	69.58	54.89	50.80	2	9.1

JB982-77国标 B型 USIT-Ring I

规格	外径	内径	壳厚度	价格RMB
SPECIFICATION	D	d	H	Price
φ6	11.8	6.2	2	0.650
φ8	13.8	8.2	2	0.650
φ10	15.8	10.2	2	0.650
φ12	17.8	12.2	2	0.650
φ14	19.8	14.2	2	0.780
φ16	21.8	16.2	2	0.910
φ18	24.8	18.2	2	1.040
φ20	27.8	20.2	2	1.170
φ22	29.8	22.2	2	1.300
φ24	31.7	24.2	2	1.430
φ27	34.7	27.3	2	1.560
φ30	37.7	30.3	2	1.950
φ33	41.7	33.3	2	2.080
φ36	45.7	36.3	2	2.730
φ39	49.7	39.3	2	2.990
φ42	52.7	42.3	2	3.380
φ45	55.7	45.3	2	3.640
φ48	59.7	48.3	2	3.770
φ52	65.7	52.3	2	4.290
φ60	74.7	60.3	2	4.940

现货油封 OIL SEAL IN STOCK

TC型

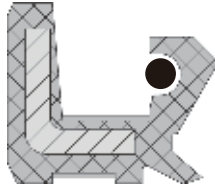

TC型：双唇（一个主唇口，一个副唇口），一根弹簧，钢骨架被橡胶全部包裹，旋转密封，用在压力低，一方有密封介质，另一方有轻微灰尘场合，最高压力0.03mpa(0.3kgf/cm2)

TC TYPE : DOUBLE LIPS (A MAIN LIP, A VICE LIP), ONE SPRING, STEEL FRAME WRAPPED IN RUBBER, ROTATING SEAL, USED IN THE OCCASION OF LOW PRESSURE WITH ONE SEALED MEDIUM AND ANOTHER LITTLE DUST, HIGHEST PRESSURE 0.03mpa(0.3kgf/cm2).

序号	类型	规格	丁腈橡胶单价RMB	氟橡胶单价RMB
NO.	TYPE	SPECIFICATION	NBR PRICE	FKM PRICE
1	TC	3*9*3	5	13.5
2	TC	3.18*10*3.5	5	13.5
3	TC	3.5*9*3	5	13.5
4	TC	3.5*16.5*7	5.2	13.5
5	TC	4*9*3	5	13.5
6	TC	4*12*4	4.7	12
7	TC	4*12*5	4.5	12
8	TC	4*12*6	4.7	12
9	TC	4*14*5	4.7	12
10	TC	4*16*6	5	12.5
11	TC	4*16*7	5	12.5
12	TC	4*17*7	4.9	12.5
13	TC	4*18*7	4.8	12.5
14	TC	4.5*15*5	4.5	12.5
15	TC	4.5*16*4	5	12.5
16	TC	4.5*16*7	5	12.5
17	TC	4.5*17*7	5	12.5
18	TC	4.5*18*7	4.8	12.5
19	TC	4.8*9*2.7	5	12.5
20	TC	4.8*17*7	5	12.5
21	TC	4.8*22*7	5.1	15
22	TC	4.8*25*5.5	5.1	15
23	TC	5*10*4	4.5	12
24	TC	5*11*4	5.5	12
25	TC	5*12*5	4.5	12
26	TC	5*12*8	4.5	13.5
27	TC	5*14*5	4.5	12
28	TC	5*15*5	4.5	12.5
29	TC	5*15*6	4.7	12.5
30	TC	5*16*6	4.7	12.5
31	TC	5*16*7	4.8	12.5
32	TC	5*16*8	4.8	12.5
33	TC	5*17*6	4.8	12.5
34	TC	5*17*7	4.8	12.5
35	TC	5*18*6	4.5	12.5
36	TC	5*18*7	4.8	12.5
37	TC	5*19*7	4.9	13
38	TC	5*20*3	4.9	14.5
39	TC	5*22*7	6	14.5
40	TC	5*25*5	5.5	15
41	TC	5.2*14*4	4.5	15
42	TC	5.5*11*3	6.5	13.5
43	TC	5.5*14*5.7	4.5	15
44	TC	5.5*16*8	4.5	12.5
45	TC	6*11*2	7.5	12.5
46	TC	6*11*4	8.5	12.5
47	TC	6*12*4	4.5	12.5
48	TC	6*12*5	4.7	12.5
49	TC	6*12*8	4.5	13.5
50	TC	6*13*4.5	4.7	12.5
51	TC	6*13*8	4.5	13.5
52	TC	6*14*3	4.5	13.5
53	TC	6*14*4	4.5	13.5
54	TC	6*14*6	4.5	13.5
55	TC	6*15*4	4.5	13.5

序号	类型	规格	丁腈橡胶单价RMB	氟橡胶单价RMB
NO.	TYPE	SPECIFICATION	NBR PRICE	FKM PRICE
56	TC	6*15*7	4.7	13.5
57	TC	6*16*5	4.5	12.5
58	TC	6*16*6	4.5	12.5
59	TC	6*16*7	4.8	12.5
60	TC	6*17*7	4.8	12.5
61	TC	6*17.5*8	5	12.5
62	TC	6*18*6	4.8	12.5
63	TC	6*18*7	4.8	12.5
64	TC	6*19*6	4.8	13
65	TC	6*19*7	4.9	12.5
66	TC	6*20*5.5	5.5	12.5
67	TC	6*22*5	5	14
68	TC	6*22*7	5.1	14.5
69	TC	6*22*8	5.3	16
70	TC	6*25*6	5	15
71	TC	6*25*8	5.3	16
72	TC	6*26*6	5.4	16
73	TC	6*26*7	5.4	16
74	TC	6*30*7	6	18
75	TC	6*34*5.5	6.5	18.5
76	TC	6*34*7	6.5	21
77	TC	6*35*7	7.5	23
78	TC	6.2*16*5	4.5	12.5
79	TC	6.3*13*8	4.7	13.5
80	TC	6.3*15*8	5	15
81	TC	6.5*10*2.8	5	15
82	TC	6.5*12*4	9.5	15
83	TC	6.5*14*5.7	4.5	15
84	TC	6.5*14.5*7	4.5	15
85	TC	6.80*22*7	4.6	14.5
86	TC	7*13*3	4.5	12.5
87	TC	7*13*4	4.5	12.5
88	TC	7*14*3.5	4.5	12.5
89	TC	7*14*4	4.5	12.5
90	TC	7*15*2.5	4.8	12.5
91	TC	7*15*5	4.5	12.5
92	TC	7*16*5	4.6	12.5
93	TC	7*16*7	4.5	12.5
94	TC	7*17*4	4.5	12.5
95	TC	7*17*5	4.5	12.5
96	TC	7*17*7	4.8	12.5
97	TC	7*18*4.5	4.8	12.5
98	TC	7*18*5	4.8	12.5
99	TC	7*18*6	4.8	12.5
100	TC	7*18*7	4.8	12.5
101	TC	7*18*8	5	13
102	TC	7*19*5	4.7	12.5
103	TC	7*19*7	4.9	13
104	TC	7*20*7	5	12.5
105	TC	7*22*5.4	4.8	14
106	TC	7*22*6	5	14
107	TC	7*22*7	4.6	14.5
108	TC	7*22*8	5	16
109	TC	7*24*5	4.9	14.5
110	TC	7*26.2*5.5	5	15.5
111	TC	7*31*7	5.5	18
112	TC	7.5*30*10	5.5	18
113	TC	8*12*2	10.5	12.5
114	TC	8*12*3	4.5	12.5
115	TC	8*13*5	4.5	12.5
116	TC	8*14*3	4.5	12.5
117	TC	8*14*4	4.5	12.5
118	TC	8*14*5	4.5	12.5
119	TC	8*14*6	4.5	12.5
120	TC	8*14*7	4.5	12.5
121	TC	8*15*4	4.5	12.5
122	TC	8*15*4.5	4.5	12.5
123	TC	8*15*5	4.5	12.5
124	TC	8*15*6	4.7	12.5
125	TC	8*15*7	4.7	12.5
126	TC	8*15*8	4.7	13.5
127	TC	8*16*4	4.5	12.5

现货油封 OIL SEAL IN STOCK

序号	类型	规格	丁腈橡胶单价RMB	氟橡胶单价RMB
NO.	TYPE	SPECIFICATION	NBR PRICE	FKM PRICE
128	TC	8*16*5	4.5	12.5
129	TC	8*16*5.5	5	12.5
130	TC	8*16*6	4.5	12.5
131	TC	8*16*6.5	5	12.5
132	TC	8*16*7	4.5	12.5
133	TC	8*16*8	4.7	12.5
134	TC	8*17*3.5	5	12.5
135	TC	8*17*4	4.6	12.5
136	TC	8*17*5	4.6	12.5
137	TC	8*17*7	4.8	12.5
138	TC	8*18*3.5	4.8	12.5
139	TC	8*18*4	4.5	12.5
140	TC	8*18*5	4.5	12.5
141	TC	8*18*6	4.8	12.5
142	TC	8*18*7	5	13
143	TC	8*18*8	5	13
144	TC	8*18*10	6	15
145	TC	8*19*5	4.5	12.5
146	TC	8*19*6.3	4.9	12.5
147	TC	8*19*7	4.5	12.5
148	TC	8*20*4.2	5	12.5
149	TC	8*20*5	4.7	12.5
150	TC	8*20*7	4.9	12.5
151	TC	8*20*8	5	12.5
152	TC	8*21*6	4.9	13
153	TC	8*21.5*10	7	16
154	TC	8*22*4	4.6	14
155	TC	8*22*5	4.6	14
156	TC	8*22*6	4.7	14
157	TC	8*22*7	4.7	14.5
158	TC	8*22*8	4.8	16
159	TC	8*22*10	5	17
160	TC	8*23*5	5	14.5
161	TC	8*23*7	5.2	14.5
162	TC	8*24*7	5.2	14.5
163	TC	8*25*7	5.3	15
164	TC	8*25*8	5.3	16
165	TC	8*25*9	5.4	18
166	TC	8*26*4	5	15.5
167	TC	8*26*6	5.3	15.5
168	TC	8*26*7	5.3	16
169	TC	8*28*5	5.1	16
170	TC	8*28*7	5.4	16
171	TC	8*30*6	5	18
172	TC	8*30*7	5.5	18
173	TC	8*34*8	6.5	21
174	TC	9*15*5	4.7	13.5
175	TC	9*15*7	4.7	13.5
176	TC	9*15.1*4	4.7	13.5
177	TC	9*16*3.2	4.5	13.5
178	TC	9*16*5	4.7	13.5
179	TC	9*16*7	4.7	13.5
180	TC	9*17*4	4.5	12.5
181	TC	9*17*6	4.8	12.5
182	TC	9*17.5*7.6	5	13.5
183	TC	9*18*4	4.7	12.5
184	TC	9*18*7	4.7	12.5
185	TC	9*19*5	4.5	12.5
186	TC	9*19*7	4.8	12.5
187	TC	9*20*5	4.8	13.5
188	TC	9*20*6	4.8	12.5
189	TC	9*20*7	5	12.5
190	TC	9*21*5	4.9	13
191	TC	9*22*7	4.7	14.5
192	TC	9*23*5	4.8	14.5
193	TC	9*24*6	5.2	14.5
194	TC	9*24*7	5.2	14.5
195	TC	9*25*7	5.1	15
196	TC	9*26*6	5.2	15.5
197	TC	9*26*7	5.2	16
198	TC	9*29*7	5.3	16
199	TC	9*30*7	5.5	18

序号	类型	规格	丁腈橡胶单价RMB	氟橡胶单价RMB
NO.	TYPE	SPECIFICATION	NBR PRICE	FKM PRICE
200	TC	9.2*17.5*8	5	12.5
201	TC	9.5*16*4	4.7	12.5
202	TC	9.5*16*7	5	12.5
203	TC	9.5*19.05*7	5	13
204	TC	9.5*19.1*7	5	13
205	TC	9.6*17.5*7	5	12.5
206	TC	10*14*3	4.5	12.5
207	TC	10*15*4	4.5	13.5
208	TC	10*15*7	4.5	13.5
209	TC	10*16*3	4.8	12.5
210	TC	10*16*4	4.5	12.5
211	TC	10*16*5	4.5	12.5
212	TC	10*16*7	4.5	12.5
213	TC	10*16*3/4.5	5	12.5
214	TC	10*17*3	5	12.5
215	TC	10*17*4	4.5	12.5
216	TC	10*17*5	4.5	12.5
217	TC	10*17*6	4.6	12.5
218	TC	10*17*7	4.6	12.5
219	TC	10*17.5*7	5	12.5
220	TC	10*18*4	4.5	12.5
221	TC	10*18*5	4.5	12.5
222	TC	10*18*6	4.5	12.5
223	TC	10*18*7	4.5	12.5
224	TC	10*18*8	4.8	12.5
225	TC	10*19*4	4.5	12.5
226	TC	10*19*4.5	4.5	12.5
227	TC	10*19*5	4.6	12.5
228	TC	10*19*6	4.8	12.5
229	TC	10*19*6.5	4.8	14.2
230	TC	10*19*7	4.5	12.5
231	TC	10*19*10	5	15
232	TC	10*20*4	4.5	12.5
233	TC	10*20*4.5	5	12.5
234	TC	10*20*5	4.5	12.5
235	TC	10*20*6	5	12.5
236	TC	10*20*7	4.6	12.5
237	TC	10*20*9	4.6	12.5
238	TC	10*20*9.5	7	12.5
239	TC	10*20.1*5	7	12.5
240	TC	10*21*4	4.8	13
241	TC	10*21*4.5	4.8	13
242	TC	10*21*5	4.7	13
243	TC	10*21*6	4.9	13
244	TC	10*21*7	4.9	13.5
245	TC	10*21*10.5	7	16
246	TC	10*22*4	4.5	14
247	TC	10*22*5	4.5	14
248	TC	10*22*6	4.5	14
249	TC	10*22*7	4.7	14.5
250	TC	10*22*7.3	5	14.5
251	TC	10*22*8	5	16
252	TC	10*22*10	5	17
253	TC	10*23*5	5	14.5
254	TC	10*23*7	5	14.5
255	TC	10*23*8	5.2	15
256	TC	10*23*9	5.3	15.5
257	TC	10*23.5*7	5	15
258	TC	10*24*4	5	14.5
259	TC	10*24*4.5	5	14.5
260	TC	10*24*5	5	14.5
261	TC	10*24*6	5	14.5
262	TC	10*24*7	5.2	14.5
263	TC	10*24*8	5.2	15
264	TC	10*25*5	4.5	15
265	TC	10*25*7	4.8	15
266	TC	10*25*8	5.4	16
267	TC	10*25*10	5.5	21
268	TC	10*26*4	5	15.5
269	TC	10*26*5	5	15.5
270	TC	10*26*6	5	15.5
271	TC	10*26*7	4.9	16

现货油封 OIL SEAL IN STOCK

序号	类型	规格	丁腈橡胶单价RMB	氟橡胶单价RMB
NO.	TYPE	SPECIFICATION	NBR PRICE	FKM PRICE
272	TC	10*26*8	5.3	16.5
273	TC	10*27*6	5.1	15.5
274	TC	10*27*7	5.1	15.5
275	TC	10*28*7	5.5	16
276	TC	10*28*10	5.6	20
277	TC	10*28*13.4	6	23
278	TC	10*29*7	5.5	16
279	TC	10*30*7	5.5	18
280	TC	10*30*8	5	18
281	TC	10*30*10	6	18
282	TC	10*30*12	6	18
283	TC	10*31*7	5.5	18
284	TC	10*31*13.5	6.6	21
285	TC	10*32*7	5.6	18
286	TC	10*32*10	6.5	22
287	TC	10*34*7	6.5	21
288	TC	10*35*4	7	22
289	TC	10*35*8	7.5	22
290	TC	10*45*5	8	27
291	TC	10.5*15*3	4.5	13.5
292	TC	10.5*15*3/2.76	5	13.5
293	TC	10.5*34*7	6.5	21
294	TC	10.8*20*9	7	12.5
295	TC	11*16*3.2	4.5	12.5
296	TC	11*16*5	4.7	12.5
297	TC	11*17*4	4.6	12.5
298	TC	11*17*4.5	4.5	12.5
299	TC	11*17*5	4.5	12.5
300	TC	11*17.2*4	4.6	12.5
301	TC	11*17.65*5/6.5	6	12.5
302	TC	11*18*4	4.5	12.5
303	TC	11*18*5	4.5	12.5
304	TC	11*19*4.5	4.7	12.5
305	TC	11*19*5	4.7	12.5
306	TC	11*19*6	4.7	12.5
307	TC	11*19*7	4.8	12.5
308	TC	11*20*4	4.6	12.5
309	TC	11*20*7	4.7	12.5
310	TC	11*21*7	5.1	13.5
311	TC	11*22*6	5.1	14.5
312	TC	11*22*7	5.1	14.5
313	TC	11*22*8	5.1	16
314	TC	11*23*7	5	15.5
315	TC	11*23*8	5.2	15.5
316	TC	11*24*6	5.1	14.5
317	TC	11*24*7	5.1	15
318	TC	11*25*7	5	15
319	TC	11*25*9	5.3	18
320	TC	11*26*4	5	15.5
321	TC	11*26*7	5.2	16
322	TC	11*28*7	5.4	17
323	TC	11*29*7	5.5	16
324	TC	11*30*5	6	18
325	TC	11*30*7	6	18
326	TC	11*30*10	6	21
327	TC	11.1*25.4*6.35	7	16
328	TC	11.6*24*5	6	14.5
329	TC	11.6*24*10	6	20
330	TC	11.90*24*6	6	14.5
331	TC	12*16*3	4.5	12.5
332	TC	12*17*2.5	4.5	12.5
333	TC	12*18*3	4.5	12.5
334	TC	12*18*4	4.5	12.5
335	TC	12*18*4.5	4.5	12.5
336	TC	12*18*5	4.5	12.5
337	TC	12*18*5.5	4.5	12.5
338	TC	12*18*6	4.5	12.5
339	TC	12*18.5*3	4.5	12.5
340	TC	12*19*3	4.7	12.5
341	TC	12*19*4	4.8	12.5
342	TC	12*19*5	4.7	12.5
343	TC	12*19*7	4.8	12.5

序号	类型	规格	丁腈橡胶单价RMB	氟橡胶单价RMB
NO.	TYPE	SPECIFICATION	NBR PRICE	FKM PRICE
344	TC	12*19*8	5	13
345	TC	12*20*4	4.7	12.5
346	TC	12*20*5	4.5	12.5
347	TC	12*20*5.5	4.7	12.5
348	TC	12*20*6	4.6	12.5
349	TC	12*20*7	4.6	14
350	TC	12*21*4	4.6	13
351	TC	12*21*5	4.7	13
352	TC	12*21*7	4.6	13.5
353	TC	12*21*7.5	5	13.5
354	TC	12*21.5*5	4.9	13
355	TC	12*21.5*6	4.9	13
356	TC	12*21.5*7	4.9	13.5
357	TC	12*22*4	4.6	14
358	TC	12*22*4.5	4.8	14
359	TC	12*22*5	4.6	14
360	TC	12*22*5.5	4.8	14
361	TC	12*22*6	4.6	14
362	TC	12*22*7	4.5	14.5
363	TC	12*22*8	5	16
364	TC	12*22*9	4.7	17
365	TC	12*22*10	5.3	17.5
366	TC	12*22.5*5	4.9	14
367	TC	12*23*7	5	14.5
368	TC	12*23*8	5.2	15.5
369	TC	12*23*10	6	17
370	TC	12*23.5*7	5	15
371	TC	12*24*4	5	14.5
372	TC	12*24*4.5	5	14.5
373	TC	12*24*5	5	14.5
374	TC	12*24*5.5	5	14.5
375	TC	12*24*6	5	14.5
376	TC	12*24*7	4.7	14.5
377	TC	12*24*8	5.2	14.5
378	TC	12*25*4.5	5	15
379	TC	12*25*5	5	15
380	TC	12*25*6	5	15
381	TC	12*25*7	4.8	15
382	TC	12*25*8	5	16
383	TC	12*25*10	5.1	21
384	TC	12*25.5*7	7	16
385	TC	12*26*4	5	15.5
386	TC	12*26*5	5	15.5
387	TC	12*26*6	5	16
388	TC	12*26*7	5	16
389	TC	12*26*8	5.5	16.5
390	TC	12*27*7	5.3	16
391	TC	12*28*5	5	16
392	TC	12*28*5.5	5.4	16
393	TC	12*28*6	5.2	16
394	TC	12*28*7	5.1	16
395	TC	12*28*8	5.5	16
396	TC	12*28.5*5	5.2	16
397	TC	12*28.5*7	5.5	16
398	TC	12*29*7	5.1	16
399	TC	12*30*6	5.1	18
400	TC	12*30*7	5.1	18
401	TC	12*30*8	5.8	18
402	TC	12*30*9	5.9	18
403	TC	12*30*10	5.9	18
404	TC	12*32*5	5.5	18
405	TC	12*32*5.5	5.5	18
406	TC	12*32*6.5	5.5	18
407	TC	12*32*7	5.5	18
408	TC	12*32*10	6.5	22
409	TC	12*34*7	6.5	21
410	TC	12*35*6	7	19.5
411	TC	12*35*7	6	21
412	TC	12*35*10	7.5	22
413	TC	12*37*7	7	20
414	TC	12*45*7	8	27
415	TC	12.5*19*4	4.8	13.5

现货油封 OIL SEAL IN STOCK

序号	类型	规格	丁腈橡胶单价RMB	氟橡胶单价RMB
NO.	TYPE	SPECIFICATION	NBR PRICE	FKM PRICE
416	TC	12.5*21*7	7	13.5
417	TC	12.5*22.5*5	4.9	14
418	TC	12.5*22.5*6	5	14
419	TC	12.5*28*5	5.4	16
420	TC	12.5*32*15	8	25
421	TC	12.5*34*10	8	23
422	TC	12.5*38*10	7	26
423	TC	12.7*22.6*5	5	14
424	TC	12.7*23*5	5	17
425	TC	12.7*25.4*4.83	5	16
426	TC	12.7*25.4*9.5	7	20
427	TC	12.7*28*6.7	5.4	16
428	TC	12.7*28.57*6.3	5.5	16
429	TC	13*19*3.5	5.2	13.5
430	TC	13*19*7	4.9	13.5
431	TC	13*20*4	4.7	12.5
432	TC	13*20*5	4.8	12.5
433	TC	13*20*7	4.9	14
434	TC	13*22*4	4.8	14
435	TC	13*22*5	4.6	14
436	TC	13*22*5.5	5	14
437	TC	13*22*7	4.7	14.5
438	TC	13*23*5	5	14.5
439	TC	13*23*7	5.1	14.5
440	TC	13*24*5	4.9	14.5
441	TC	13*24*6	5	14.5
442	TC	13*24*6.5	5	14.5
443	TC	13*24*7	5	14.5
444	TC	13*25*5	5.1	15
445	TC	13*25*6	5.1	15
446	TC	13*25*7	5.1	15
447	TC	13*25*8.5	5.3	16
448	TC	13*26*5	5.1	15.5
449	TC	13*26*7	5.3	16
450	TC	13*26*9	5.5	16.5
451	TC	13*27*7	5.1	16
452	TC	13*28*7	5.6	16
453	TC	13*28*8	5.6	17
454	TC	13*28*10	5.7	20
455	TC	13*29*9	5.6	19
456	TC	13*30*7	5.5	18
457	TC	13*30*8	5.2	18
458	TC	13*32*7	5.7	18
459	TC	13*35*7	7.5	19.5
460	TC	13.7*24*5	4.5	14.5
461	TC	13.8*24*5	5	14.5
462	TC	14*20*3	4.7	12.5
463	TC	14*20*4	4.7	12.5
464	TC	14*20*4.5	4.7	12.5
465	TC	14*20*5	4.7	12.5
466	TC	14*20*6	4.8	12.5
467	TC	14*20*7	4.8	12.5
468	TC	14*21*4	4.8	13
469	TC	14*21*7	4.9	13.5
470	TC	14*22*4	4.6	14
471	TC	14*22*5	4.5	14
472	TC	14*22*5.2	4.8	14
473	TC	14*22*5.5	4.8	14
474	TC	14*22*6	4.7	14.5
475	TC	14*22*7	4.7	14.5
476	TC	14*22*6/7.3	5	15
477	TC	14*22.6*5	5	14
478	TC	14*23*5	5.5	14.5
479	TC	14*23*6	5	14.5
480	TC	14*23*7	5.1	15
481	TC	14*23*8	5.1	15
482	TC	14*24*4	4.7	14.5
483	TC	14*24*5	4.5	14.5
484	TC	14*24*6	4.9	14.5
485	TC	14*24*7	4.7	14.5
486	TC	14*25*4	5	15
487	TC	14*25*5	5	15

序号	类型	规格	丁腈橡胶单价RMB	氟橡胶单价RMB
NO.	TYPE	SPECIFICATION	NBR PRICE	FKM PRICE
488	TC	14*25*6	5.2	15
489	TC	14*25*7	5	15
490	TC	14*25*9	5.3	16
491	TC	14*25.5*7	5.3	16
492	TC	14*26*6	5.2	15.5
493	TC	14*26*7	5.2	16
494	TC	14*27*6	5.3	15.5
495	TC	14*27*7	5.3	16
496	TC	14*27*9	5.6	19
497	TC	14*28*6	5	16
498	TC	14*28*7	5.1	16
499	TC	14*28*8	5.4	17
500	TC	14*28*10	5.7	20
501	TC	14*29*7	5.4	16
502	TC	14*29*10	5.7	20
503	TC	14*30*5	5.2	18
504	TC	14*30*7	5.5	18
505	TC	14*30*8	5.7	18
506	TC	14*30*9	5.8	18
507	TC	14*30*10	5.4	20
508	TC	14*31*7	5.7	18.5
509	TC	14*32*7	5.7	18
510	TC	14*32*8	5.7	18
511	TC	14*32*10	6.5	22
512	TC	14*33*6	6	18.5
513	TC	14*34*7	6.5	18.5
514	TC	14*35*7	7.5	19.5
515	TC	14*35*8	6.1	21
516	TC	14*35*10	6.3	25
517	TC	14*36*7	7	20
518	TC	14*40*7	8	23
519	TC	14*40*10	8	25
520	TC	14*42*7	8	24
521	TC	14.5*25.5*7	5.2	16
522	TC	14.8*30*5	5.5	18
523	TC	14.8*30*7	5.5	18
524	TC	14.8*30*7.5	5.5	18
525	TC	14.8*32*7.5	6	18
526	TC	15*20*3.5	6	12.5
527	TC	15*21*3	4.8	13
528	TC	15*21*4	4.8	13
529	TC	15*21*5	4.8	13
530	TC	15*21*7	4.9	14
531	TC	15*22*3	4.6	14
532	TC	15*22*4	4.9	14
533	TC	15*22*5	4.5	14
534	TC	15*22*6	5	14
535	TC	15*22*7	5	14.5
536	TC	15*23*3	5.1	14.5
537	TC	15*23*4	4.9	14.5
538	TC	15*23*5	5	14.5
539	TC	15*23*7	5.1	15
540	TC	15*24*4	5	14.5
541	TC	15*24*4.5	5	14.5
542	TC	15*24*5	4.7	14.5
543	TC	15*24*6	5.1	14.5
544	TC	15*24*7	4.7	14.5
545	TC	15*25*4	5	15
546	TC	15*25*5	4.6	15
547	TC	15*25*6	5	15
548	TC	15*25*7	4.8	15
549	TC	15*25*8	5.3	16
550	TC	15*25*10	5.5	21
551	TC	15*25.5*7	5.2	16
552	TC	15*26*4	5	15.5
553	TC	15*26*5	5.1	15.5
554	TC	15*26*5.5	5.1	15.5
555	TC	15*26*6	5	15.5
556	TC	15*26*6.5	5.1	15.5
557	TC	15*26*7	5	16
558	TC	15*27*5	5.1	15.5
559	TC	15*27*6	5.3	15.5

现货油封 OIL SEAL IN STOCK

序号	类型	规格	丁腈橡胶单价RMB	氟橡胶单价RMB
NO.	TYPE	SPECIFICATION	NBR PRICE	FKM PRICE
560	TC	15*27*7	5.2	16
561	TC	15*27*8	5.3	17
562	TC	15*28*4	5.1	16
563	TC	15*28*4.5	5.1	16
564	TC	15*28*5	5	16
565	TC	15*28*6	5	16
566	TC	15*28*7	5	16
567	TC	15*28*8	5.5	16
568	TC	15*28*9	5.5	17
569	TC	15*28*10	5.6	20
570	TC	15*29*7	5.4	16
571	TC	15*29*10	5.7	20
572	TC	15*29.6*4	5.2	18
573	TC	15*30*4	5.2	18
574	TC	15*30*4.5	5.2	18
575	TC	15*30*5	5	18
576	TC	15*30*6	5.4	18
577	TC	15*30*7	5.1	18
578	TC	15*30*8	5.6	18
579	TC	15*30*10	5.5	20
580	TC	15*30*7/5	5.5	18
581	TC	15*31*7	5.6	18.5
582	TC	15*32*5	5.5	18
583	TC	15*32*7	5.5	18
584	TC	15*32*7.5	5.7	18
585	TC	15*32*8	6	20
586	TC	15*32*9	6	20
587	TC	15*32*10	6.5	21
588	TC	15*33*7	6	19.5
589	TC	15*33*9	6.1	22
590	TC	15*34*7	6.5	18.5
591	TC	15*35*4.5	7	19.5
592	TC	15*35*5	7	19.5
593	TC	15*35*5.3	7	19.5
594	TC	15*35*6	7	19.5
595	TC	15*35*7	6	19.5
596	TC	15*35*7.5	6.2	21
597	TC	15*35*8	6.2	21
598	TC	15*35*10	7	23
599	TC	15*35.1*10	7	23
600	TC	15*36*7	7	20
601	TC	15*37*7	7	20
602	TC	15*38*7	7	21
603	TC	15*38*10	7.5	25
604	TC	15*40*7	8	23
605	TC	15*40*8	8	23
606	TC	15*40*9	8	25
607	TC	15*40*10	7.5	25
608	TC	15*42*7	7.5	24
609	TC	15*42*8	8	24
610	TC	15*42*10	8	28
611	TC	15*47*7	8.5	29
612	TC	15*48*8	9	30
613	TC	15.5*25.5*7	5.5	16
614	TC	15.6*25.5*7	5.5	15.5
615	TC	15.76*22*4.5	4.7	14
616	TC	15.8*24*5	4.9	14.5
617	TC	15.8*25.4*6.3	7	16
618	TC	15.8*28.5*6.3	5.4	16
619	TC	15.8*28.5*7.9	5.5	16
620	TC	15.81*31.75*9.52	6	21
621	TC	15.87*28.57*9.52	6	20
622	TC	15.875*28.575*6.35	5.5	18.9
623	TC	15.88*28.55*6.35	5.5	18.9
624	TC	15.9*28.5*7	5.5	18.9
625	TC	16*21*6	4.9	13
626	TC	16*22*3	4.5	14
627	TC	16*22*3.2	4.9	14
628	TC	16*22*4	4.5	14
629	TC	16*22*5	4.7	14
630	TC	16*22*6	4.7	14
631	TC	16*22*7	4.9	14.5

序号	类型	规格	丁腈橡胶单价RMB	氟橡胶单价RMB
NO.	TYPE	SPECIFICATION	NBR PRICE	FKM PRICE
632	TC	16*22.75*4	5	14
633	TC	16*22.75*4.5	5	14
634	TC	16*23*3.3	4.9	14.5
635	TC	16*23*4	4.9	14.5
636	TC	16*23*5	5	14.5
637	TC	16*24*3	4.6	14.5
638	TC	16*24*4	4.6	14.5
639	TC	16*24*4.5	4.6	14.5
640	TC	16*24*5	4.6	14.5
641	TC	16*24*6	5.1	14.5
642	TC	16*24*7	4.7	14.5
643	TC	16*25*3	5.1	15
644	TC	16*25*4	5	15
645	TC	16*25*5	5.1	15
646	TC	16*25*6	5.1	15
647	TC	16*25*7	5.1	15
648	TC	16*26*3	6	15.5
649	TC	16*26*5	5	15.5
650	TC	16*26*6	5.1	15.5
651	TC	16*26*7	5	16
652	TC	16*26*9	5.1	16.5
653	TC	16*27*6	5.2	16
654	TC	16*27*7	5.2	16
655	TC	16*27*8	5.2	16
656	TC	16*28*6	5.5	16
657	TC	16*28*7	5.5	16
658	TC	16*28*8	5.5	16
659	TC	16*28.5*7	5.5	16
660	TC	16*28.6*10	6	20
661	TC	16*29*7	5.4	16
662	TC	16*30*4.5	5.5	18
663	TC	16*30*5	5.5	18
664	TC	16*30*6	5	18
665	TC	16*30*7	5.2	18
666	TC	16*30*7.5	5.5	18
667	TC	16*30*8	5.5	18
668	TC	16*30*10	5.8	18
669	TC	16*31*7	5.6	18
670	TC	16*32*7	5.7	18
671	TC	16*32*7.5	5.7	18
672	TC	16*32*8	5.7	18
673	TC	16*32*10	6.5	21
674	TC	16*33*4	6	18.5
675	TC	16*33*7	6	18.5
676	TC	16*34*7	6.5	18.5
677	TC	16*35*6	7	19.5
678	TC	16*35*7	6	19.5
679	TC	16*35*8	7	19.5
680	TC	16*35*10	7	23
681	TC	16*36*7	7	20
682	TC	16*36*8	6.5	20
683	TC	16*37*7	7	20
684	TC	16*38*7	7	21
685	TC	16*38*8	7.5	21
686	TC	16*40*7	8	23
687	TC	16*40*8	7.5	23
688	TC	16*40*10	7.5	25
689	TC	16*42*10	8	28
690	TC	16*45*10	8.5	30
691	TC	16*47*7	9.5	29
692	TC	16*47*10	9.5	32
693	TC	16*48*8	9	30
694	TC	16.5*21.5*5.4	5	13
695	TC	16.5*25*5	5.1	17
696	TC	17*22*3	4.9	17
697	TC	17*23*3	4.6	17
698	TC	17*23*4	5	17
699	TC	17*23*10	6	17
700	TC	17*24*2.5	4.6	17
701	TC	17*24*4	4.6	14.5
702	TC	17*24*5	4.6	14.5
703	TC	17*24*7	5.1	14.5

现货油封 OIL SEAL IN STOCK

序号	类型	规格	丁腈橡胶单价RMB	氟橡胶单价RMB
NO.	TYPE	SPECIFICATION	NBR PRICE	FKM PRICE
704	TC	17*25*3	5	15
705	TC	17*25*4	5	15
706	TC	17*25*5	5.1	15
707	TC	17*25*6	5.1	15
708	TC	17*25*7	5	15
709	TC	17*25*10	5.5	20
710	TC	17*26*2	5	18.2
711	TC	17*26*5	5	15.5
712	TC	17*26*6	5.1	15.5
713	TC	17*26*7	5.3	16
714	TC	17*27*4	5	15.5
715	TC	17*27*6	5	15.5
716	TC	17*27*7	5.2	16
717	TC	17*27*8	5.3	16
718	TC	17*27*10	6	20
719	TC	17*28*4.5	6	16
720	TC	17*28*5	6	16
721	TC	17*28*5.5	5.5	16
722	TC	17*28*6	5	16
723	TC	17*28*6.5	5.2	16
724	TC	17*28*7	5	16
725	TC	17*28*8	5.2	16
726	TC	17*28*10	6	19
727	TC	17*28.5*7	5.5	16
728	TC	17*28.58*7	5.5	16
729	TC	17*29*5	5	16
730	TC	17*29*6	5.2	16
731	TC	17*29*7	5.4	16
732	TC	17*29*8	5.5	16
733	TC	17*30*4.4	6	18
734	TC	17*30*4.5	6	18
735	TC	17*30*5	6	18
736	TC	17*30*6	5	18
737	TC	17*30*7	5.1	18
738	TC	17*30*8	5.7	18
739	TC	17*30*10	6	20
740	TC	17*30*6/6.5	6	20.3
741	TC	17*31*5	5.5	18
742	TC	17*31*7	5.5	18
743	TC	17*31*10	6	22
744	TC	17*32*5	5.5	17
745	TC	17*32*6	6.5	17
746	TC	17*32*7	5.5	18
747	TC	17*32*8	5.6	18
748	TC	17*32*9	6	21
749	TC	17*32*10	6.5	21
750	TC	17*33*4	6	18.5
751	TC	17*33*7	6	18.5
752	TC	17*34*4	6.5	18.5
753	TC	17*34*6	6.5	18.5
754	TC	17*34*7	6.5	18.5
755	TC	17*34*8	6.5	20
756	TC	17*35*5	7	19.5
757	TC	17*35*6	7	19.5
758	TC	17*35*7	6	19.5
759	TC	17*35*8	6	19.5
760	TC	17*35*10	6	23
761	TC	17*36*6	7	20
762	TC	17*36*7	7	20
763	TC	17*37*7	7	20
764	TC	17*37*9	6.5	21
765	TC	17*37*10	8	25
766	TC	17*38*7	7	21
767	TC	17*38*8	7.5	21
768	TC	17*38*10	7.5	24
769	TC	17*40*5	7.5	23
770	TC	17*40*6	7.5	23
771	TC	17*40*7	7.5	23
772	TC	17*40*8	7.5	23
773	TC	17*40*8.5	7.5	25
774	TC	17*40*10	7.5	25
775	TC	17*41*7	8	23

序号	类型	规格	丁腈橡胶单价RMB	氟橡胶单价RMB
NO.	TYPE	SPECIFICATION	NBR PRICE	FKM PRICE
776	TC	17*41*10	8	28
777	TC	17*42*7	8	24
778	TC	17*42*8	8	24
779	TC	17*43*9	8	27
780	TC	17*45*7	8	27
781	TC	17*46*6	8.5	28
782	TC	17*47*7	8.5	29
783	TC	17*47*8	8.5	29
784	TC	17*47*10	9	30
785	TC	17*48*7	9	30
786	TC	17.4*28.55*6.35	5.5	16
787	TC	17.4*28.6*6.3	5.5	16
788	TC	17.46*28.58*6.9	6.5	16
789	TC	17.5*26*3	6	19.5
790	TC	17.5*28.6*6.9	5.5	16
791	TC	17.5*32*7	6.5	18
792	TC	18*22*7	5.1	17
793	TC	18*24*4	4.5	14.5
794	TC	18*24*5	4.5	14.5
795	TC	18*24*6	5.1	14.5
796	TC	18*24*7	5.1	14.5
797	TC	18*25*4	5	15
798	TC	18*25*5	5	15
799	TC	18*25*6	5	15
800	TC	18*25*7	5.1	15
801	TC	18*25.3*7	7	16
802	TC	18*26*4	5	15.5
803	TC	18*26*4.5	5	15.5
804	TC	18*26*5	5.1	15.5
805	TC	18*26*6	5.1	15.5
806	TC	18*26*7	5.2	16
807	TC	18*27*7	5.1	16
808	TC	18*28*4.5	5.1	16
809	TC	18*28*5	5.1	16
810	TC	18*28*6	5	16
811	TC	18*28*7	5	16
812	TC	18*28*8	5.2	16
813	TC	18*28*10	6	18
814	TC	18*29*7	5.4	16
815	TC	18*30*5	5.2	18
816	TC	18*30*5.5	5.3	18
817	TC	18*30*6	5.4	18
818	TC	18*30*7	5	18
819	TC	18*30*8	5.2	18
820	TC	18*30*10	5.8	20
821	TC	18*30*7/7.5	6	20.9
822	TC	18*31*7	5.6	18
823	TC	18*32*6	6.5	17
824	TC	18*32*7	5.5	18
825	TC	18*32*8	5.7	18
826	TC	18*32*8.5	6.5	19.5
827	TC	18*32*10	6.5	21
828	TC	18*33*7	6.5	18.5
829	TC	18*34*7	6.5	18.5
830	TC	18*34*8	6.5	18.5
831	TC	18*35*7	6	19.5
832	TC	18*35*8	6	19.5
833	TC	18*35*10	6	23
834	TC	18*36*7	7	20
835	TC	18*36*10	7	21
836	TC	18*37*7	7	20
837	TC	18*37*8	7	20
838	TC	18*38*7	7	21
839	TC	18*38*10	7	24
840	TC	18*39*7	8	21
841	TC	18*40*7	7.5	23
842	TC	18*40*8	7.5	23
843	TC	18*40*10	7.5	25
844	TC	18*40.5*5	8	25
845	TC	18*41*10	8	28
846	TC	18*42*7	8	24
847	TC	18*42*10	8	29

现货油封 OIL SEAL IN STOCK

序号	类型	规格	丁腈橡胶单价RMB	氟橡胶单价RMB
NO.	TYPE	SPECIFICATION	NBR PRICE	FKM PRICE
848	TC	18*45*10	9	31
849	TC	18*47*8	8.5	29
850	TC	18*47*10	9	30
851	TC	18.20*30*6	5.5	18
852	TC	18.5*26*2.7	6	19.5
853	TC	18.5*28*7	6	16
854	TC	18.5*35*7	6	19.5
855	TC	18.9*28*5	5.5	16
856	TC	18.9*30*5	5	18
857	TC	19*25*6	5	15
858	TC	19*25*7	5.5	15
859	TC	19*25*8	5	18.5
860	TC	19*26*3	6	16
861	TC	19*26*5	5	16
862	TC	19*26*7	5	16
863	TC	19*27*5	5.1	15.5
864	TC	19*27*6	5.2	15.5
865	TC	19*27*7	5.2	16
866	TC	19*27*10	6	18
867	TC	19*28*7	5.2	16
868	TC	19*29*7	5.3	16
869	TC	19*30*5	5.2	18
870	TC	19*30*6.5	5.4	18
871	TC	19*30*7	5.4	18
872	TC	19*30*8	5.5	18
873	TC	19*30*10	5.7	20
874	TC	19*31*7	5.5	18
875	TC	19*31.7*6.4	6.5	18
876	TC	19*32*4	6.5	18
877	TC	19*32*5	5.5	18
878	TC	19*32*6	5.5	18
879	TC	19*32*7	5.5	18
880	TC	19*32*8	5.7	18
881	TC	19*32*8.5	6.5	18
882	TC	19*32*10	6.5	21
883	TC	19*33*7	6	18.5
884	TC	19*33*8	6	18.5
885	TC	19*33.3*7.9	6.5	21
886	TC	19*33.35*10	6.5	22
887	TC	19*33.5*8	6.5	21
888	TC	19*34*7	6.5	18.5
889	TC	19*34*8	6.5	18.5
890	TC	19*35*5	7	19.5
891	TC	19*35*6	7	19.5
892	TC	19*35*7	6	19.5
893	TC	19*35*8	7	22
894	TC	19*35*10	6.5	22
895	TC	19*35*10.3	7	25
896	TC	19*36*6	7	20
897	TC	19*36*6.5	7	20
898	TC	19*36*7	7	20
899	TC	19*36*8	7	23
900	TC	19*37*7	7	20
901	TC	19*37*10	7	23
902	TC	19*38*6	7	21
903	TC	19*38*7	7	21
904	TC	19*38*8	7	23
905	TC	19*38*10	7.5	24
906	TC	19*38*7/8	7.5	30.5
907	TC	19*39*7	8	22
908	TC	19*40*7	7.5	23
909	TC	19*40*10	7.5	25
910	TC	19*41*7	8	23
911	TC	19*42*7	8	24
912	TC	19*42*10	8.1	30
913	TC	19*43*7	8	25
914	TC	19*43*8	8	27
915	TC	19*44.4*6.3	9	28
916	TC	19*45*7	8	27
917	TC	19*45*10	8.5	31
918	TC	19*45.5*7	9	30
919	TC	19*47*7	8.5	29

序号	类型	规格	丁腈橡胶单价RMB	氟橡胶单价RMB
NO.	TYPE	SPECIFICATION	NBR PRICE	FKM PRICE
920	TC	19*47*8	8.5	30
921	TC	19*47*10	9	30
922	TC	19.05*28.57*4.76	5.4	18
923	TC	19.05*33.33*7.95	6.5	21
924	TC	19.05*33.34*7.93	6.5	21
925	TC	19.05*33.73*6.35	8	21
926	TC	19.05*35.1*7	7	25
927	TC	19.35*35*10	7	25
928	TC	19.4*31*7	5.5	18
929	TC	19.5*34.52*6.35	6.5	18.5
930	TC	19.5*35*10	7	25
931	TC	19.8*30*5	5.5	18
932	TC	19.8*30*7	5.5	18
933	TC	20*25*4	5	18.5
934	TC	20*25*7	5	18.5
935	TC	20*25*8	5	18.5
936	TC	20*25.5*7	5	18.5
937	TC	20*26*3	5	18.5
938	TC	20*26*3.5	6	18.5
939	TC	20*26*4	5	15.5
940	TC	20*26*4.5	5	15.5
941	TC	20*26*5	5	15.5
942	TC	20*26*7	5	16
943	TC	20*27*4	5	15.5
944	TC	20*27*5	5	15.5
945	TC	20*27*6	5	15.5
946	TC	20*28*3	5	16
947	TC	20*28*4	5	16
948	TC	20*28*5	5.5	16
949	TC	20*28*6	5	16
950	TC	20*28*7	5	16
951	TC	20*28*8	5	16
952	TC	20*28.5*5	5.5	16
953	TC	20*28.6*5	5.1	16
954	TC	20*30*4.5	5.2	18
955	TC	20*30*5	5	18
956	TC	20*30*6	5.5	18
957	TC	20*30*7	5	18
958	TC	20*30*8	5.5	18
959	TC	20*30*9	5.6	18
960	TC	20*30*10	5.7	19
961	TC	20*31*6	5.5	18
962	TC	20*31*7	5.5	18
963	TC	20*32*5	5.5	18
964	TC	20*32*6	5.5	18
965	TC	20*32*7	5.5	18
966	TC	20*32*7.5	5.6	18
967	TC	20*32*8	5.5	18
968	TC	20*32*10	6.1	21
969	TC	20*32*7/8	6.5	22.4
970	TC	20*33*7	6	18.5
971	TC	20*33*10	6.5	21
972	TC	20*33*12	6.5	25
973	TC	20*34*4	6.5	18.5
974	TC	20*34*6	6.5	18.5
975	TC	20*34*7	6.5	18.5
976	TC	20*35*4	7.5	19.5
977	TC	20*35*5	6	19.5
978	TC	20*35*5.5	6.5	19.5
979	TC	20*35*6	6	19.5
980	TC	20*35*7	6	19.5
981	TC	20*35*8	7	19.5
982	TC	20*35*9	6	21
983	TC	20*35*10	7	23
984	TC	20*35*12	7.5	24
985	TC	20*35*7/10	7.5	34.4
986	TC	20*36*5	7	20
987	TC	20*36*6	7	20
988	TC	20*36*7	7	20
989	TC	20*36*8	7	20
990	TC	20*36*10	7.5	23
991	TC	20*36*15	10	28

现货油封 OIL SEAL IN STOCK

序号	类型	规格	丁腈橡胶单价RMB	氟橡胶单价RMB
NO.	TYPE	SPECIFICATION	NBR PRICE	FKM PRICE
992	TC	20*37*6	7	20
993	TC	20*37*6.5	7	20
994	TC	20*37*7	7	20
995	TC	20*37*8	7	20
996	TC	20*37*10	7.5	22
997	TC	20*38*5	7	21
998	TC	20*38*6	7	21
999	TC	20*38*7	7	21
1000	TC	20*38*8	7	21
1001	TC	20*38*10	7	25
1002	TC	20*39*6	8	21
1003	TC	20*40*4	7.5	23
1004	TC	20*40*5	7.5	23
1005	TC	20*40*6	7.5	23
1006	TC	20*40*6.5	7.5	23
1007	TC	20*40*7	7.5	23
1008	TC	20*40*8	7.5	23
1009	TC	20*40*9	7.5	25
1010	TC	20*40*10	7.5	25
1011	TC	20*40*11	8.1	29
1012	TC	20*40*12	8.1	29
1013	TC	20*40.6*11	8	27
1014	TC	20*41*7	7.5	23
1015	TC	20*41.25*7	8	25
1016	TC	20*41.3*7	8	25
1017	TC	20*42*5	7.5	24
1018	TC	20*42*6	7.5	24
1019	TC	20*42*7	7.5	24
1020	TC	20*42*8	7.5	24
1021	TC	20*42*9	7.5	28
1022	TC	20*42*10	7.5	28
1023	TC	20*42*12	8.5	30
1024	TC	20*43*7	7.5	25
1025	TC	20*44*7	8	26
1026	TC	20*45*5	7.5	27
1027	TC	20*45*7	7.5	27
1028	TC	20*45*8	8	27
1029	TC	20*45*10	8.5	29
1030	TC	20*45*12	9	30
1031	TC	20*46*7	8.5	28
1032	TC	20*46*8	8.5	28
1033	TC	20*47*5	8	29
1034	TC	20*47*7	8	29
1035	TC	20*47*8	8	29
1036	TC	20*47*10	8	29
1037	TC	20*47*12	9.2	32
1038	TC	20*47.10*10	9	33
1039	TC	20*48*7	9	30
1040	TC	20*48*10	9	31
1041	TC	20*49*7	9.5	31
1042	TC	20*49*8	9.5	31
1043	TC	20*50*7	9.5	32
1044	TC	20*50*8	9.5	32
1045	TC	20*50*9	10	32
1046	TC	20*50*10	9.5	32
1047	TC	20*52*6	9.5	33.5
1048	TC	20*52*7	9.5	33.5
1049	TC	20*52*8	9.5	33.5
1050	TC	20*52*9	9.5	33.5
1051	TC	20*52*10	9.5	33.5
1052	TC	20*52*12	10	33.5
1053	TC	20*53*7	9.5	34
1054	TC	20*55*7	10.3	40
1055	TC	20*60*10	12	48
1056	TC	20*62*6.5	13	48
1057	TC	20*68*14	14	75
1058	TC	20*37/38*8	7	25
1059	TC	21*25*2.8	6	16
1060	TC	21*26*4	6	15.5
1061	TC	21*27*5	5	16
1062	TC	21*31*7	6.5	18
1063	TC	21*32*5	6.5	18

序号	类型	规格	丁腈橡胶单价RMB	氟橡胶单价RMB
NO.	TYPE	SPECIFICATION	NBR PRICE	FKM PRICE
1064	TC	21*32*5.5	6.5	18
1065	TC	21*32*7	5.5	18
1066	TC	21*32*7.5	5.6	18
1067	TC	21*33*7	6	18.5
1068	TC	21*35*7	7.5	19.5
1069	TC	21*35*10	6.4	23
1070	TC	21*36*7	7	20
1071	TC	21*37*5	7	20
1072	TC	21*37*7	7	20
1073	TC	21*37*8	7	22
1074	TC	21*38*10	7	25
1075	TC	21*40*6	7.5	23
1076	TC	21*40*7	7.5	23
1077	TC	21*40*10	7.5	25
1078	TC	21*40*5/7	7.5	26.2
1079	TC	21*40.5*7	8	25
1080	TC	21*45*7	8	27
1081	TC	21*45*10	8.5	29
1082	TC	21*52*9	9.5	33.5
1083	TC	22*27*12	6	21
1084	TC	22*28*4	5	16
1085	TC	22*28*7	5.2	16
1086	TC	22*28*8	6	16
1087	TC	22*28.5*4	5	16
1088	TC	22*29*4	6	18
1089	TC	22*30*4	5.2	18
1090	TC	22*30*5	5.5	18
1091	TC	22*30*7	5.5	18
1092	TC	22*30*8	6	18
1093	TC	22*31*5	5.5	18
1094	TC	22*31*7	5.5	18
1095	TC	22*32*4	6	18
1096	TC	22*32*5	6	18
1097	TC	22*32*5.5	6.5	18
1098	TC	22*32*6	5.5	18
1099	TC	22*32*7	6	18
1100	TC	22*32*8	6	18
1101	TC	22*33*7	6	18.5
1102	TC	22*33*10	6.5	21
1103	TC	22*34*5	6.5	18.5
1104	TC	22*34*6	6.5	18.5
1105	TC	22*34*7	6.5	18.5
1106	TC	22*34*8	6.5	18.5
1107	TC	22*34*10	7	21
1108	TC	22*34*10/15	8	28
1109	TC	22*34.5*6	6.5	18.5
1110	TC	22*34.5*6.5	6.5	18.5
1111	TC	22*35*5	7	19.5
1112	TC	22*35*5.5	7	19.5
1113	TC	22*35*6	7	19.5
1114	TC	22*35*7	7	19.5
1115	TC	22*35*8	7	19.5
1116	TC	22*35*10	7	21
1117	TC	22*36*5	7	20
1118	TC	22*36*5.5	7	20
1119	TC	22*36*6	7	20
1120	TC	22*36*7	7	20
1121	TC	22*36*8	7	22
1122	TC	22*36*10	7	22
1123	TC	22*36*7.5/11	7	31.6
1124	TC	22*36.1*7	7	20
1125	TC	22*37*5	7	20
1126	TC	22*37*6	7	20
1127	TC	22*37*7	7	20
1128	TC	22*37*8	7	20
1129	TC	22*37*8/9	7.5	26.3
1130	TC	22*38*5	7	21
1131	TC	22*38*6	7	21
1132	TC	22*38*7	7	21
1133	TC	22*38*8	7	21
1134	TC	22*38*10	7	23
1135	TC	22*38.1*8	7	23

现货油封 OIL SEAL IN STOCK

序号	类型	规格	丁腈橡胶单价RMB	氟橡胶单价RMB
NO.	TYPE	SPECIFICATION	NBR PRICE	FKM PRICE
1136	TC	22*39*6	8	21
1137	TC	22*39*7	8	21
1138	TC	22*39*8	8	21
1139	TC	22*39*9	8	22
1140	TC	22*40*4	7.5	23
1141	TC	22*40*7	7.5	23
1142	TC	22*40*8	7.5	23
1143	TC	22*40*10	7.5	25
1144	TC	22*40*12	8	28
1145	TC	22*40*16	10	35
1146	TC	22*40*5/7	7.5	26.2
1147	TC	22*40*7/8	7.5	26.2
1148	TC	22*41*5	7.5	23
1149	TC	22*41*7	7.5	23
1150	TC	22*41.25*6	8	25
1151	TC	22*41.25*7	8	25
1152	TC	22*41.3*6	8	25
1153	TC	22*41.3*7	8	25
1154	TC	22*42*5	8	24
1155	TC	22*42*7	7.5	24
1156	TC	22*42*8	7.5	24
1157	TC	22*42*10	7.8	25
1158	TC	22*42*11	8	26
1159	TC	22*42*12	8.5	28
1160	TC	22*43*7	7.5	25
1161	TC	22*43*8	8	25
1162	TC	22*44*6	8	26
1163	TC	22*44*7	8	26
1164	TC	22*44*8	8	26
1165	TC	22*44*9	8	27
1166	TC	22*45*7	8	27
1167	TC	22*45*8	8	27
1168	TC	22*45*9	8	27
1169	TC	22*45*10	8.5	29
1170	TC	22*46*8	8.5	28
1171	TC	22*47*5	8.5	29
1172	TC	22*47*7	8	29
1173	TC	22*47*8	8.5	29
1174	TC	22*47*9	8.5	29
1175	TC	22*47*10	8.8	30
1176	TC	22*47*12	9	36
1177	TC	22*48*7	9	30
1178	TC	22*48*8	9	31
1179	TC	22*48*10	9	31
1180	TC	22*48*11	10	32
1181	TC	22*50*5	9.5	32
1182	TC	22*50*7	9.5	32
1183	TC	22*50*8	9.5	32
1184	TC	22*50*10	9.5	32
1185	TC	22*50*12	9.8	35
1186	TC	22*52*7	9.5	33.5
1187	TC	22*52*8	9.5	33.5
1188	TC	22*52*10	10	33.5
1189	TC	22*55*7	11	40
1190	TC	22*56*7	11	43
1191	TC	22.2*31.7*6.3	5.5	18
1192	TC	22.2*38.1*6.3	7	23
1193	TC	22.2*41.3*9.5	8	28
1194	TC	22.22*34.92*6.35	6.5	18.5
1195	TC	22.225*31.75*6.35	5.5	18
1196	TC	22.33*34.925*6.35	6.5	18.5
1197	TC	22.7*47*7	8.5	29
1198	TC	23*30*4	6	18
1199	TC	23*30*5	6	18
1200	TC	23*32*5	6	18
1201	TC	23*32*7	6	18
1202	TC	23*34*6.5	6.5	18.5
1203	TC	23*34*8	6.5	18.5
1204	TC	23*35*5	7.5	19.5
1205	TC	23*35*6	7.5	19.5
1206	TC	23*35*7	7	19.5
1207	TC	23*35*8	7.5	19.5

序号	类型	规格	丁腈橡胶单价RMB	氟橡胶单价RMB
NO.	TYPE	SPECIFICATION	NBR PRICE	FKM PRICE
1208	TC	23*36*6	7	20
1209	TC	23*36*7	7	20
1210	TC	23*36*10	7.5	24
1211	TC	23*37*7	7	20
1212	TC	23*37*9	7	23
1213	TC	23*38*6	7	21
1214	TC	23*38*7	7	21
1215	TC	23*38*8	7	21
1216	TC	23*38*9	7	23
1217	TC	23*38*10	7.5	24
1218	TC	23*39*8	8	21
1219	TC	23*40*6	7.5	23
1220	TC	23*40*7	7.5	23
1221	TC	23*40*8	7.5	23
1222	TC	23*40*10	7.5	25
1223	TC	23*42*7	8	24
1224	TC	23*42*8	8	24
1225	TC	23*42*10	8	25
1226	TC	23*43*7	7.5	25
1227	TC	23*43*8	8	27
1228	TC	23*43*10	9	29
1229	TC	23*45*8	8	27
1230	TC	23*47*7	8.5	29
1231	TC	23*47*8	8.5	29
1232	TC	23*47*10	8.8	30
1233	TC	23*68*8	14	53
1234	TC	23.5*30*4	7	23
1235	TC	23.5*40*7	7.5	23
1236	TC	23.8*38.1*9.5	7	23
1237	TC	24*31*4	5.5	18
1238	TC	24*31*5	6	18
1239	TC	24*32*4	6	18
1240	TC	24*32*7	6	18
1241	TC	24*32*10	6.5	21
1242	TC	24*33*7	6	18.5
1243	TC	24*34*5	6.5	18.5
1244	TC	24*34*6	6.5	18.5
1245	TC	24*34*7	6.5	18.5
1246	TC	24*34*8	6.5	19
1247	TC	24*34.5*11	7	25
1248	TC	24*35*5	6	19.5
1249	TC	24*35*6	7.5	19.5
1250	TC	24*35*7	7	19.5
1251	TC	24*35*8	7	19.5
1252	TC	24*35*10	7	21
1253	TC	24*36*6	7	20
1254	TC	24*36*7	7	20
1255	TC	24*36*7.5	7	20
1256	TC	24*36*8	7	20
1257	TC	24*36*5.4/6.1	7.5	20
1258	TC	24*36*7/7.5	7	20
1259	TC	24*37*7	7	20
1260	TC	24*37*8.1	7	23
1261	TC	24*38*5	7	21
1262	TC	24*38*7	7	21
1263	TC	24*38*8	7	21
1264	TC	24*38*10	7.5	23
1265	TC	24*38.5*10	7.5	24
1266	TC	24*40*4	7.5	23
1267	TC	24*40*7	7.5	23
1268	TC	24*40*7.4	7	23
1269	TC	24*40*7.5	7	23
1270	TC	24*40*8	7.5	23
1271	TC	24*40*8.5	7.5	25
1272	TC	24*40*10	7.5	25
1273	TC	24*40.1*10	8	25
1274	TC	24*41.25*7	8	25
1275	TC	24*42*7	8	24
1276	TC	24*42*8	7.5	24
1277	TC	24*42*10	8	27
1278	TC	24*43*6	8	25
1279	TC	24*43*7	8	25

现货油封 OIL SEAL IN STOCK

序号	类型	规格	丁腈橡胶单价RMB	氟橡胶单价RMB
NO.	TYPE	SPECIFICATION	NBR PRICE	FKM PRICE
1280	TC	24*43*8.5	8	29
1281	TC	24*44*7	8	26
1282	TC	24*45*6	8	27
1283	TC	24*45*7	8	27
1284	TC	24*45*8	8	27
1285	TC	24*45*10	8.5	29
1286	TC	24*45*11	8.5	33
1287	TC	24*46*8	8.5	28
1288	TC	24*46*10	8.5	29
1289	TC	24*47*7	8.5	29
1290	TC	24*47*10	8.5	30
1291	TC	24*48*7	9	30
1292	TC	24*48*8	10	30
1293	TC	24*49*8	9.5	31
1294	TC	24*49*12	9.5	34
1295	TC	24*50*7	9	32
1296	TC	24*50*8	9	32
1297	TC	24*50*10	9	32
1298	TC	24*50*12	9.8	35
1299	TC	24*52*7	9.5	33.5
1300	TC	24*52*8	9.5	33.5
1301	TC	24*52*10	9.5	33.5
1302	TC	24*52*12	10.5	33.5
1303	TC	24*54*8	10	35
1304	TC	24*55*10	11	43
1305	TC	24*60*10	12	52
1306	TC	24*62*8	12	48
1307	TC	24.5*37.93*6	7	21
1308	TC	24.5*38*6	7	21
1309	TC	24.5*42*7	7.5	24
1310	TC	25*30*7	5.5	18
1311	TC	25*30*15	10	18
1312	TC	25*31*5	5.5	18
1313	TC	25*31*6	5.5	18
1314	TC	25*31*7	5.5	18
1315	TC	25*32*4	6	18
1316	TC	25*32*5	6	18
1317	TC	25*32*6	6	18
1318	TC	25*32*7	6	18
1319	TC	25*33*4	6	18.5
1320	TC	25*33*6	6	18.5
1321	TC	25*33*7	6	18.5
1322	TC	25*33*10	6.5	21
1323	TC	25*33.5*7	6.5	21
1324	TC	25*34*5	6.5	18.5
1325	TC	25*34*6	6.5	18.5
1326	TC	25*34*7	6.5	18.5
1327	TC	25*35*4	7	19.5
1328	TC	25*35*5	7	19.5
1329	TC	25*35*6	7	19.5
1330	TC	25*35*7	7	19.5
1331	TC	25*35*8	7	19.5
1332	TC	25*35*9	7	19.5
1333	TC	25*35*10	7	20
1334	TC	25*35*9/10	8	25.2
1335	TC	25*36*6	7	20
1336	TC	25*36*7	7	20
1337	TC	25*36*8	7	20
1338	TC	25*36*10	7	23
1339	TC	25*36.3*7.38	7	20
1340	TC	25*36.5*7	7	20
1341	TC	25*37*5	7	20
1342	TC	25*37*6	7	20
1343	TC	25*37*7	7	20
1344	TC	25*37*7.3	7	20
1345	TC	25*37*8	7	20
1346	TC	25*37*10	7.5	23
1347	TC	25*38*5	7	21
1348	TC	25*38*6	7	21
1349	TC	25*38*6.4	7	21
1350	TC	25*38*7	7	21
1351	TC	25*38*7.5	7	23

序号	类型	规格	丁腈橡胶单价RMB	氟橡胶单价RMB
NO.	TYPE	SPECIFICATION	NBR PRICE	FKM PRICE
1352	TC	25*38*8	7	21
1353	TC	25*38*10	7	22
1354	TC	25*38.2*7.2	7	23
1355	TC	25*39*5	7.5	21
1356	TC	25*39*7	7.5	21
1357	TC	25*39*8	8	21
1358	TC	25*40*3	7.5	23
1359	TC	25*40*4	7.5	23
1360	TC	25*40*5	7.5	23
1361	TC	25*40*6	7.5	23
1362	TC	25*40*7	7.5	23
1363	TC	25*40*7.5	7.5	23
1364	TC	25*40*8	7.5	23
1365	TC	25*40*8.9	7.5	25
1366	TC	25*40*9	7.5	25
1367	TC	25*40*10	7.5	25
1368	TC	25*40*12	7.8	29
1369	TC	25*40*10/12	10	36.2
1370	TC	25*41*6	7.5	23
1371	TC	25*41*7	7.5	23
1372	TC	25*41*10	7.5	28
1373	TC	25*41*11	7.5	28
1374	TC	25*41.1*6	8	25
1375	TC	25*41.1*8	8	25
1376	TC	25*41.25*6	8	25
1377	TC	25*41.25*7	8	25
1378	TC	25*41.25*8	8	25
1379	TC	25*41.28*7	8	25
1380	TC	25*41.3*6	8	25
1381	TC	25*41.3*7	8	25
1382	TC	25*41.5*7	8	25
1383	TC	25*41.55*10	10	28
1384	TC	25*42*4	7.5	24
1385	TC	25*42*5	7.5	24
1386	TC	25*42*5.5	7.5	24
1387	TC	25*42*6	7.5	24
1388	TC	25*42*7	7.5	24
1389	TC	25*42*8	7.5	24
1390	TC	25*42*10	7.5	27
1391	TC	25*42*12	8.5	29
1392	TC	25*43*6	8	25
1393	TC	25*43*7	8	25
1394	TC	25*43*8	7.5	25
1395	TC	25*43*9	7.5	26
1396	TC	25*43*10	8	27
1397	TC	25*43*12	8	30
1398	TC	25*43.1*10	8	30
1399	TC	25*44*6	7.5	26
1400	TC	25*44*7	7.5	26
1401	TC	25*44*8	8	26
1402	TC	25*44*10	8.2	28
1403	TC	25*44.5*6	9	28
1404	TC	25*44.5*6/9	9	28
1405	TC	25*44.6*6	9	28
1406	TC	25*45*5	9	28
1407	TC	25*45*7	7.5	27
1408	TC	25*45*8	8	27
1409	TC	25*45*9	8	27
1410	TC	25*45*10	8	29
1411	TC	25*45*11	9	30
1412	TC	25*45*12	9	31
1413	TC	25*45.2*10	8.5	30
1414	TC	25*46*7	8.5	28
1415	TC	25*46*10	9	29
1416	TC	25*47*5	9	29
1417	TC	25*47*6	8.5	29
1418	TC	25*47*7	8	29
1419	TC	25*47*8	8	29
1420	TC	25*47*9	8	30
1421	TC	25*47*10	8	30
1422	TC	25*47*12	9	33
1423	TC	25*47*8/11.5	8.5	30

现货油封 OIL SEAL IN STOCK

序号	类型	规格	丁腈橡胶单价RMB	氟橡胶单价RMB
NO.	TYPE	SPECIFICATION	NBR PRICE	FKM PRICE
1424	TC	25*48*7	9	30
1425	TC	25*48*8	9	30
1426	TC	25*48*10	9	31
1427	TC	25*49*10	9.5	32
1428	TC	25*49.7*10.5/15	9.5	32
1429	TC	25*50*7	9	32
1430	TC	25*50*8	9	32
1431	TC	25*50*9	10	32
1432	TC	25*50*10	8.5	32
1433	TC	25*50*12	9.8	35
1434	TC	25*50.55*10	10	33
1435	TC	25*51*10	9.5	35
1436	TC	25*52*4	10	33.5
1437	TC	25*52*5	9	30
1438	TC	25*52*6	9.5	33.5
1439	TC	25*52*7	9	33.5
1440	TC	25*52*8	9.5	33.5
1441	TC	25*52*9	9.5	33.5
1442	TC	25*52*10	9.5	33.5
1443	TC	25*52*11	10	33.5
1444	TC	25*52*11.5	10	33.5
1445	TC	25*52*12	10	33.5
1446	TC	25*52*10/14	10	33.5
1447	TC	25*53*10	9.5	35
1448	TC	25*53.5*10	10	35
1449	TC	25*54*8	11	35
1450	TC	25*54*10	11	36
1451	TC	25*55*8	10.3	41
1452	TC	25*55*10	11.2	28
1453	TC	25*55*12	12	49
1454	TC	25*55*15	13.5	60
1455	TC	25*56*12	11.8	48
1456	TC	25*58*8	11.5	45
1457	TC	25*58*10	12	46
1458	TC	25*60*7	11.5	46
1459	TC	25*60*8	11.5	46
1460	TC	25*60*10	12.5	47
1461	TC	25*62*6	12	48
1462	TC	25*62*7	12	48
1463	TC	25*62*7.5	12	48
1464	TC	25*62*8	12	48
1465	TC	25*62*10	12	48
1466	TC	25*62*12	13.5	55
1467	TC	25*63*8	13	49
1468	TC	25*64*9	13	50
1469	TC	25*65*7	13	51
1470	TC	25*65*10	13	54
1471	TC	25*65*12	13	54
1472	TC	25*66*8.5	14	53
1473	TC	25*68*10	13.5	53
1474	TC	25*70*10	15	58
1475	TC	25*72*7	15	59
1476	TC	25*72*8	15	59
1477	TC	25*72*10	15.6	59
1478	TC	25*80*10	20	68
1479	TC	25*80*12	20	68
1480	TC	25.25*41*7	7.5	25
1481	TC	25.4*34.9*6.3	6.5	18.5
1482	TC	25.4*36.5*6.4	7	20
1483	TC	25.4*38.1*6.3	7	23
1484	TC	25.4*41.2*6.3	8	25
1485	TC	25.4*44.45*6.35	9	28
1486	TC	25.4*44.45*9.5	9	28
1487	TC	25.4*44.45*9.525	9	30
1488	TC	25.4*44.5*6.3	8	28
1489	TC	25.4*50.8*7.9	10	33
1490	TC	25.4*50.8*9.525	10	33
1491	TC	25.4*50.8*12.7	12	33
1492	TC	25.5*36*5	7	20
1493	TC	25.5*37.5*6	7	21
1494	TC	25.7*40.8*7.7	8	25
1495	TC	26*32*4	6	18.5

序号	类型	规格	丁腈橡胶单价RMB	氟橡胶单价RMB
NO.	TYPE	SPECIFICATION	NBR PRICE	FKM PRICE
1496	TC	26*32*7	6.5	18.5
1497	TC	26*34*4	6.5	18.5
1498	TC	26*34*7	6.5	18.5
1499	TC	26*35*5	6.5	19.5
1500	TC	26*35*6	7	19.5
1501	TC	26*35*7	7	19.5
1502	TC	26*36*5	7	20
1503	TC	26*36*7	7	20
1504	TC	26*36*10.5	8	23
1505	TC	26*37*6	7	20
1506	TC	26*37*7	7	20
1507	TC	26*37*8	7	20
1508	TC	26*37*10.5	7	23
1509	TC	26*37.5*6	7	21
1510	TC	26*38*5	7	21
1511	TC	26*38*7	7	21
1512	TC	26*38*8	7	21
1513	TC	26*40*3	7.5	23
1514	TC	26*40*5	7.5	23
1515	TC	26*40*6	7.5	23
1516	TC	26*40*7	7.5	23
1517	TC	26*40*8	7.5	23
1518	TC	26*40*9	7.5	24
1519	TC	26*40*10	7.5	26
1520	TC	26*42*7	8	24
1521	TC	26*42*8	7.5	24
1522	TC	26*42*9	7.5	25
1523	TC	26*42*10	8	25
1524	TC	26*43*7	7.5	25
1525	TC	26*43*8	8	25
1526	TC	26*43*9	8	28
1527	TC	26*44*7	8	26
1528	TC	26*44*8	8	26
1529	TC	26*45*7	8	27
1530	TC	26*45*8	8	27
1531	TC	26*45*10	8.5	29
1532	TC	26*45.5*8	9	30
1533	TC	26*46*7	8.5	28
1534	TC	26*46*8	8.5	28
1535	TC	26*47*5	8.5	29
1536	TC	26*47*6	9	29
1537	TC	26*47*7	8.5	29
1538	TC	26*47*8	9	29
1539	TC	26*47*10	8.5	30
1540	TC	26*47*11	9	32
1541	TC	26*47*12	9.5	35
1542	TC	26*48*7	9	30
1543	TC	26*48*8	9	30
1544	TC	26*48*10	9	33
1545	TC	26*50*7	9.5	32
1546	TC	26*50*8	9.5	32
1547	TC	26*50*10	9.5	32
1548	TC	26*52*7	9.5	33.5
1549	TC	26*52*8	9.5	33.5
1550	TC	26*52*10	9.5	33.5
1551	TC	26*52*12	10	33.5
1552	TC	26*52*7/8	9.5	33.5
1553	TC	26*57*8	11	45
1554	TC	26*62*8	13	48
1555	TC	26*62*9	13	48
1556	TC	26*72*10	15.6	59
1557	TC	27*32*7	6.5	18.5
1558	TC	27*34*4	6.5	18.5
1559	TC	27*34*7	6.5	18.5
1560	TC	27*35*4	6.5	19.5
1561	TC	27*35*5	7	19.5
1562	TC	27*35*6	7	19.5
1563	TC	27*35*7	7	19.5
1564	TC	27*36*6	7	20
1565	TC	27*36*7	7	20
1566	TC	27*36*10	7.5	23
1567	TC	27*37*6	7	20

现货油封 OIL SEAL IN STOCK

序号	类型	规格	丁腈橡胶单价RMB	氟橡胶单价RMB
NO.	TYPE	SPECIFICATION	NBR PRICE	FKM PRICE
1568	TC	27*37*7	7	20
1569	TC	27*37*7.5	7	20
1570	TC	27*37*8	7	20
1571	TC	27*37*9	7	20
1572	TC	27*37*10	7	23
1573	TC	27*37*10.5	7	23
1574	TC	27*37*7.5/9.5	7	20
1575	TC	27*38*6	7	21
1576	TC	27*38*7	7	21
1577	TC	27*38*8	7	21
1578	TC	27*38*10	7	22
1579	TC	27*38.1*6.3	7	23
1580	TC	27*39*7	7.5	21
1581	TC	27*39*10	7.5	24
1582	TC	27*39*10.5	7.5	24
1583	TC	27*40*5	7.5	23
1584	TC	27*40*6	7.5	23
1585	TC	27*40*7	7.5	23
1586	TC	27*40*8	7.5	23
1587	TC	27*40*10	7.5	25
1588	TC	27*40*12	8	27
1589	TC	27*41*7	8	23
1590	TC	27*41*8	8	23
1591	TC	27*41*10	8	30
1592	TC	27*42*7	7.5	24
1593	TC	27*42*8	8	28
1594	TC	27*42*10	8	28
1595	TC	27*42.8*8	9	26
1596	TC	27*43*7	8	25
1597	TC	27*43*8	7.5	25
1598	TC	27*43*9	8	26
1599	TC	27*43*10	8	27
1600	TC	27*44*7	8	27
1601	TC	27*44*8	8	27
1602	TC	27*44*9	8.2	28
1603	TC	27*45*7	8	27
1604	TC	27*45*8	8	27
1605	TC	27*45*9	8	27
1606	TC	27*45*10	8.5	29
1607	TC	27*47*6	8.5	29
1608	TC	27*47*7	8.5	29
1609	TC	27*47*8	8.5	29
1610	TC	27*47*10	8.5	30
1611	TC	27*48*7	9	30
1612	TC	27*48*8	9	30
1613	TC	27*48*9	10	30
1614	TC	27*49*8	9.5	31
1615	TC	27*49*10	10	32
1616	TC	27*50*10	9.5	32
1617	TC	27*52*5	10	33.5
1618	TC	27*52*7	9.5	33.5
1619	TC	27*52*8	9.5	33.5
1620	TC	27*53*7	9.5	34
1621	TC	27*56*7	11	43
1622	TC	27*62*7	12	48
1623	TC	27*62*8	12	48
1624	TC	27.9*70*10	14	58
1625	TC	28*34*7	6.5	18.5
1626	TC	28*35*4	7	19.5
1627	TC	28*35*5	7	19.5
1628	TC	28*35*6	7	19.5
1629	TC	28*35*7	7	19.5
1630	TC	28*35*8	7	19.5
1631	TC	28*35*9	7	19.5
1632	TC	28*36*4	7	20
1633	TC	28*36*7	7	20
1634	TC	28*37*4	7	20
1635	TC	28*37*5	7	20
1636	TC	28*37*6	7	20
1637	TC	28*37*7	7	20
1638	TC	28*37*8	7	20
1639	TC	28*38*5	7	21

序号	类型	规格	丁腈橡胶单价RMB	氟橡胶单价RMB
NO.	TYPE	SPECIFICATION	NBR PRICE	FKM PRICE
1640	TC	28*38*5.5	7.5	21
1641	TC	28*38*6	7	21
1642	TC	28*38*6.2	7	21
1643	TC	28*38*6.5	7	21
1644	TC	28*38*7	7	21
1645	TC	28*38*8	7.5	21
1646	TC	28*38*10	7.5	23
1647	TC	28*39*6	7.5	21
1648	TC	28*39*7	8	21
1649	TC	28*40*5	7.5	23
1650	TC	28*40*6	7.5	23
1651	TC	28*40*7	7.5	23
1652	TC	28*40*8	7.5	23
1653	TC	28*40*9	8	24
1654	TC	28*40*10	7.5	25
1655	TC	28*40*8/8.5	7.8	23
1656	TC	28*40.5*8	7.5	25
1657	TC	28*40.8*8	8	25
1658	TC	28*41*7	8	23
1659	TC	28*41*8	8	23
1660	TC	28*41.25*7	9	25
1661	TC	28*41.5*8	8	25
1662	TC	28*42*6	7.5	24
1663	TC	28*42*7	7.5	24
1664	TC	28*42*8	8	24
1665	TC	28*42*10	8	26
1666	TC	28*42*11	8	30
1667	TC	28*43*6.7	8	25
1668	TC	28*43*7	8	25
1669	TC	28*43*8	8	25
1670	TC	28*43*10	8	28
1671	TC	28*43.5*6	7.5	30
1672	TC	28*44*6	8	26
1673	TC	28*44*7	8	26
1674	TC	28*44*8	8	28
1675	TC	28*45*5	8	28
1676	TC	28*45*7	8	27
1677	TC	28*45*8	7.7	27
1678	TC	28*45*10	8.5	29
1679	TC	28*46*7	8.5	28
1680	TC	28*46*8	8.5	28
1681	TC	28*46*10	10	29
1682	TC	28*47*5	8.5	29
1683	TC	28*47*7	8	29
1684	TC	28*47*8	8.5	29
1685	TC	28*47*10	8	30
1686	TC	28*47*11	8.5	32
1687	TC	28*48*6	9	30
1688	TC	28*48*7	9	30
1689	TC	28*48*8	9	30
1690	TC	28*48*10	9	31
1691	TC	28*48*11	9	34
1692	TC	28*49*8	9	31
1693	TC	28*49.5*8	10	32
1694	TC	28*50*7	9	32
1695	TC	28*50*8	9.5	32
1696	TC	28*50*10	8.5	32
1697	TC	28*50*12	9.5	35
1698	TC	28*51*10	9.5	35
1699	TC	28*52*5	9	28
1700	TC	28*52*7	9.5	33.5
1701	TC	28*52*8	9.5	33.5
1702	TC	28*52*9	9.5	33.5
1703	TC	28*52*10	9.5	33.5
1704	TC	28*52*11	10	33.5
1705	TC	28*54*10	11	36
1706	TC	28*55*8	10.3	40
1707	TC	28*55*10	10.8	45
1708	TC	28*56*7	11	43
1709	TC	28*56*8	11	43
1710	TC	28*56*9	11	43
1711	TC	28*56*10	11.3	45

现货油封 OIL SEAL IN STOCK

序号	类型	规格	丁腈橡胶单价RMB	氟橡胶单价RMB
NO.	TYPE	SPECIFICATION	NBR PRICE	FKM PRICE
1712	TC	28*57*7	11	45
1713	TC	28*58*6	11.5	45
1714	TC	28*58*7	11.5	45
1715	TC	28*58*8	11	45
1716	TC	28*58*9	11.5	46
1717	TC	28*58*10	11.5	46
1718	TC	28*60*7	11	46
1719	TC	28*62*9	13	49
1720	TC	28*62*10	13	49
1721	TC	28*70*10	14.5	58
1722	TC	28*72*10	15.6	59
1723	TC	28.3*42.3*8	7.5	26
1724	TC	28.5*36.5*8	7	20
1725	TC	28.5*39.5*9.5	7.5	24
1726	TC	28.5*41.3*6.3	8	25
1727	TC	28.5*43*7	7.5	25
1728	TC	28.5*57.15*7.9	13	45
1729	TC	28.56*39.7*9.63	8	23
1730	TC	28.575*44.45*9.525	9	28
1731	TC	28.58*38.10*4.75	7	23
1732	TC	28.58*38.1*6.35	7	23
1733	TC	28.6*40*8	8	23
1734	TC	28.6*43*6.5	7.5	25
1735	TC	29*36*8	7	20
1736	TC	29*37*10	7	21
1737	TC	29*38*6	7.5	21
1738	TC	29*38*10	7.5	23
1739	TC	29*40*7	8	23
1740	TC	29*40*8	7.5	23
1741	TC	29*40*10	8	25
1742	TC	29*41*7	8	25
1743	TC	29*41*9	8	25
1744	TC	29*41.5*3.5	10	25
1745	TC	29*42*7	7.5	24
1746	TC	29*42*10	8	26
1747	TC	29*43*7	8	25
1748	TC	29*43*8	7.5	28
1749	TC	29*43*10	8	29
1750	TC	29*43*10.5	8	29
1751	TC	29*44*7	8	26
1752	TC	29*44*8	8	26
1753	TC	29*45*8	8	27
1754	TC	29*45*9	8	27
1755	TC	29*46*7	9	28
1756	TC	29*46*8	9	28
1757	TC	29*46*10	9	29
1758	TC	29*47*7	9	29
1759	TC	29*47*8	8.5	29
1760	TC	29*47*10	9	30
1761	TC	29*48*8	10	30
1762	TC	29*48*10	10	32
1763	TC	29*49*8	10	31
1764	TC	29*50*7	9.5	32
1765	TC	29*50*8	9.5	32
1766	TC	29*50*10	9.5	32
1767	TC	29*52*7	9.5	33.5
1768	TC	29*52*10	9.5	33.5
1769	TC	29*54*9	11	36
1770	TC	29*54*10	11	37
1771	TC	29*55*10	10.8	44
1772	TC	29*56*10	11	45
1773	TC	29*62*9	12	48
1774	TC	29*62*10	12.5	53
1775	TC	29*72*10	15.6	59
1776	TC	29.1*50.29*6.35	9	33
1777	TC	29.36*42.85*7.95	9	26
1778	TC	29.4*42.8*8	9	26
1779	TC	29.5*40*10	8	25
1780	TC	30*36*5	7	20
1781	TC	30*36*7	7	20
1782	TC	30*37*4	7	20
1783	TC	30*37*6	7	20

序号	类型	规格	丁腈橡胶单价RMB	氟橡胶单价RMB
NO.	TYPE	SPECIFICATION	NBR PRICE	FKM PRICE
1784	TC	30*37*7	7	20
1785	TC	30*37*8	7	20
1786	TC	30*38*4	7.5	21
1787	TC	30*38*5	7.5	21
1788	TC	30*38*6	7.5	21
1789	TC	30*38*7	7.5	21
1790	TC	30*38*8	7.5	21
1791	TC	30*38*10	8	23
1792	TC	30*40*4	7.5	23
1793	TC	30*40*5	7.5	23
1794	TC	30*40*6	7.5	23
1795	TC	30*40*7	7.5	23
1796	TC	30*40*8	7.5	23
1797	TC	30*40*10	7.5	25
1798	TC	30*40*12	8	27
1799	TC	30*40.5*10.5	7.5	27
1800	TC	30*41*5	7.5	23
1801	TC	30*41*7	7.5	23
1802	TC	30*41*10	8	28
1803	TC	30*41*10.5	8	28
1804	TC	30*42*4.5	7.5	24
1805	TC	30*42*5	7.5	24
1806	TC	30*42*6	7.5	24
1807	TC	30*42*6.5	7.5	24
1808	TC	30*42*7	7.5	24
1809	TC	30*42*8	7.5	24
1810	TC	30*42*9	7.5	24
1811	TC	30*42*10	7.5	25
1812	TC	30*42*10.5	7.7	24
1813	TC	30*42*11	8	26
1814	TC	30*42.1*8	7.5	26
1815	TC	30*43*4	8	25
1816	TC	30*43*7	8	25
1817	TC	30*43*8	8	25
1818	TC	30*43*8.5	8	29
1819	TC	30*43*9	8	28
1820	TC	30*43*10	8	28
1821	TC	30*43.5*7	8	30
1822	TC	30*44*5	8	26
1823	TC	30*44*7	7.5	26
1824	TC	30*44*8	8	26
1825	TC	30*44*9	8	26
1826	TC	30*44*10	8	27
1827	TC	30*44*10.5	8	30
1828	TC	30*44*11	8	30
1829	TC	30*45*5	8	27
1830	TC	30*45*6	8	27
1831	TC	30*45*7	7.5	27
1832	TC	30*45*8	7.5	27
1833	TC	30*45*10	8	29
1834	TC	30*45*12	9	32
1835	TC	30*45*13	9	35
1836	TC	30*46*6	9	28
1837	TC	30*46*7	8.5	28
1838	TC	30*46*8	8.5	28
1839	TC	30*46*10	8.5	29
1840	TC	30*46.8*6	8.5	30
1841	TC	30*47*4	8.5	29
1842	TC	30*47*5	8.5	29
1843	TC	30*47*6	8.5	29
1844	TC	30*47*7	8	29
1845	TC	30*47*8	8	29
1846	TC	30*47*9	8.5	29
1847	TC	30*47*10	8	30
1848	TC	30*47*12	9	33
1849	TC	30*48*7	9	30
1850	TC	30*48*8	9	30
1851	TC	30*48*10	9	31
1852	TC	30*48*12	9.5	33
1853	TC	30*49*7	9	31
1854	TC	30*49*8	10	31
1855	TC	30*49*10	10	32

现货油封 OIL SEAL IN STOCK

序号	类型	规格	丁腈橡胶单价RMB	氟橡胶单价RMB
NO.	TYPE	SPECIFICATION	NBR PRICE	FKM PRICE
1856	TC	30*50*4	8.5	32
1857	TC	30*50*5	8.5	32
1858	TC	30*50*7	8.5	32
1859	TC	30*50*8	9	32
1860	TC	30*50*10	9	32
1861	TC	30*50*11	9.5	36
1862	TC	30*50*12	9.8	35
1863	TC	30*50*12.5	10	38
1864	TC	30*51*7	9.5	33
1865	TC	30*51*10	9.5	35
1866	TC	30*52*5	9.5	33.5
1867	TC	30*52*6	9.5	33.5
1868	TC	30*52*7	9.5	33.5
1869	TC	30*52*7.40	9.5	33.5
1870	TC	30*52*8	9.5	33.5
1871	TC	30*52*10	9.5	33.5
1872	TC	30*52*11	10	33.5
1873	TC	30*52*12	10.5	33.5
1874	TC	30*52*10/12	10.5	33.5
1875	TC	30*52.4*10	9.5	33.5
1876	TC	30*53*10	10	35
1877	TC	30*53.3*10/14	10	38
1878	TC	30*53.5*10	10	35
1879	TC	30*54*6	11	35
1880	TC	30*54*7	11	35
1881	TC	30*54*8	11	35
1882	TC	30*54*9	11	35
1883	TC	30*54*10	10	36
1884	TC	30*55*5	10	40
1885	TC	30*55*7	10	40
1886	TC	30*55*8	10	40
1887	TC	30*55*9	10.8	43
1888	TC	30*55*10	10.1	43
1889	TC	30*55*11	11.2	48
1890	TC	30*55*12	11.2	45
1891	TC	30*55*23	25	65
1892	TC	30*56*7	11	43
1893	TC	30*56*7.5	11	43
1894	TC	30*56*8	11	43
1895	TC	30*56*10	11	45
1896	TC	30*56*12	11.6	46
1897	TC	30*57*9	11	45
1898	TC	30*57*10	11.5	46
1899	TC	30*57.15*10	12.5	47
1900	TC	30*58*8	11	45
1901	TC	30*58*9	11.5	48
1902	TC	30*58*10	11.5	45
1903	TC	30*58*12	12	48
1904	TC	30*60*7	11	46
1905	TC	30*60*8	11.5	46
1906	TC	30*60*10	12	49
1907	TC	30*60*12	12	51
1908	TC	30*62*5	11.5	42
1909	TC	30*62*7	11.5	48
1910	TC	30*62*8	11.5	48
1911	TC	30*62*10	11.7	49
1912	TC	30*62*11	12.5	53
1913	TC	30*62*12	13.5	57
1914	TC	30*62/63.5*10	13.5	57
1915	TC	30*65*8	13	51
1916	TC	30*65*10	13	52
1917	TC	30*65*12	14	57
1918	TC	30*65*9/11	14	55
1919	TC	30*66*10	15	51
1920	TC	30*68*6	13.5	53
1921	TC	30*68*8	13.5	53
1922	TC	30*68*10	13.5	53
1923	TC	30*68*12	15	62
1924	TC	30*70*8	13	58
1925	TC	30*70*10	14.5	58
1926	TC	30*70*11	15	67
1927	TC	30*70*12	15	63

序号	类型	规格	丁腈橡胶单价RMB	氟橡胶单价RMB
NO.	TYPE	SPECIFICATION	NBR PRICE	FKM PRICE
1928	TC	30*72*6.5	15	59
1929	TC	30*72*7	15	59
1930	TC	30*72*7.1	15	59
1931	TC	30*72*8	15.5	59
1932	TC	30*72*9	16	59
1933	TC	30*72*9.5	16	75.5
1934	TC	30*72*10	15	59
1935	TC	30*72*11	15	68
1936	TC	30*72*12	17	65
1937	TC	30*75*9	17	63
1938	TC	30*75*10	16.5	63
1939	TC	30*77*9	16.5	67
1940	TC	30*77*10	17.5	67
1941	TC	30*80*10	18	66
1942	TC	30*85*10	20	68
1943	TC	31*36*7	7	21
1944	TC	31*39*8	8	21
1945	TC	31*40*7	8	23
1946	TC	31*40*10	8	25
1947	TC	31*41*7	8	25
1948	TC	31*42*8	8	24
1949	TC	31*43*10	8	28
1950	TC	31*43*10.5	8	30
1951	TC	31*43*12.5	8	30
1952	TC	31*44*7	8	30
1953	TC	31*44*10	8	30
1954	TC	31*45*7	9	28
1955	TC	31*46*10	8.5	29
1956	TC	31*47*7	8	29
1957	TC	31*47*8	9	29
1958	TC	31*47*10	9	32
1959	TC	31*48*10	10	31
1960	TC	31*49*7	9.5	31
1961	TC	31*50*7	9	32
1962	TC	31*50*8	9	32
1963	TC	31*51*9	9.5	33
1964	TC	31*52*6	9.5	33.5
1965	TC	31*52*7	9.5	33.5
1966	TC	31*52*7	9.5	33.5
1967	TC	31*57*7	11	45
1968	TC	31*68*8	13.5	55
1969	TC	31.5*44.45*9.7	9	28
1970	TC	31.5*45*10	9	29
1971	TC	31.5*48*8	10	30
1972	TC	31.7*41.2*6.35	8	25
1973	TC	31.7*42.85*4.75	7.5	26
1974	TC	31.7*42.9*6.3	7.5	26
1975	TC	31.7*44.4*7.9	9	28
1976	TC	31.7*44.4*9.5	9	28
1977	TC	31.7*50.8*9.5	10	33
1978	TC	31.7*63.6*7.9	13	52
1979	TC	31.75*42.88*4.78	9	28
1980	TC	31.75*44.45*6.35	9	28
1981	TC	31.75*44.45*9.53	9	28
1982	TC	31.75*50.39*6.35	9	33
1983	TC	31.75*50.8*9.52S	10	38
1984	TC	31.8*62*7	13	48
1985	TC	32*38*5	7	23
1986	TC	32*38*8	7	23
1987	TC	32*38.5*8	7	23
1988	TC	32*39*7	8	21
1989	TC	32*40*5	8	23
1990	TC	32*40*6	8	23
1991	TC	32*40*7	7.5	23
1992	TC	32*40*8	8	23
1993	TC	32*40*10	8	26
1994	TC	32*41*10	9	27
1995	TC	32*42*4	7.5	24
1996	TC	32*42*5	8	24
1997	TC	32*42*6	7.5	24
1998	TC	32*42*7	7.5	24
1999	TC	32*42*8	8	24

现货油封 OIL SEAL IN STOCK

序号	类型	规格	丁腈橡胶单价RMB	氟橡胶单价RMB
NO.	TYPE	SPECIFICATION	NBR PRICE	FKM PRICE
2000	TC	32*42*9	7.5	24
2001	TC	32*42*10	7.5	24
2002	TC	32*43*5.5	7.5	29
2003	TC	32*43*7	7.5	25
2004	TC	32*43*8	7.5	25
2005	TC	32*43*10	7.5	25
2006	TC	32*43*10.5	8.5	29
2007	TC	32*43*12.5	9	30
2008	TC	32*44*5	8	26
2009	TC	32*44*7	7.5	26
2010	TC	32*44*8	7.5	26
2011	TC	32*44*9	8	26
2012	TC	32*44*10	7.5	30
2013	TC	32*44*10.5	8	30
2014	TC	32*44.4*6.3	9	28
2015	TC	32*45*5	8	27
2016	TC	32*45*6	8	27
2017	TC	32*45*7	7.5	27
2018	TC	32*45*8	8	27
2019	TC	32*45*9.5	8	27
2020	TC	32*45*10	8	27
2021	TC	32*46*6	8.5	28
2022	TC	32*46*7	8.5	28
2023	TC	32*46*8	8.5	28
2024	TC	32*46*10	8.5	30
2025	TC	32*47*6	9	29
2026	TC	32*47*7	8	29
2027	TC	32*47*8	8	29
2028	TC	32*47*9	8.5	30
2029	TC	32*47*10	8.5	30
2030	TC	32*47*8/9	9	38.4
2031	TC	32*48*6	10	30
2032	TC	32*48*6.5	10	30
2033	TC	32*48*7	9	30
2034	TC	32*48*8	9	30
2035	TC	32*48*10	9	31
2036	TC	32*49*7	9.5	31
2037	TC	32*49*9	9.5	31
2038	TC	32*50*7	9	32
2039	TC	32*50*8	9	32
2040	TC	32*50*8.5	10	32
2041	TC	32*50*10	9	32
2042	TC	32*50*11	9.8	34
2043	TC	32*50*12	9.8	35
2044	TC	32*50*13	12	38
2045	TC	32*50*9/11	10	46.6
2046	TC	32*51*7	9.5	33
2047	TC	32*51*8	9.5	33
2048	TC	32*52*5	9.5	33.5
2049	TC	32*52*6	9.5	33.5
2050	TC	32*52*7	9	33.5
2051	TC	32*52*8	9.5	33.5
2052	TC	32*52*9	9.5	33.5
2053	TC	32*52*9.5	9.5	33.5
2054	TC	32*52*10	9.5	33.5
2055	TC	32*52*11	9.6	33.5
2056	TC	32*52*12	10	33.5
2057	TC	32*52*10/12	10	51.9
2058	TC	32*53*7	9.5	34
2059	TC	32*54*7	10	35
2060	TC	32*54*8	10	35
2061	TC	32*54*10	11	36
2062	TC	32*55*7	11	40
2063	TC	32*55*8	10.2	40
2064	TC	32*55*10	10.8	44
2065	TC	32*55*11	11	45
2066	TC	32*55*12	12	48
2067	TC	32*56*8	11	43
2068	TC	32*56*10	11	45
2069	TC	32*56*12	12	52
2070	TC	32*57*7	11	45
2071	TC	32*58*7	11.5	45

序号	类型	规格	丁腈橡胶单价RMB	氟橡胶单价RMB
NO.	TYPE	SPECIFICATION	NBR PRICE	FKM PRICE
2072	TC	32*58*8	11	45
2073	TC	32*58*10	11.5	46
2074	TC	32*58*12	12.2	48
2075	TC	32*59*7	11.5	46
2076	TC	32*60*7	11	48
2077	TC	32*60*8	13	46
2078	TC	32*60*10	11.5	46
2079	TC	32*60*12	13	49
2080	TC	32*62*6	13	48
2081	TC	32*62*7	12	48
2082	TC	32*62*8	12	48
2083	TC	32*62*10	12.5	48
2084	TC	32*62*12	13	53
2085	TC	32*65*7.5	13	51
2086	TC	32*65*8	13	51
2087	TC	32*65*10	13	52
2088	TC	32*65*12	13	57
2089	TC	32*65*13	14	58
2090	TC	32*66*8	13	51
2091	TC	32*68*8	13	53
2092	TC	32*68*10	13	53
2093	TC	32*70*8	14	58
2094	TC	32*70*10	14	58
2095	TC	32*72*8	15	59
2096	TC	32*72*10	16	59
2097	TC	32*75*10	16.5	63
2098	TC	32.5*43*7	7.5	25
2099	TC	33*42*6	7.5	24
2100	TC	33*43*7	7.5	25
2101	TC	33*43*7	8	26
2102	TC	33*44*8	8	26
2103	TC	33*44*10	8	28
2104	TC	33*45*7	8	27
2105	TC	33*45*8	8	27
2106	TC	33*45*10	8	29
2107	TC	33*45*10.5	8	29
2108	TC	33*45*11	8	30
2109	TC	33*46*7	9	28
2110	TC	33*46*10	9	32
2111	TC	33*46*10.5	9	32
2112	TC	33*47*7	9	29
2113	TC	33*47*8	9	29
2114	TC	33*47*10	9	31
2115	TC	33*48*6	9	30
2116	TC	33*48*7	9	30
2117	TC	33*48*8	9	30
2118	TC	33*49*6	9.5	31
2119	TC	33*49*8	9.5	31
2120	TC	33*50*6	9.5	32
2121	TC	33*50*7	9.5	32
2122	TC	33*50*8	9.5	32
2123	TC	33*50*10	9.5	32
2124	TC	33*52*5	9.5	33.5
2125	TC	33*52*6	9.5	33.5
2126	TC	33*52*7	9.5	33.5
2127	TC	33*52*10	9.5	33.5
2128	TC	33*54*6	11	35
2129	TC	33*54*7	11	35
2130	TC	33*55*7	12	40
2131	TC	33*55*9.5	11	45
2132	TC	33*55*10	11	45
2133	TC	33*55*12	11.6	46
2134	TC	33*56*8	12	43
2135	TC	33*56*9	11	47
2136	TC	33*56*10	11	48
2137	TC	33*56*12	12	52
2138	TC	33*59*10	12	47
2139	TC	33*59*11/15	12	68.6
2140	TC	33*60*7	12	46
2141	TC	33*62*7	14	48
2142	TC	33*62*8	13	48
2143	TC	33*62*10	14	48

现货油封 OIL SEAL IN STOCK

序号	类型	规格	丁腈橡胶单价RMB	氟橡胶单价RMB
NO.	TYPE	SPECIFICATION	NBR PRICE	FKM PRICE
2144	TC	33*66*12	14	56
2145	TC	33*66*13	14	65
2146	TC	33*72*10	16	59
2147	TC	33.34*72.24*9.53	15.5	59
2148	TC	33.4*49.4*8.5	9.5	32
2149	TC	34*39*3	7.5	25
2150	TC	34*41*4	8	25
2151	TC	34*41*7	8	25
2152	TC	34*42*7	8	27
2153	TC	34*43*4.5	7.5	25
2154	TC	34*43*7	7.5	25
2155	TC	34*44*7	7.5	26
2156	TC	34*44*8	8	26
2157	TC	34*45*5	8	27
2158	TC	34*45*6	8	27
2159	TC	34*45*8	8	27
2160	TC	34*46*7	9	28
2161	TC	34*46*8	8.5	28
2162	TC	34*46*9	8.5	28
2163	TC	34*46*10	9	30
2164	TC	34*46*11	9	32
2165	TC	34*47*7	8.5	29
2166	TC	34*47*8	9	29
2167	TC	34*47*9	9	29
2168	TC	34*48*7	9	30
2169	TC	34*48*8	9	30
2170	TC	34*48*9	9	30
2171	TC	34*48*10	9	31
2172	TC	34*48*11	9	33
2173	TC	34*48*6.5/6.8	10	37.5
2174	TC	34*49*7	9.5	31
2175	TC	34*49*8	9.5	31
2176	TC	34*49*12.5	10	34
2177	TC	34*50*7	9.5	32
2178	TC	34*50*8	9.5	32
2179	TC	34*50*10	9.2	32
2180	TC	34*50*12	9.5	35
2181	TC	34*50.5*8	10	33
2182	TC	34*51*7	9.5	33
2183	TC	34*52*5	9.5	33.5
2184	TC	34*52*6	9.5	33.5
2185	TC	34*52*7	9.5	33.5
2186	TC	34*52*7.5	9.5	33.5
2187	TC	34*52*8	9.5	33.5
2188	TC	34*52*9	9.5	33.5
2189	TC	34*52*10	9.5	33.5
2190	TC	34*53*8	9.5	34
2191	TC	34*54*7	11	35
2192	TC	34*54*8	11	35
2193	TC	34*54*9	11	35
2194	TC	34*54*10	11	36
2195	TC	34*54*11	12	37
2196	TC	34*54*13	12	40
2197	TC	34*54*9/15.5	12	40
2198	TC	34*54.9*15.5	11	45
2199	TC	34*55*6	10	40
2200	TC	34*55*7	12	40
2201	TC	34*55*9	10.5	41
2202	TC	34*55*9.5	11	42
2203	TC	34*55*10	10.7	42
2204	TC	34*55*11	11	48
2205	TC	34*55*8/12	12	63
2206	TC	34*56*6	11	43
2207	TC	34*56*7	11	43
2208	TC	34*56*8	11	43
2209	TC	34*56*9	11	43
2210	TC	34*56*10	11	45
2211	TC	34*58*8	11.5	45
2212	TC	34*58*9	11.5	45
2213	TC	34*58*10	11.5	45
2214	TC	34*60*9	13	46
2215	TC	34*60*12	12	49

序号	类型	规格	丁腈橡胶单价RMB	氟橡胶单价RMB
NO.	TYPE	SPECIFICATION	NBR PRICE	FKM PRICE
2216	TC	34*62*6	11.18	48
2217	TC	34*62*7	11.5	48
2218	TC	34*62*8	12	48
2219	TC	34*62*10	13	51
2220	TC	34*62*12	13.5	54
2221	TC	34*62*14	13	65
2222	TC	34*63*9/15	15	75
2223	TC	34*66*10	14	56
2224	TC	34*68*7	13.5	53
2225	TC	34*70*10	14.5	58
2226	TC	34*72*10	16	59
2227	TC	34*72*11	16.5	65
2228	TC	34*74*11	17.5	72
2229	TC	34.3*44.2*4.7	8	28
2230	TC	34.9*46.4*6	8.5	30
2231	TC	34.9*53.9*9.5	10	35
2232	TC	34.9*54*11.13	11	40
2233	TC	34.92*47.6*6.3	8.5	29
2234	TC	35*40*6	8	27
2235	TC	35*41*8	8	27
2236	TC	35*42*4	8	27
2237	TC	35*42*7	8	24
2238	TC	35*42*8	8	24
2239	TC	35*42*10	8	26
2240	TC	35*43*7	7.5	25
2241	TC	35*43*8	7.5	25
2242	TC	35*44*7	8	26
2243	TC	35*44.45*7	9	28
2244	TC	35*45*4	7.5	27
2245	TC	35*45*5	7.5	27
2246	TC	35*45*6	7.5	27
2247	TC	35*45*7	9	28
2248	TC	35*45*8	7.5	27
2249	TC	35*45*10	8	29
2250	TC	35*45*12	8.5	30
2251	TC	35*46*7	8.5	28
2252	TC	35*46*8	8.5	28
2253	TC	35*46*10	9	30
2254	TC	35*47*5	9	29
2255	TC	35*47*6	9	29
2256	TC	35*47*7	8	29
2257	TC	35*47*8	8.5	29
2258	TC	35*47*10	8.5	30
2259	TC	35*47*12	9	33
2260	TC	35*47*7/10	10	36.2
2261	TC	35*47*7/7.5	10	33.5
2262	TC	35*47.1*10	9	33
2263	TC	35*47.5*9	9	33
2264	TC	35*48*6	9	30
2265	TC	35*48*7	9	30
2266	TC	35*48*8	9	30
2267	TC	35*48*9	10	30
2268	TC	35*48*10	9	31
2269	TC	35*48*11	10	33
2270	TC	35*48*12.5	12	35
2271	TC	35*49*6	9	31
2272	TC	35*49*7	9	31
2273	TC	35*49*8	9	31
2274	TC	35*49*10	9	32
2275	TC	35*49*12.5	9.5	34
2276	TC	35*49.2*12	9.5	34
2277	TC	35*49.5*7	9.5	32
2278	TC	35*50*6	9.5	32
2279	TC	35*50*7	8.5	32
2280	TC	35*50*8	8.5	32
2281	TC	35*50*9	9	32
2282	TC	35*50*10	8.5	32
2283	TC	35*50*11	9.5	35
2284	TC	35*50*12	9.5	35
2285	TC	35*51*6	9.5	33
2286	TC	35*51*7	9.5	33
2287	TC	35*51*8	9.5	33

现货油封 OIL SEAL IN STOCK

序号	类型	规格	丁腈橡胶单价RMB	氟橡胶单价RMB
NO.	TYPE	SPECIFICATION	NBR PRICE	FKM PRICE
2288	TC	35*51*10	9.5	35
2289	TC	35*52*4.5	9.5	33.5
2290	TC	35*52*5	9.5	33.5
2291	TC	35*52*6	9.5	33.5
2292	TC	35*52*7	9	33.5
2293	TC	35*52*7.5	9	33.5
2294	TC	35*52*8	9	33.5
2295	TC	35*52*9	9.5	33.5
2296	TC	35*52*9.5	9.5	33.5
2297	TC	35*52*10	9.5	33.5
2298	TC	35*52*11	9.5	33.5
2299	TC	35*52*12	9.6	33.5
2300	TC	35*52*16	11	33.5
2301	TC	35*52.1*10	9.5	33.5
2302	TC	35*52.1*12	9.5	33.5
2303	TC	35*52.3*9.5	11	33.5
2304	TC	35*53*7	9.5	34
2305	TC	35*53.95*11	10	45.9
2306	TC	35*54*7	11	35
2307	TC	35*54*8	10	35
2308	TC	35*54*9	10	35
2309	TC	35*54*10	10	36
2310	TC	35*54*11	11	38
2311	TC	35*54*12	11	38
2312	TC	35*54*12.5	11	40
2313	TC	35*55*7	10	40
2314	TC	35*55*8	10	40
2315	TC	35*55*9	11	42
2316	TC	35*55*9.5	11	43
2317	TC	35*55*10	10	43
2318	TC	35*55*11	11.5	45
2319	TC	35*55*12	10.8	46
2320	TC	35*56*5.8	10.5	43
2321	TC	35*56*6	10.5	43
2322	TC	35*56*7	10.5	43
2323	TC	35*56*8	10.5	43
2324	TC	35*56*10	10.2	45
2325	TC	35*56*12	10.8	46
2326	TC	35*57*6	11	45
2327	TC	35*57*8	11	45
2328	TC	35*57*9	11	45
2329	TC	35*57*10	11.5	48
2330	TC	35*58*7	11.5	45
2331	TC	35*58*8	11.5	45
2332	TC	35*58*10	11	45
2333	TC	35*58*12	12.2	49
2334	TC	35*58*15	14	55
2335	TC	35*59*12	12	49
2336	TC	35*60*7	12	46
2337	TC	35*60*8	11.5	46
2338	TC	35*60*9	13	46
2339	TC	35*60*10	11.5	46
2340	TC	35*60*12	11.6	51
2341	TC	35*60*17	12	62
2342	TC	35*60.30*9.50	13	47
2343	TC	35*61*7	13	48
2344	TC	35*62*5	11.5	48
2345	TC	35*62*6	11.5	48
2346	TC	35*62*7	11.5	48
2347	TC	35*62*8	11.5	48
2348	TC	35*62*9	12	48
2349	TC	35*62*9.5	13	48
2350	TC	35*62*10	11.5	50
2351	TC	35*62*12	12.5	53
2352	TC	35*63*10	13	49
2353	TC	35*63.3*9	13	52
2354	TC	35*63.5*12.5	14	65
2355	TC	35*64*8	13	50
2356	TC	35*64*10	13	52
2357	TC	35*64*12	13.5	62
2358	TC	35*64*13	13	72
2359	TC	35*65*7	13	51

序号	类型	规格	丁腈橡胶单价RMB	氟橡胶单价RMB
NO.	TYPE	SPECIFICATION	NBR PRICE	FKM PRICE
2360	TC	35*65*8	12	51
2361	TC	35*65*9	12.5	54
2362	TC	35*65*10	12	54
2363	TC	35*65*11	13.5	57
2364	TC	35*65*12	13.5	57
2365	TC	35*65*13	14	65
2366	TC	35*66*7	13.5	51
2367	TC	35*66*10	14	54
2368	TC	35*67*20	20	85
2369	TC	35*68*7	13.5	53
2370	TC	35*68*8	13	53
2371	TC	35*68*10	13.5	53
2372	TC	35*70*7	14	55
2373	TC	35*70*8	14	58
2374	TC	35*70*10	14	61
2375	TC	35*70*12	15	62
2376	TC	35*72*7	14.3	59
2377	TC	35*72*8	14.2	59
2378	TC	35*72*9	15.5	59
2379	TC	35*72*10	14.7	59
2380	TC	35*72*12	17	67
2381	TC	35*72*13	18	70
2382	TC	35*73*7	14	63
2383	TC	35*73*10	16.5	63
2384	TC	35*72/73.5*10	16.5	63
2385	TC	35*75*6	16	58
2386	TC	35*75*8	16	63
2387	TC	35*75*9	17	63
2388	TC	35*75*10	17.5	65
2389	TC	35*75*12	18	68
2390	TC	35*77*10	17	67
2391	TC	35*78*8	16	64
2392	TC	35*78*10	18	70
2393	TC	35*80*7	17	66
2394	TC	35*80*8	17	66
2395	TC	35*80*10	17.2	68
2396	TC	35*80*11	15.5	68
2397	TC	35*80*12	18.5	69
2398	TC	35*81*10	19	75
2399	TC	35*82*7	17	67
2400	TC	35*82*10	18.5	67
2401	TC	35*90*10	21	70
2402	TC	35.5*49*7	9.5	31
2403	TC	36*43*8	7.5	25
2404	TC	36*44*5	8	26
2405	TC	36*44*10	8	28
2406	TC	36*45*7	8	27
2407	TC	36*46*6	9	28
2408	TC	36*46*7	8	28
2409	TC	36*46*8	8	28
2410	TC	36*46*9	8.5	28
2411	TC	36*47*7	8.5	29
2412	TC	36*48*6	10	30
2413	TC	36*48*7	10	30
2414	TC	36*48*8	9	30
2415	TC	36*48*10	9	31
2416	TC	36*48*10.5	10	33
2417	TC	36*48*11	10	34
2418	TC	36*49*7	9.5	31
2419	TC	36*49*8	10	32
2420	TC	36*49*10	10	32
2421	TC	36*50*5	10	32
2422	TC	36*50*7	9	32
2423	TC	36*50*8	10	32
2424	TC	36*50*10	9	32
2425	TC	36*50.5*8	10	33
2426	TC	36*51*7	9.5	33
2427	TC	36*51*8	9.5	33
2428	TC	36*52*7	9.5	33.5
2429	TC	36*52*8	9.5	33.5
2430	TC	36*52*9	9.5	33.5
2431	TC	36*52*10	9.5	33.5

现货油封 OIL SEAL IN STOCK

序号	类型	规格	丁腈橡胶单价RMB	氟橡胶单价RMB
NO.	TYPE	SPECIFICATION	NBR PRICE	FKM PRICE
2432	TC	36*52*11	9.5	33.5
2433	TC	36*52*12	9.8	33.5
2434	TC	36*53*7	10	34
2435	TC	36*53*11	9.8	38
2436	TC	36*54*7	10	35
2437	TC	36*54*7.5	10	35
2438	TC	36*54*8	10	35
2439	TC	36*54*10	10	36
2440	TC	36*54*11	10	38
2441	TC	36*55*7	10	40
2442	TC	36*55*8	10	40
2443	TC	36*55*10	10.8	43
2444	TC	36*55*12	11.5	50
2445	TC	36*56*7	11	43
2446	TC	36*56*8	11	43
2447	TC	36*56*10	11	43
2448	TC	36*56*12	11.6	51
2449	TC	36*56.5*10	12	45
2450	TC	36*57*10	11.5	49
2451	TC	36*58*8	11.5	45
2452	TC	36*58*10	11.5	45
2453	TC	36*58*12	12	48
2454	TC	36*59*12	12	49
2455	TC	36*60*10	13	46
2456	TC	36*60*12	13	56
2457	TC	36*62*7	13	48
2458	TC	36*62*10	13	50
2459	TC	36*62*14	14	56
2460	TC	36*65*7.5	12	51
2461	TC	36*66*10	13.5	51
2462	TC	36*68*8	13.5	53
2463	TC	36*68*10	14	55
2464	TC	36*70*8	14	58
2465	TC	36*72*8	15	59
2466	TC	36*77*10	17	67
2467	TC	36*98*7	35	75
2468	TC	36.5*50.5*6	10	33
2469	TC	36.5*50.5*7	10	33
2470	TC	36.5*50.8*7.925	10	33
2471	TC	36.5*52.3*8	11	33.5
2472	TC	36.5*57*10	11	49
2473	TC	36.5*60.3*9.5	13	47
2474	TC	37*44*5	8	26
2475	TC	37*45*7	8	27
2476	TC	37*47*7	8.5	30
2477	TC	37*47*10	8.5	30
2478	TC	37*47.5*5.2	8.5	29
2479	TC	37*48*6	10	30
2480	TC	37*48*7	10	30
2481	TC	37*49*7	9.5	31
2482	TC	37*49*8	9.5	31
2483	TC	37*49*11	10	32
2484	TC	37*50*6	9	32
2485	TC	37*50*6.5	10	32
2486	TC	37*50*7	9	32
2487	TC	37*50*10	11	32
2488	TC	37*50*10.5	9.5	34
2489	TC	37*50*11	9.5	35
2490	TC	37*51*12	9.5	36
2491	TC	37*52*7	9.5	33.5
2492	TC	37*52*8	9.5	33.5
2493	TC	37*52*10	10	33.5
2494	TC	37*52*14.5	10	33.5
2495	TC	37*53*7	9.5	34
2496	TC	37*55*7	10	42
2497	TC	37*55*8	11	40
2498	TC	37*55*9	11	40
2499	TC	37*56*10	11	45
2500	TC	37*57*8	11	45
2501	TC	37*57*10	11.5	45
2502	TC	37*58*7	11.5	45
2503	TC	37*58*10	11.5	45

序号	类型	规格	丁腈橡胶单价RMB	氟橡胶单价RMB
NO.	TYPE	SPECIFICATION	NBR PRICE	FKM PRICE
2504	TC	37*58*13	12.2	50
2505	TC	37*59*7	11	46
2506	TC	37*59*11	12	51
2507	TC	37*60*6.5	12	46
2508	TC	37*60*7	12	46
2509	TC	37*60*8	12	46
2510	TC	37*60*10	12	46
2511	TC	37*61*10	13	51
2512	TC	37*62*7	13	48
2513	TC	37*62*8	13	48
2514	TC	37*62*10	13	48
2515	TC	37*62*12.5	15	60
2516	TC	37*63.5*8	13	52
2517	TC	37*64*13	13	72
2518	TC	37*65*12	13.5	56
2519	TC	37*66*9.5	13	51
2520	TC	37*66*10	13.5	51
2521	TC	37*73*8	15.5	63
2522	TC	37*76*8	16	63
2523	TC	37*76*9.5	17	63
2524	TC	37*76*10	17.5	63
2525	TC	37*76*9.5/12	17	91.6
2526	TC	37.4*62*10	15	49
2527	TC	37.5*47*5	8.5	29
2528	TC	38*44*10	8	28
2529	TC	38*45*7	8	27
2530	TC	38*47*5	8.5	29
2531	TC	38*47*6	8.5	29
2532	TC	38*47*7	8.5	29
2533	TC	38*47*10	8.5	30
2534	TC	38*48*6	9.5	30
2535	TC	38*48*7	9	30
2536	TC	38*48*8	9	30
2537	TC	38*48*10	9	31
2538	TC	38*49*8	9.5	31
2539	TC	38*49*9	10	31
2540	TC	38*49*8/12	10	41.9
2541	TC	38*49.5*8	9.5	32
2542	TC	38*50*6	9	32
2543	TC	38*50*7	9	32
2544	TC	38*50*8	9	32
2545	TC	38*50*10	9	32
2546	TC	38*50*11	9	34
2547	TC	38*50*12	9	35
2548	TC	38*50.5*8	10	33
2549	TC	38*51*7	9.5	33
2550	TC	38*51*8	9.5	33
2551	TC	38*52*6	9.5	33.5
2552	TC	38*52*7	9.5	33.5
2553	TC	38*52*8	9.5	33.5
2554	TC	38*52*8.5	9.5	33.5
2555	TC	38*52*9	9.5	33.5
2556	TC	38*52*9.5	9.5	33.5
2557	TC	38*52*10	9.5	33.5
2558	TC	38*52*11	9.5	33.5
2559	TC	38*52*12	10	33.5
2560	TC	38*53*7	9.5	34
2561	TC	38*53*8	9.5	34
2562	TC	38*54*7	10	35
2563	TC	38*54*8	10	35
2564	TC	38*54*10	10	36
2565	TC	38*55*5	11	40
2566	TC	38*55*6	10	40
2567	TC	38*55*7	10	40
2568	TC	38*55*8	10	40
2569	TC	38*55*8.5	11	40
2570	TC	38*55*9	11	40
2571	TC	38*55*10	10.8	43
2572	TC	38*55*12	11	47
2573	TC	38*56*6	11	43
2574	TC	38*56*7	11	43
2575	TC	38*56*8	10.5	43

现货油封 OIL SEAL IN STOCK

序号	类型	规格	丁腈橡胶单价RMB	氟橡胶单价RMB
NO.	TYPE	SPECIFICATION	NBR PRICE	FKM PRICE
2576	TC	38*56*10	10.5	45
2577	TC	38*56*12	11	45
2578	TC	38*57*7	12.5	45
2579	TC	38*57*9	11	45
2580	TC	38*57*10	11	46
2581	TC	38*58*7	11	45
2582	TC	38*58*8	11	45
2583	TC	38*58*8.5	11	45
2584	TC	38*58*9	11	45
2585	TC	38*58*10	10.5	46
2586	TC	38*58*11	11.7	46
2587	TC	38*58*12	12.1	49
2588	TC	38*59*10	11.5	46
2589	TC	38*60*7	13	46
2590	TC	38*60*8	12	46
2591	TC	38*60*10	12	49
2592	TC	38*60*12	12.5	51
2593	TC	38*60.5*12	13.5	50
2594	TC	38*60.5*12.5	14	50
2595	TC	38*62*7	11.5	48
2596	TC	38*62*8	11.5	48
2597	TC	38*62*10	11.5	51
2598	TC	38*62*12	13	52
2599	TC	38*63*9	13	49
2600	TC	38*63.5*10	13	52
2601	TC	38*63.5*12	13	72
2602	TC	38*63.6*8	13	52
2603	TC	38*63.70*8	13	52
2604	TC	38*64*10	13	52
2605	TC	38*64*13	13	72
2606	TC	38*65*8	13	51
2607	TC	38*65*9	13	51
2608	TC	38*65*10	13	54
2609	TC	38*65*12	13.5	56
2610	TC	38*66*10	13.5	51
2611	TC	38*67*12/20	15	80
2612	TC	38*68*8	13	53
2613	TC	38*68*10	14	55
2614	TC	38*69*10	14	60
2615	TC	38*70*8	14	58
2616	TC	38*70*10	14	58
2617	TC	38*70*12	14.9	62
2618	TC	38*72*8	15	59
2619	TC	38*72*10	17	59
2620	TC	38*72*11	17	61
2621	TC	38*72*12	17	67
2622	TC	38*73*8	15	63
2623	TC	38*74*8	16	63
2624	TC	38*74*10	17	63
2625	TC	38*74*11	17	67
2626	TC	38*74*11/18	20	106
2627	TC	38*75*10	17	63
2628	TC	38*80*7	16.3	66
2629	TC	38*80*8	16.4	66
2630	TC	38*80*10	18	69
2631	TC	38*80*12	18	69
2632	TC	38*82*7	16.5	67
2633	TC	38*82*10	18.5	67
2634	TC	38*85*10	19.5	68
2635	TC	38*85*11	20	68
2636	TC	38.1*50.8*6.35	10	33
2637	TC	38.1*53.9*7.9	10	35
2638	TC	38.10*57.15*7.92	12.5	45
2639	TC	38.1*57.2*9.5	12.5	45
2640	TC	38.1*57.2*12.7	12.5	50
2641	TC	38.1*63.5*9.5	14	52
2642	TC	38.5*55*11	11.5	47
2643	TC	38.5*58*8.5	11	45
2644	TC	38.5*62*11	12	52
2645	TC	39*45*7	8	27
2646	TC	39*50*8	10	32
2647	TC	39*51*7.5	9.5	33

序号	类型	规格	丁腈橡胶单价RMB	氟橡胶单价RMB
NO.	TYPE	SPECIFICATION	NBR PRICE	FKM PRICE
2648	TC	39*52*6	9.5	33.5
2649	TC	39*52*7	9.5	33.5
2650	TC	39*52*8	9.5	33.5
2651	TC	39*52*10	9.5	33.5
2652	TC	39*52*8/10.5	10	45.6
2653	TC	39*54*10	11	36
2654	TC	39*55*9	11	41
2655	TC	39*55*10	11	41
2656	TC	39*56*7	11	43
2657	TC	39*59*8	11.5	46
2658	TC	39*60*9	12	46
2659	TC	39*60*10	12	46
2660	TC	39*62*10	12.5	49
2661	TC	39*62*12	13	53
2662	TC	39*63.5*8	14	52
2663	TC	39*65*8	13	51
2664	TC	39*66*12	14	65
2665	TC	39.4*63.6*12.7	13	72
2666	TC	39.5*52*10/14	11	53.5
2667	TC	39.5*60*10	12	46
2668	TC	39.6*52*11	10	33.5
2669	TC	40*47*4	8.5	29
2670	TC	40*47*5	8.5	29
2671	TC	40*47*5.5	8.5	29
2672	TC	40*48*7	9	30
2673	TC	40*49*6	10	31
2674	TC	40*50*4	9	32
2675	TC	40*50*5	9	32
2676	TC	40*50*6	9	32
2677	TC	40*50*6.5	10	32
2678	TC	40*50*7	8.5	32
2679	TC	40*50*8	9	32
2680	TC	40*50*10	9	32
2681	TC	40*50*12	9.5	35
2682	TC	40*52*4	9.5	33.5
2683	TC	40*52*5	9.5	33.5
2684	TC	40*52*6	9.5	33.5
2685	TC	40*52*7	9	33.5
2686	TC	40*52*7.4	9.5	33.5
2687	TC	40*52*8	9.5	33.5
2688	TC	40*52*9	9.5	33.5
2689	TC	40*52*10	9.5	33.5
2690	TC	40*52*11	9.5	33.5
2691	TC	40*52*12	9.5	33.5
2692	TC	40*52*13	9.5	33.5
2693	TC	40*52*14	9.5	33.5
2694	TC	40*52.5*6	9.5	33.5
2695	TC	40*53*6	9.5	34
2696	TC	40*53*6.5	9.5	34
2697	TC	40*53*7	9.5	34
2698	TC	40*53*8	9.5	34
2699	TC	40*54*5	10	35
2700	TC	40*54*5.5	10	35
2701	TC	40*54*6	10	35
2702	TC	40*54*7	10	35
2703	TC	40*54*8	10	35
2704	TC	40*54*10	10	36
2705	TC	40*54*10.5	10	38
2706	TC	40*55*5	11	40
2707	TC	40*55*6	11	40
2708	TC	40*55*7	10	40
2709	TC	40*55*8	10	40
2710	TC	40*55*9	10.3	40
2711	TC	40*55*10	10	41
2712	TC	40*55*12	11	44
2713	TC	40*55.5*4	10	42
2714	TC	40*56*6	11	43
2715	TC	40*56*7	10.5	43
2716	TC	40*56*8	10.5	43
2717	TC	40*56*9	11	43
2718	TC	40*56*10	10.8	45
2719	TC	40*56*12	11.6	47

现货油封 OIL SEAL IN STOCK

序号	类型	规格	丁腈橡胶单价RMB	氟橡胶单价RMB
NO.	TYPE	SPECIFICATION	NBR PRICE	FKM PRICE
2720	TC	40*57*7	11	45
2721	TC	40*57*8	11	45
2722	TC	40*57*10	11	45
2723	TC	40*57.15*10	12.5	47
2724	TC	40*58*3	11	54
2725	TC	40*58*6	10.5	45
2726	TC	40*58*7	10.5	45
2727	TC	40*58*8	10.5	45
2728	TC	40*58*9	11	45
2729	TC	40*58*10	10.5	46
2730	TC	40*58*12	12.1	49
2731	TC	40*59*10	11.5	50
2732	TC	40*60*5	13	49.5
2733	TC	40*60*6	13	42
2734	TC	40*60*7	12	43
2735	TC	40*60*8	11.5	46
2736	TC	40*60*9	12	46
2737	TC	40*60*10	11.5	46
2738	TC	40*60*12	11.5	51
2739	TC	40*60*18.5	13	70
2740	TC	40*60*8/10	12	71.2
2741	TC	40*62*5	11.5	42
2742	TC	40*62*6	11.5	45
2743	TC	40*62*7	11.5	48
2744	TC	40*62*8	11.5	48
2745	TC	40*62*9	12	48
2746	TC	40*62*10	11.5	51
2747	TC	40*62*11	13	55
2748	TC	40*62*11.5	13	55
2749	TC	40*62*12	12.2	55
2750	TC	40*62.1*10	13	60
2751	TC	40*63*7	11.5	49
2752	TC	40*63*8	12	49
2753	TC	40*63*10	12.5	49
2754	TC	40*63*12	13.8	53
2755	TC	40*63.5*10	13	52
2756	TC	40*64*4	13	45
2757	TC	40*64*7	13	50
2758	TC	40*64*8	13	50
2759	TC	40*64*10	13	50
2760	TC	40*64*12	13.5	54
2761	TC	40*65*5	13	51
2762	TC	40*65*7	13	51
2763	TC	40*65*8	12	51
2764	TC	40*65*9	13	51
2765	TC	40*65*10	12	51
2766	TC	40*65*11	13	57
2767	TC	40*65*12	12.8	57
2768	TC	40*66*7	13	51
2769	TC	40*66*10	13	60
2770	TC	40*66*12	14	65
2771	TC	40*67*10	13.5	53
2772	TC	40*68*4	13	53
2773	TC	40*68*6	13	53
2774	TC	40*68*7	13	53
2775	TC	40*68*8	13	53
2776	TC	40*68*10	12.6	53
2777	TC	40*68*11	13	58
2778	TC	40*68*12	14.2	60
2779	TC	40*68*13	15	70
2780	TC	40*70*7	14	58
2781	TC	40*70*8	13.5	58
2782	TC	40*70*9	14	58
2783	TC	40*70*10	13.5	58
2784	TC	40*70*12	13.8	62
2785	TC	40*70.5*10	14	58
2786	TC	40*72*5.12	15	55
2787	TC	40*72*7	14	59
2788	TC	40*72*8	14.8	59
2789	TC	40*72*10	14.5	59
2790	TC	40*72*11	16	59
2791	TC	40*72*12	15.5	55

序号	类型	规格	丁腈橡胶单价RMB	氟橡胶单价RMB
NO.	TYPE	SPECIFICATION	NBR PRICE	FKM PRICE
2792	TC	40*74*10	16	63
2793	TC	40*74*12	18	68
2794	TC	40*75*8	16.5	63
2795	TC	40*75*10	17	63
2796	TC	40*75*12	17.5	68
2797	TC	40*75*21	30	85
2798	TC	40*76*8	15.4	63
2799	TC	40*76*10	16	63
2800	TC	40*78*7	15.5	64
2801	TC	40*80*7	16.3	66
2802	TC	40*80*8	16.4	66
2803	TC	40*80*9	17.5	66
2804	TC	40*80*10	16.4	69
2805	TC	40*80*12	17.4	73
2806	TC	40*80*13	19.5	75
2807	TC	40*85*8	18	68
2808	TC	40*85*10	20	68
2809	TC	40*85*12	20	75
2810	TC	40*86*10	19.6	74
2811	TC	40*90*8	20	70
2812	TC	40*90*10	20	76
2813	TC	40*90*12	21.6	85
2814	TC	40*92*10	24	82
2815	TC	40.2*44*6.15	8	28
2816	TC	41*51*6	9.5	33
2817	TC	41*53*6	10	34
2818	TC	41*53*7	9.5	34
2819	TC	41*53*8	9.5	34
2820	TC	41*53*10.5	9.5	35
2821	TC	41*53*11	9.5	35
2822	TC	41*54*7	10	35
2823	TC	41*54*8	10	35
2824	TC	41*54*11	10	36
2825	TC	41*54*12	10	38
2826	TC	41*55*6	10	40
2827	TC	41*55*7	11	40
2828	TC	41*55*7.6	11	40
2829	TC	41*55*9	11	42
2830	TC	41*56*7	10.5	43
2831	TC	41*56*9	11	45
2832	TC	41*56*10	11	46
2833	TC	41*59*10	11.5	50
2834	TC	41*61*10	13	51
2835	TC	41*61*8/13	14	67.6
2836	TC	41*64*10	13	55
2837	TC	41*64.5*12	13.5	72
2838	TC	41.2*63.5*12.7	13	72
2839	TC	41.27*63.5*12.7	13	72
2840	TC	41.275*60.325*9.525	14	47
2841	TC	41.28*53.98*6.35	9.5	35
2842	TC	41.28*63.5*9.53	13	52
2843	TC	41.3*69.85*9.53	14	60
2844	TC	41.5*57.5*8	12.5	45
2845	TC	42*50*7	9	32
2846	TC	42*50*8	9	32
2847	TC	42*50*10	9	32
2848	TC	42*51*7	10.5	33
2849	TC	42*52*4	9.5	33.5
2850	TC	42*52*7	9.5	33.5
2851	TC	42*52*8	9.5	33.5
2852	TC	42*52*10	9.5	33.5
2853	TC	42*52*12	9.5	33.5
2854	TC	42*53*5	9.5	34
2855	TC	42*53*7	9.5	34
2856	TC	42*53*7.5	9.5	34
2857	TC	42*53*8	9.5	34
2858	TC	42*54*7	11	35
2859	TC	42*54*8	11	35
2860	TC	42*54*10	11	36
2861	TC	42*54.5*6	11	35
2862	TC	42*55*6	11	40
2863	TC	42*55*7	10	40

现货油封 OIL SEAL IN STOCK

序号	类型	规格	丁腈橡胶单价RMB	氟橡胶单价RMB
NO.	TYPE	SPECIFICATION	NBR PRICE	FKM PRICE
2864	TC	42*55*8	10	40
2865	TC	42*55*9	11	42
2866	TC	42*55*10	10.7	45
2867	TC	42*55*12	11	48
2868	TC	42*56*7	10	43
2869	TC	42*56*8	11	43
2870	TC	42*56*9	11	43
2871	TC	42*56*10	10.7	43
2872	TC	42*57*7	11	45
2873	TC	42*57*10	11	45
2874	TC	42*58*7	11	45
2875	TC	42*58*8	11	45
2876	TC	42*58*10	11	46
2877	TC	42*58*12	12.1	49
2878	TC	42*59*7	11.5	46
2879	TC	42*59*10	11.5	46
2880	TC	42*60*6	13	46
2881	TC	42*60*7	12	46
2882	TC	42*60*8	12	46
2883	TC	42*60*9	11.5	46
2884	TC	42*60*10	11.5	46
2885	TC	42*60*12	12	49
2886	TC	42*62*7	11.5	48
2887	TC	42*62*8	11.5	48
2888	TC	42*62*9	13	48
2889	TC	42*62*10	11.5	51
2890	TC	42*62*12	12.5	51
2891	TC	42*62*17	22	74.5
2892	TC	42*63*7	13	49
2893	TC	42*63*9	13	49
2894	TC	42*64*7	13	50
2895	TC	42*64*8	13	50
2896	TC	42*64*9	13	52
2897	TC	42*64*10	13	52
2898	TC	42*64*12	13.5	55
2899	TC	42*65*7	13	51
2900	TC	42*65*8	12	51
2901	TC	42*65*9	13	51
2902	TC	42*65*10	12.8	51
2903	TC	42*65*12	13.5	57
2904	TC	42*66*7	13	51
2905	TC	42*66*8	13	53
2906	TC	42*66*10	13	53
2907	TC	42*67*8	13	53
2908	TC	42*67*10	13	53
2909	TC	42*67*17.6	13	80
2910	TC	42*68*7	13	53
2911	TC	42*68*8	13	53
2912	TC	42*68*10	13.5	53
2913	TC	42*68*12	14	56
2914	TC	42*70*8	13.5	58
2915	TC	42*70*10	13.8	58
2916	TC	42*70*12	14.5	62
2917	TC	42*72*5.12	14	59
2918	TC	42*72*7	14.8	59
2919	TC	42*72*8	14.8	59
2920	TC	42*72*10	16	59
2921	TC	42*72*12	17	59
2922	TC	42*72.8*12	14	63
2923	TC	42*74*10	16.5	63
2924	TC	42*75*8	16	63
2925	TC	42*75*10	16.5	63
2926	TC	42*75*12	17.5	67
2927	TC	42*76*8	15.4	63
2928	TC	42*76*10	17	63
2929	TC	42*76*12	17.5	65
2930	TC	42*78*9.5	17	64
2931	TC	42*78*10	17.5	64
2932	TC	42*80*8	16.3	66
2933	TC	42*80*9	15.5	66
2934	TC	42*80*10	18	69
2935	TC	42*82*10.5	18.5	69

序号	类型	规格	丁腈橡胶单价RMB	氟橡胶单价RMB
NO.	TYPE	SPECIFICATION	NBR PRICE	FKM PRICE
2936	TC	42*85*8	18.5	68
2937	TC	42*85*10	19.5	68
2938	TC	42*88*10	20	73
2939	TC	42*94*10	24	83
2940	TC	42.05*63.05*12.7	13	72
2941	TC	42.5*54.5*6	11	35
2942	TC	42.8*66.7*9.5	13	53
2943	TC	43*50*7	10	32
2944	TC	43*53*11	9.5	34
2945	TC	43*54*6	10	35
2946	TC	43*54*7.5	10	35
2947	TC	43*54*11	10	36
2948	TC	43*55*6	11	40
2949	TC	43*55*7	10	40
2950	TC	43*55*8	11	40
2951	TC	43*55*9	11	40
2952	TC	43*55*10	11	45
2953	TC	43*55*11	11	46
2954	TC	43*56*8	11	43
2955	TC	43*57*11	11	50
2956	TC	43*58*7	11.5	45
2957	TC	43*58*8	11.5	45
2958	TC	43*58*11	11.5	49
2959	TC	43*60*7	13	46
2960	TC	43*60*10	13	46
2961	TC	43*62*7	13	48
2962	TC	43*62*8	13	48
2963	TC	43*62*10	13	51
2964	TC	43*62*12	13	52
2965	TC	43*63*10	13	49
2966	TC	43*65*8	13	51
2967	TC	43*65*10	13	51
2968	TC	43*66*10	13.5	53
2969	TC	43*73*10	16.5	63
2970	TC	43*75*10	16.5	63
2971	TC	43*77*12.5	18.5	67
2972	TC	43*79*10	17.5	64
2973	TC	43.6*60.3*9.5	13	47
2974	TC	44*52*7	9.5	33.5
2975	TC	44*54*4.5	11	35
2976	TC	44*54*5	11	35
2977	TC	44*54*7	11	35
2978	TC	44*54*7.5	11	35
2979	TC	44*54.9*7	11	40
2980	TC	44*55*5.5	11	40
2981	TC	44*55*7	10	40
2982	TC	44*56*10	11	43
2983	TC	44*57*8	11	45
2984	TC	44*57*9	11	45
2985	TC	44*58*4	11.5	45
2986	TC	44*58*8	11	45
2987	TC	44*58*10	11	48
2988	TC	44*59*8	11.5	43
2989	TC	44*60*7	12	46
2990	TC	44*60*8	13	46
2991	TC	44*60*9	13	46
2992	TC	44*60*10	12	46
2993	TC	44*61*10	14	51
2994	TC	44*62*7	13	48
2995	TC	44*62*8	13	48
2996	TC	44*62*9	13	48
2997	TC	44*62*10	12	48
2998	TC	44*62*12	13	53
2999	TC	44*62*7/12.5	13	72.5
3000	TC	44*63*7	13	45
3001	TC	44*63.5*9	14	52
3002	TC	44*63.5*10	14	52
3003	TC	44*64*5	12	45
3004	TC	44*64*8	12	50
3005	TC	44*64*9	12	50
3006	TC	44*65*8	13	51
3007	TC	44*65*10	13	51

现货油封 OIL SEAL IN STOCK

序号	类型	规格	丁腈橡胶单价RMB	氟橡胶单价RMB
NO.	TYPE	SPECIFICATION	NBR PRICE	FKM PRICE
3008	TC	44*65*11	13	55
3009	TC	44*67*10	13.5	55
3010	TC	44*68*8	13	53
3011	TC	44*68*13	15	68
3012	TC	44*70*10	14	62
3013	TC	44*70*12	14	62
3014	TC	44*72*8	14	59
3015	TC	44*72*10	15	59
3016	TC	44*76*9.5	17.5	63
3017	TC	44*76.1*12.7	16.5	96.8
3018	TC	44*80*10	18	69
3019	TC	44*88*8	18	73
3020	TC	44*92*10	24	78
3021	TC	44.4*63*7.92	13	45
3022	TC	44.4*63.5*9.5	13	52
3023	TC	44.4*69.8*9.5	14	60
3024	TC	44.4*69.8*12.7	14	63
3025	TC	44.4*80.9*12.7	16	75
3026	TC	44.45*57.15*7.92	12.5	45
3027	TC	44.45*57.15*9.52	12.5	47
3028	TC	44.45*60.325*8	14	47
3029	TC	44.45*63.5*5.52	14	52
3030	TC	44.5*62*10	13	51
3031	TC	44.5*63.5*9	14	52
3032	TC	44.50*63.50*9.50	14	52
3033	TC	44.5*63.5*9.5	13	52
3034	TC	45*50*8	11	32
3035	TC	45*50*10	11	32
3036	TC	45*52*4	9.5	33.5
3037	TC	45*52*7	9.5	33.5
3038	TC	45*52*8	9.5	33.5
3039	TC	45*54*4.5	11	35
3040	TC	45*55*5	10	40
3041	TC	45*55*6	10	40
3042	TC	45*55*7	10	40
3043	TC	45*55*8	10	40
3044	TC	45*55*10	10	43
3045	TC	45*55*12	10	44
3046	TC	45*56*7	10	43
3047	TC	45*56*8	10.5	43
3048	TC	45*56*10	10.5	43
3049	TC	45*57*7	11	45
3050	TC	45*57*8	11	45
3051	TC	45*57*9	11	45
3052	TC	45*57*11	12	47
3053	TC	45*58*4	11.5	45
3054	TC	45*58*7	11	45
3055	TC	45*58*8	11	45
3056	TC	45*58*9	11.5	45
3057	TC	45*58*10	11	46
3058	TC	45*58*12	11.5	47
3059	TC	45*59*7	11.5	43
3060	TC	45*59*10	11.5	46
3061	TC	45*60*6	11.5	46
3062	TC	45*60*7	11.5	46
3063	TC	45*60*8	11.5	46
3064	TC	45*60*9	11.5	46
3065	TC	45*60*10	11.5	46
3066	TC	45*60*12	12	48
3067	TC	45*60*16	14	65
3068	TC	45*61*9	14	51
3069	TC	45*61*10	14	51
3070	TC	45*62*4	13	51
3071	TC	45*62*7	11.5	48
3072	TC	45*62*8	11.5	48
3073	TC	45*62*9	12	48
3074	TC	45*62*10	11.5	48
3075	TC	45*62*12	11.5	52
3076	TC	45*63*7	13	45
3077	TC	45*63.5*9.5	13	52
3078	TC	45*63.5*10	13	62
3079	TC	45*63.5*12	13	72

序号	类型	规格	丁腈橡胶单价RMB	氟橡胶单价RMB
NO.	TYPE	SPECIFICATION	NBR PRICE	FKM PRICE
3080	TC	45*64*7	13	48
3081	TC	45*64*8	13	50
3082	TC	45*64*9	13	50
3083	TC	45*64*10	13	50
3084	TC	45*64*12	13	52
3085	TC	45*64*14.5	13	72
3086	TC	45*65*5	12	50
3087	TC	45*65*6	12	50
3088	TC	45*65*7	13	51
3089	TC	45*65*8	12	51
3090	TC	45*65*9	13	51
3091	TC	45*65*10	12	51
3092	TC	45*65*11	15	53
3093	TC	45*65*12	13	57
3094	TC	45*65*14	13	65
3095	TC	45*65*25	25	80
3096	TC	45*65.5*7	14	53
3097	TC	45*66*7	13.5	51
3098	TC	45*66*10	13	53
3099	TC	45*67*8	13	53
3100	TC	45*67*10	13.5	55
3101	TC	45*68*8	13	53
3102	TC	45*68*8.5	13	53
3103	TC	45*68*9	13	53
3104	TC	45*68*10	13	53
3105	TC	45*68*12	13.7	56
3106	TC	45*68*9/16.5	15	70
3107	TC	45*69*10	14	60
3108	TC	45*70*5	13.5	50
3109	TC	45*70*8	13.5	58
3110	TC	45*70*8.5	13.5	58
3111	TC	45*70*10	13.5	58
3112	TC	45*70*12	13	62
3113	TC	45*72*5	14	55
3114	TC	45*72*7	14	59
3115	TC	45*72*8	13.5	59
3116	TC	45*72*8.5	14	59
3117	TC	45*72*9.5	14.5	59
3118	TC	45*72*10	13.8	59
3119	TC	45*72*12	15.1	63
3120	TC	45*72*15	17	73
3121	TC	45*73*10	15.5	63
3122	TC	45*73*12	15.5	65
3123	TC	45*74*11	16.5	64
3124	TC	45*75*7	14.5	63
3125	TC	45*75*8	14	63
3126	TC	45*75*10	14.8	63
3127	TC	45*75*12	16.5	67
3128	TC	45*76*10	15.5	63
3129	TC	45*76*12	16.5	63
3130	TC	45*78*8	15	64
3131	TC	45*78*10	16.5	64
3132	TC	45*78*12	17	65
3133	TC	45*80*7	15.5	66
3134	TC	45*80*8	15.5	66
3135	TC	45*80*10	16	66
3136	TC	45*80*12	16.6	69
3137	TC	45*80*13	18	96.5
3138	TC	45*81*10	19	75
3139	TC	45*82*12	19	74
3140	TC	45*84.5*10	18	71
3141	TC	45*85*8	16.5	68
3142	TC	45*85*10	17	68
3143	TC	45*85*12	18.5	68
3144	TC	45*85*13	19	75
3145	TC	45*88.5*12.5	18	75
3146	TC	45*90*8	20	95.2
3147	TC	45*90*10	20	70
3148	TC	45*90*12	20	75
3149	TC	45*93*5.8	19	72
3150	TC	45*93*8.5	19	72
3151	TC	45*94*10	24	83

现货油封 OIL SEAL IN STOCK

序号	类型	规格	丁腈橡胶单价RMB	氟橡胶单价RMB
NO.	TYPE	SPECIFICATION	NBR PRICE	FKM PRICE
3152	TC	45*95*10	23.5	74
3153	TC	45*100*10	28	90
3154	TC	45*100*12	28	90
3155	TC	45.5*85*10	19	75
3156	TC	46*58*5	11.5	42
3157	TC	46*58*6	11.5	45
3158	TC	46*58*7	11.5	45
3159	TC	46*58*10	11.5	45
3160	TC	46*59*10	11.5	46
3161	TC	46*60*7	12	46
3162	TC	46*60*10	13	48
3163	TC	46*62*7	11.5	48
3164	TC	46*62*8	13	48
3165	TC	46*62*8/14	13	71.7
3166	TC	46*63*7	12	45
3167	TC	46*64*8	13	50
3168	TC	46*64*10	13	50
3169	TC	46*65*7	13	51
3170	TC	46*65*9	13	51
3171	TC	46*65*10	13	51
3172	TC	46*68*8	13.5	53
3173	TC	46*70*8	14	58
3174	TC	46*72*10	15	59
3175	TC	46*78*10	16.4	64
3176	TC	46*85*9.5	16	68
3177	TC	47*56*7	10.5	43
3178	TC	47*57*7	11	45
3179	TC	47*57*11	11	47
3180	TC	47*58*7	11.5	45
3181	TC	47*58*10	11.5	45
3182	TC	47*60*7	12	46
3183	TC	47*60*8	12	46
3184	TC	47*60*10	13	46
3185	TC	47*61*8	13	51
3186	TC	47*62*6	12	48
3187	TC	47*62*7	11.5	48
3188	TC	47*62*8	13	48
3189	TC	47*65*8	13	51
3190	TC	47*65*10	13	51
3191	TC	47*68*8	13.5	53
3192	TC	47*68*10	13.5	53
3193	TC	47*70*8	14	58
3194	TC	47*70*9	14	58
3195	TC	47*70*10	14	58
3196	TC	47*70*12	14	60
3197	TC	47*71*10	14	58
3198	TC	47*72*8	14	59
3199	TC	47*72*10	15	62
3200	TC	47*72*12	15.5	64
3201	TC	47*74*16.7	20	71
3202	TC	47*76*12	16.5	66
3203	TC	47*79.5*12.7	18	70
3204	TC	47*80*10	16.7	66
3205	TC	47*80*12	18	73
3206	TC	47*84*10	18	71
3207	TC	47*84*12	19	71
3208	TC	47*84*12.5	19	71
3209	TC	47*88*10	19	73
3210	TC	47*90*12	20	75
3211	TC	47.22*80.29*19.05	25	85
3212	TC	47.5*70.5*9	120	58
3213	TC	47.5*70.6*9	14	58
3214	TC	47.5*70.65*9	14	58
3215	TC	47.5*70.7*9	14	58
3216	TC	47.6*63.5*9.5	13	52
3217	TC	47.6*70*13	14	65
3218	TC	47.6*70.6*11	15	58
3219	TC	47.6*76.5*9.5	16.5	63
3220	TC	47.6*79.5*12.7	18.5	70
3221	TC	47.62*65.05*7.95	14	53
3222	TC	47.62*65.07*6.35	14	53
3223	TC	47.63*63.50*9.53	13	52

序号	类型	规格	丁腈橡胶单价RMB	氟橡胶单价RMB
NO.	TYPE	SPECIFICATION	NBR PRICE	FKM PRICE
3224	TC	47.63*70.8*16	15	58
3225	TC	48*55*7	10	40
3226	TC	48*56*7	12	43
3227	TC	48*57*7	11	45
3228	TC	48*58*4	11	40
3229	TC	48*58*7	11	45
3230	TC	48*58*9.2	11	45
3231	TC	48*58*10	11	45
3232	TC	48*59*12	11.5	46
3233	TC	48*60*7	13	46
3234	TC	48*60*8	12	46
3235	TC	48*60*9	12	46
3236	TC	48*60*10	12	46
3237	TC	48*62*6	13	48
3238	TC	48*62*7	12	48
3239	TC	48*62*8	11.5	48
3240	TC	48*62*9	12	48
3241	TC	48*62*10	11.7	48
3242	TC	48*62*12	11.5	50
3243	TC	48*62*13	13	52
3244	TC	48*62*8/13	13	72.5
3245	TC	48*62*9/24	15	75.5
3246	TC	48*62*7/8.8	13	70.5
3247	TC	48*63*10	13	49
3248	TC	48*63.5*10	13	62
3249	TC	48*63.5*12	13	72
3250	TC	48*64*10	13	50
3251	TC	48*64*12	13	52
3252	TC	48*65*7	13	51
3253	TC	48*65*8	13	51
3254	TC	48*65*9	12	51
3255	TC	48*65*10	13	51
3256	TC	48*65*12	13	52
3257	TC	48*66*7	13	51
3258	TC	48*67*9	13.5	53
3259	TC	48*67*10	13.5	55
3260	TC	48*68*7	13	53
3261	TC	48*68*8	11.7	53
3262	TC	48*68*9	13.5	53
3263	TC	48*68*10	13	53
3264	TC	48*68*12	13	56
3265	TC	48*68*13	13.5	68
3266	TC	48*68.5*9.5	13.5	55
3267	TC	48*69*10	14	60
3268	TC	48*70*7	14	58
3269	TC	48*70*8	14	58
3270	TC	48*70*9	13.5	58
3271	TC	48*70*10	13.5	58
3272	TC	48*70*12	13.5	58
3273	TC	48*70.5*9	14	58
3274	TC	48*72*7	14	59
3275	TC	48*72*8	14	59
3276	TC	48*72*9	14	59
3277	TC	48*72*10	15	59
3278	TC	48*72*11	15.5	63
3279	TC	48*72*12	15.5	63
3280	TC	48*72.10*7	14	59
3281	TC	48*72.5*10	14	59
3282	TC	48*73*7	14	60
3283	TC	48*73*10	15.5	63
3284	TC	48*73*12	16	63
3285	TC	48*74*10	15	63
3286	TC	48*74*12	16	63
3287	TC	48*75*8	14.5	63
3288	TC	48*75*9	15	63
3289	TC	48*75*10	15.5	63
3290	TC	48*75*12	16.5	67
3291	TC	48*76*10	15.5	63
3292	TC	48*76*12	17	66
3293	TC	48*76.3*13	16.5	67
3294	TC	48*80*8	15	66
3295	TC	48*80*10	16.5	69

现货油封 OIL SEAL IN STOCK

序号	类型	规格	丁腈橡胶单价RMB	氟橡胶单价RMB
NO.	TYPE	SPECIFICATION	NBR PRICE	FKM PRICE
3296	TC	48*80*12	18	70
3297	TC	48*80*13	19	76
3298	TC	48*80*14	20	80
3299	TC	48*80.5*13	16	75
3300	TC	48*82*10	18	67
3301	TC	48*82*12	18	67
3302	TC	48*85*10	19	72
3303	TC	48*90*10	20	70
3304	TC	48*90*13	22.5	88
3305	TC	48*100*10	28	90
3306	TC	48*102*10	35	88
3307	TC	49*56*9	12	43
3308	TC	49*59*10	11.5	46
3309	TC	49*60*10	12	46
3310	TC	49*63*9	13	49
3311	TC	49*65*7	13	51
3312	TC	49*65*9	14	52
3313	TC	49*66.8*9	13.5	53
3314	TC	49*67*11	13.5	60
3315	TC	49*68*8	12.5	53
3316	TC	49*70*18	25	58
3317	TC	49*72*8	13.5	59
3318	TC	49*72*10	15	59
3319	TC	49*102*10	30	88
3320	TC	49.2*63.5*9.5	13	52
3321	TC	49.2*66.6*9.5	13	53
3322	TC	49.2*68.2*9.5	13.5	55
3323	TC	49.21*68.22*7	13.5	55
3324	TC	49.5*77*18	20	80
3325	TC	50*56*7	12	43
3326	TC	50*58*4	11.5	40
3327	TC	50*60*4	12	35
3328	TC	50*60*6	12	40
3329	TC	50*60*7	12	46
3330	TC	50*60*8	12	46
3331	TC	50*60*10	12	46
3332	TC	50*60*12	13	46
3333	TC	50*62*5	12	45
3334	TC	50*62*7	11.5	48
3335	TC	50*62*8	12	48
3336	TC	50*62*9	13	48
3337	TC	50*62*10	11.5	48
3338	TC	50*62*11	13	52
3339	TC	50*62*12	12	53
3340	TC	50*63*6	12	45
3341	TC	50*63*7	13	45
3342	TC	50*63*8	13	49
3343	TC	50*63*10	13	49
3344	TC	50*64*6.5	13	50
3345	TC	50*64*8	13	50
3346	TC	50*64*10	13	50
3347	TC	50*65*7	13	51
3348	TC	50*65*8	12	51
3349	TC	50*65*9	13	51
3350	TC	50*65*10	13	51
3351	TC	50*65*12	13	52
3352	TC	50*65*13	14	56
3353	TC	50*65*10/14	15	74.5
3354	TC	50*65.3*8	13	60.8
3355	TC	50*65.5*13/15.5	15	63.7
3356	TC	50*66*6	13.5	51
3357	TC	50*66*8	13	51
3358	TC	50*66*10	13.5	51
3359	TC	50*66*13	14	65
3360	TC	50*67*7	13	53
3361	TC	50*67*8	13	53
3362	TC	50*67*9	13	53
3363	TC	50*67*10	13	57
3364	TC	50*67*11	13	57
3365	TC	50*68*5	12.5	53
3366	TC	50*68*6	12.5	53
3367	TC	50*68*7	13.5	53

序号	类型	规格	丁腈橡胶单价RMB	氟橡胶单价RMB
NO.	TYPE	SPECIFICATION	NBR PRICE	FKM PRICE
3368	TC	50*68*8	12.5	53
3369	TC	50*68*9	13	53
3370	TC	50*68*10	13	53
3371	TC	50*68*11	13.5	57
3372	TC	50*68*12	13.5	57
3373	TC	50*70*7	14	55
3374	TC	50*70*8	13	58
3375	TC	50*70*9	13.5	58
3376	TC	50*70*9.5	13.5	58
3377	TC	50*70*10	13	58
3378	TC	50*70*11	14	62
3379	TC	50*70*12	13	62
3380	TC	50*71.90*12	15	58
3381	TC	50*72*5	14	55
3382	TC	50*72*6	13	55
3383	TC	50*72*7	14	59
3384	TC	50*72*8	13.5	59
3385	TC	50*72*9	14	59
3386	TC	50*72*10	13.7	59
3387	TC	50*72*12	14.4	59
3388	TC	50*72*14	16.2	72
3389	TC	50*72*11/17	14	70
3390	TC	50*72.1*10	14.5	59
3391	TC	50*73*9	14	63
3392	TC	50*73*10	15	63
3393	TC	50*73*12	16	63
3394	TC	50*74*10	15	63
3395	TC	50*74*12	15	63
3396	TC	50*75*7	14	63
3397	TC	50*75*8	14.5	63
3398	TC	50*75*10	14.5	63
3399	TC	50*75*12	15	67
3400	TC	50*76*7	14.5	63
3401	TC	50*76*10	15.5	63
3402	TC	50*76*12	17.5	63
3403	TC	50*76*12/18	18	92.7
3404	TC	50*76.5*13	16.5	67
3405	TC	50*78*8	15	64
3406	TC	50*78*10	16	64
3407	TC	50*78*12	17	67
3408	TC	50*80*6	15	66
3409	TC	50*80*8	15	66
3410	TC	50*80*9	16	66
3411	TC	50*80*10	15.5	66
3412	TC	50*80*12	16.5	69
3413	TC	50*80*13	18	74
3414	TC	50*81*10	17	75
3415	TC	50*82*8	16	67
3416	TC	50*82*10	17	67
3417	TC	50*82*12	18	70
3418	TC	50*85*8	16.6	68
3419	TC	50*85*10	18.5	68
3420	TC	50*85*12	19.5	68
3421	TC	50*85*13	20	78
3422	TC	50*87*12.7	19.6	74
3423	TC	50*90*8	19	70
3424	TC	50*90*10	19	71
3425	TC	50*90*12	20	75
3426	TC	50*90*13	20.5	79
3427	TC	50*91*9	20	71
3428	TC	50*92*8	20.6	71
3429	TC	50*92*10	20	71
3430	TC	50*95*10	23	74
3431	TC	50*95*12	25	93
3432	TC	50*100*8.5	30	84
3433	TC	50*100*10	28	90
3434	TC	50*100*12	28	100
3435	TC	50*100*13	30	100
3436	TC	50*110*10	35	100
3437	TC	50*110*12	35	113
3438	TC	50.80*63.50*6.35	13	52
3439	TC	50.8*66.7*9.5	13	53

现货油封 OIL SEAL IN STOCK

序号	类型	规格	丁腈橡胶单价RMB	氟橡胶单价RMB
NO.	TYPE	SPECIFICATION	NBR PRICE	FKM PRICE
3440	TC	50.8*69.8*9.5	14	60
3441	TC	50.8*69.85*9.53	14	60
3442	TC	50.8*76.2*12.7	16.5	96.8
3443	TC	50.8*76.2*12.7	16.5	96.8
3444	TC	51*57*3	10	45
3445	TC	51*60.1*6.2	13	47
3446	TC	51*63*6	13	46
3447	TC	51*63*7	12	46
3448	TC	51*63*9	12	46
3449	TC	51*65*6	13.5	51
3450	TC	51*65*8.5	14	51
3451	TC	51*66*7	13.5	51
3452	TC	51*70*9.5	14	58
3453	TC	51*70*10	14	58
3454	TC	51*70*11	14	63
3455	TC	51*70*12	14	64
3456	TC	51*76*9.5	16	63
3457	TC	51*76*10	16	63
3458	TC	51*76*13	16.5	66
3459	TC	51*80*7	16	66
3460	TC	51*101*5	28	84
3461	TC	51.9*68*8/10	13	57
3462	TC	52*60*7	13	46
3463	TC	52*60*8	14	46
3464	TC	52*62*7	11.5	48
3465	TC	52*62*8	11.18	48
3466	TC	52*62*9	11.18	48
3467	TC	52*62*10	13	51
3468	TC	52*63*6	11.5	46
3469	TC	52*63*8	12	46
3470	TC	52*63*9	12	46
3471	TC	52*64*9	13	50
3472	TC	52*65*7	13	51
3473	TC	52*65*8	13	51
3474	TC	52*65*9	13	51
3475	TC	52*65*10	13	51
3476	TC	52*65*13	14	51
3477	TC	52*66*7	13	51
3478	TC	52*66*8	13	51
3479	TC	52*66*9	13	51
3480	TC	52*66*10	13	51
3481	TC	52*67*6.7	13	53
3482	TC	52*67*7	13	53
3483	TC	52*68*7	13	53
3484	TC	52*68*8	13	53
3485	TC	52*68*9	13.5	53
3486	TC	52*68*10	13	53
3487	TC	52*68*13	14	57
3488	TC	52*68*7/13	14	78.7
3489	TC	52*68.5*8	15	55
3490	TC	52*69*10	14	60
3491	TC	52*70*7	13.5	58
3492	TC	52*70*8	13.5	58
3493	TC	52*70*9	13.5	58
3494	TC	52*70*10	13.5	58
3495	TC	52*70*12	13.5	60
3496	TC	52*70*13	14	64
3497	TC	52*71*8	13.5	58
3498	TC	52*71*9	15	58
3499	TC	52*72*7	14	59
3500	TC	52*72*8	13.5	59
3501	TC	52*72*9	14	59
3502	TC	52*72*10	13.5	59
3503	TC	52*72*12	14.4	61
3504	TC	52*72*12.5	15	63
3505	TC	52*73*10	14.8	63
3506	TC	52*74*9	15	63
3507	TC	52*74*12	16.5	69
3508	TC	52*75*8	14	63
3509	TC	52*75*10	15	63
3510	TC	52*75*12	16	65
3511	TC	52*76*9	15	63

序号	类型	规格	丁腈橡胶单价RMB	氟橡胶单价RMB
NO.	TYPE	SPECIFICATION	NBR PRICE	FKM PRICE
3512	TC	52*76*10	15.5	63
3513	TC	52*78*8	14.5	64
3514	TC	52*78*10	16	64
3515	TC	52*80*8	15.5	66
3516	TC	52*80*10	16.5	66
3517	TC	52*80*12	17.5	71
3518	TC	52*80*13	18	75
3519	TC	52*82*10	18	70
3520	TC	52*84*12	19	71
3521	TC	52*84*14	19.5	75
3522	TC	52*85*9	18	68
3523	TC	52*85*10	18.5	72
3524	TC	52*85*12	18.5	68
3525	TC	52*85*13	19.8	78
3526	TC	52*90*10	19	70
3527	TC	52*92*13	24	84
3528	TC	52*100*10	28	84
3529	TC	52*100*15	28	105
3530	TC	52*122*10.5	50	125
3531	TC	53*63*8	12	46
3532	TC	53*68*7	13.5	53
3533	TC	53*68*9	13.5	53
3534	TC	53*68*10	13.5	53
3535	TC	53*70*9	14	58
3536	TC	53*71*9	14	58
3537	TC	53*72*10	14	59
3538	TC	53*73*7	14	55
3539	TC	53*73*10	14.9	63
3540	TC	53*75*12	16	65
3541	TC	53*80*8	15	66
3542	TC	53*80*10	16	66
3543	TC	53*80*12	17	69
3544	TC	53*80*13	17.5	75
3545	TC	54*64*8	13	50
3546	TC	54*64*9	13	50
3547	TC	54*65*8	13.5	51
3548	TC	54*65*10	13.5	51
3549	TC	54*65*12	14	51
3550	TC	54*65*13	13.5	51
3551	TC	54*66*7	13	51
3552	TC	54*66*8	13	51
3553	TC	54*66*10	13	51
3554	TC	54*68*7	13	53
3555	TC	54*68*8	13	53
3556	TC	54*68*9	13.5	53
3557	TC	54*68*10	13.5	53
3558	TC	54*68*10.5	13.5	53
3559	TC	54*69*7.5/9.5	14	76.7
3560	TC	54*70*6.7	14	58
3561	TC	54*70*7	14	58
3562	TC	54*70*8	14	58
3563	TC	54*70*9	14	58
3564	TC	54*70*10	14	58
3565	TC	54*70*12	13.5	58
3566	TC	54*71*8	13	58
3567	TC	54*72*7	14	59
3568	TC	54*72*8	14	59
3569	TC	54*72*10	14.2	59
3570	TC	54*73*8	14	63
3571	TC	54*73*10	14.5	63
3572	TC	54*74*10	14.5	63
3573	TC	54*75*8	15	63
3574	TC	54*75*10	15	63
3575	TC	54*75*12	16	63
3576	TC	54*75*12.5	16	70
3577	TC	54*76*8	15	63
3578	TC	54*76*9	15	63
3579	TC	54*76*12	16.5	64
3580	TC	54*77*10	15	67
3581	TC	54*80*10	16	66
3582	TC	54*80*12	17	69
3583	TC	54*80*13	18	80

现货油封 OIL SEAL IN STOCK

序号	类型	规格	丁腈橡胶单价RMB	氟橡胶单价RMB
NO.	TYPE	SPECIFICATION	NBR PRICE	FKM PRICE
3584	TC	54*81*10	17	75
3585	TC	54*81*12	19	75
3586	TC	54*82*10	17	67
3587	TC	54*82*11	17	67
3588	TC	54*85*8	16.5	68
3589	TC	54*85*10	17.4	68
3590	TC	54*85*12	16.5	70
3591	TC	54*85*13	19	78
3592	TC	54*90*10	20	70
3593	TC	54.8*70*9	14	58
3594	TC	55*65*7	13	51
3595	TC	55*65*8	13	51
3596	TC	55*65*10	13	51
3597	TC	55*65*12	14	51
3598	TC	55*68*6	13.5	53
3599	TC	55*68*7	13	53
3600	TC	55*68*8	13	53
3601	TC	55*68*8.5	13.5	53
3602	TC	55*68*9	13.5	53
3603	TC	55*68*10	13	53
3604	TC	55*68*12	13.5	53
3605	TC	55*70*7	14	58
3606	TC	55*70*8	13.5	58
3607	TC	55*70*9	14	58
3608	TC	55*70*10	13.5	58
3609	TC	55*70*12	13.5	58
3610	TC	55*70*13	14	62
3611	TC	55*70*8/10	14	60
3612	TC	55*72*4	13	59
3613	TC	55*72*6	13	59
3614	TC	55*72*7	14	59
3615	TC	55*72*8	13.5	59
3616	TC	55*72*9	14	59
3617	TC	55*72*10	13.5	59
3618	TC	55*72*12	15	59
3619	TC	55*73*7	14	63
3620	TC	55*73*10	14.4	63
3621	TC	55*73*13	16	65
3622	TC	55*74*7	14.5	63
3623	TC	55*75*6	14.5	58
3624	TC	55*75*7	15	60
3625	TC	55*75*8	14	63
3626	TC	55*75*9	15	63
3627	TC	55*75*10	14.5	63
3628	TC	55*75*12	15	65
3629	TC	55*76*10	15	63
3630	TC	55*76*12	15.5	63
3631	TC	55*77*10	15	67
3632	TC	55*77*14	20	75
3633	TC	55*78*7	16	64
3634	TC	55*78*8	15	64
3635	TC	55*78*9	15	64
3636	TC	55*78*10	16	64
3637	TC	55*78*12	16	64
3638	TC	55*80*8	15	66
3639	TC	55*80*10	15	66
3640	TC	55*80*11	16	69
3641	TC	55*80*12	17	69
3642	TC	55*80*13	17.5	75
3643	TC	55*81*10	17	75
3644	TC	55*82*8	16	67
3645	TC	55*82*9	16	67
3646	TC	55*82*10	16.8	67
3647	TC	55*82*12	18.5	70
3648	TC	55*82*13	19	72
3649	TC	55*85*7	16.5	68
3650	TC	55*85*8	16.8	68
3651	TC	55*85*10	17	68
3652	TC	55*85*12	17.5	68
3653	TC	55*85*13	20	77
3654	TC	55*85*14	22	78
3655	TC	55*88*8	19	73

序号	类型	规格	丁腈橡胶单价RMB	氟橡胶单价RMB
NO.	TYPE	SPECIFICATION	NBR PRICE	FKM PRICE
3656	TC	55*88*10	18.5	73
3657	TC	55*90*8	18	70
3658	TC	55*90*9	18	73
3659	TC	55*90*10	18	73
3660	TC	55*90*12	19.6	73
3661	TC	55*90*13	20.5	84
3662	TC	55*92*9	20	71
3663	TC	55*95*10	23	74
3664	TC	55*95*12	25	93
3665	TC	55*100*8	26	84
3666	TC	55*100*10	24	84
3667	TC	55*100*12	26.5	91
3668	TC	55*100*13	28	91
3669	TC	55*101*4.7	30	88
3670	TC	55*110*8	35	100
3671	TC	55*110*10	35	100
3672	TC	55*110*12	35	100
3673	TC	55*110*12/9.5	35	155
3674	TC	55*135*10	47	135
3675	TC	56*66*11	13.5	53
3676	TC	56*66*17	15	53
3677	TC	56*68*8	13.5	53
3678	TC	56*70*8	14	58
3679	TC	56*70*9	14	58
3680	TC	56*72*7	14	59
3681	TC	56*72*8	14	59
3682	TC	56*72*9	14	59
3683	TC	56*72*10	14	59
3684	TC	56*73*7	14	63
3685	TC	56*73*10	14.5	63
3686	TC	56*73.15*10	14.5	65
3687	TC	56*75*8	15	63
3688	TC	56*76*6	15	55
3689	TC	56*76*9	15	63
3690	TC	56*80*8	16	66
3691	TC	56*80*10	16	69
3692	TC	56*80*13	18	75
3693	TC	56*85*8	16.5	68
3694	TC	56*85*10	17.3	68
3695	TC	56*86*12.9	19	78
3696	TC	56*88*8	17	73
3697	TC	56*90*8	19	70
3698	TC	56*90*10	18.5	70
3699	TC	56*92*12	22.5	82
3700	TC	56*100*10	28	84
3701	TC	56*112*10	50	115
3702	TC	56*122.5*8/10	50	150
3703	TC	57*67*6	13	53
3704	TC	57*71*7	14	58
3705	TC	57*71*8	14	58
3706	TC	57*72*12	14	59
3707	TC	57*73*7	14	55
3708	TC	57*73*12	14.5	63
3709	TC	57*75*10	14.5	63
3710	TC	57*75*12	16.5	65
3711	TC	57*76*8	15	63
3712	TC	57*76*10	15	63
3713	TC	57*76*8/10.5	15	64
3714	TC	57*76.3*12.5	16.5	67
3715	TC	57*78*10	15.3	64
3716	TC	57*79*10.5	15	66
3717	TC	57*79*13.5	16	70
3718	TC	57*80*10	16	66
3719	TC	57*80*12	16.5	69
3720	TC	57*85*10	17.2	68
3721	TC	57*85*12	19	68
3722	TC	57*89*12.5	19	80
3723	TC	57*90*10	18.5	71
3724	TC	57*92.2*12.7	20	78
3725	TC	57*112*10	50	115
3726	TC	57*121*17	60	140
3727	TC	57*124*10	50	120

现货油封 OIL SEAL IN STOCK

序号	类型	规格	丁腈橡胶单价RMB	氟橡胶单价RMB
NO.	TYPE	SPECIFICATION	NBR PRICE	FKM PRICE
3728	TC	57.1*77.8*9.5	15	67
3729	TC	57.1*85.7*12.7	16.5	75
3730	TC	57.15*68.85*9.53	14	55
3731	TC	57.15*69.85*9.53	14	60
3732	TC	57.15*76.2*9.525	15	63
3733	TC	57.15*76.2*9.6	15	63
3734	TC	57.15*76.2*12.7	16.5	67
3735	TC	57.15*76.27*12.7	16.5	67
3736	TC	57.15*88.9*12.7	20	75
3737	TC	57.2*76.2*12.7	17	67
3738	TC	57.5*85.73*12.7	17	78
3739	TC	57.5*85.75*12.7	18	68
3740	TC	58*68*9	13.5	53
3741	TC	58*68*10	13.5	53
3742	TC	58*70*7	14	58
3743	TC	58*70*8	14	58
3744	TC	58*70*9	15	58
3745	TC	58*70*10	13.5	58
3746	TC	58*70*11	15	58
3747	TC	58*70*12	14	58
3748	TC	58*72*8	14	59
3749	TC	58*72*9	14	59
3750	TC	58*72*10	14	59
3751	TC	58*72*12	14	59
3752	TC	58*74*10	14.5	63
3753	TC	58*75*5	14	58
3754	TC	58*75*7	15	60
3755	TC	58*75*8	15	60
3756	TC	58*75*9	14.5	63
3757	TC	58*75*10	14.5	63
3758	TC	58*75*11	15	64
3759	TC	58*75*12	15.5	63
3760	TC	58*75*7.5/11	16	63
3761	TC	58*76*10	15	64
3762	TC	58*76*11	15	64
3763	TC	58*76*12	16	64
3764	TC	58*78*8	15	64
3765	TC	58*78*9	15.1	64
3766	TC	58*78*10	15.1	64
3767	TC	58*78*12	15.9	67
3768	TC	58*78*13	17.4	68
3769	TC	58*79*9	15	66
3770	TC	58*80*8	16	66
3771	TC	58*80*9	16	66
3772	TC	58*80*10	15.5	66
3773	TC	58*80*12	17.5	73
3774	TC	58*80*13	18	75
3775	TC	58*81.2*10	17	75
3776	TC	58*82*10	17	67
3777	TC	58*82*12	18	69
3778	TC	58*82.5*11	17	75
3779	TC	58*84*16	21.5	85
3780	TC	58*85*8	16.5	68
3781	TC	58*85*9	17	68
3782	TC	58*85*10	17.5	68
3783	TC	58*85*12	18.5	74
3784	TC	58*86*12	16	78
3785	TC	58*86*13	16	79
3786	TC	58*88*8	18	73
3787	TC	58*89*10	18.5	73
3788	TC	58*90*10	19	70
3789	TC	58*90*12	20.5	84
3790	TC	58*90*13	20.5	84
3791	TC	58*92*8	19.5	71
3792	TC	58*100*13	27	91
3793	TC	58*103*12	27	100
3794	TC	59*72*12	14	59
3795	TC	59*72*12/13	14	59
3796	TC	59*75*10	14.5	63
3797	TC	59*80*8	16	66
3798	TC	59*85*12	19	74
3799	TC	59*86*13	16	79

序号	类型	规格	丁腈橡胶单价RMB	氟橡胶单价RMB
NO.	TYPE	SPECIFICATION	NBR PRICE	FKM PRICE
3800	TC	59*90*10	20.5	84
3801	TC	60*70*7	14	58
3802	TC	60*70*8	13.5	58
3803	TC	60*70*10	14	58
3804	TC	60*70*12	15	58
3805	TC	60*72*7.5	15	59
3806	TC	60*72*8	13.5	59
3807	TC	60*72*9	14	59
3808	TC	60*72*10	13.5	59
3809	TC	60*72*12	13.5	59
3810	TC	60*74*8	14.5	63
3811	TC	60*74*10	14.5	63
3812	TC	60*75*6	14.5	63
3813	TC	60*75*7	15	63
3814	TC	60*75*8	14	63
3815	TC	60*75*9	15	63
3816	TC	60*75*10	14.5	63
3817	TC	60*75*12	15	63
3818	TC	60*76*8	15	63
3819	TC	60*76*9	15	63
3820	TC	60*76*10	15	63
3821	TC	60*77*10	15	67
3822	TC	60*77*12	16	67
3823	TC	60*78*7	15	64
3824	TC	60*78*8	15	64
3825	TC	60*78*9	15	64
3826	TC	60*78*10	15.5	64
3827	TC	60*78*12	15	64
3828	TC	60*78*13	16.5	66
3829	TC	60*80*7	15	66
3830	TC	60*80*8	15	66
3831	TC	60*80*9	16	66
3832	TC	60*80*10	15	66
3833	TC	60*80*12	15.5	69
3834	TC	60*80*13	18	85
3835	TC	60*80*7/5.5	15	70
3836	TC	60*81*11	17	75
3837	TC	60*82*7	16	67
3838	TC	60*82*8	16	67
3839	TC	60*82*9	16	67
3840	TC	60*82*10	16.8	67
3841	TC	60*82*12	17.5	67
3842	TC	60*82.8*12.5	17.5	75
3843	TC	60*84*10	17.1	71
3844	TC	60*85*7	16.5	68
3845	TC	60*85*8	16	68
3846	TC	60*85*9	16.5	68
3847	TC	60*85*10	16.3	68
3848	TC	60*85*12	17	70
3849	TC	60*85*13	19	78
3850	TC	60*85.1*13	19.5	78
3851	TC	60*85.7*13	17	78
3852	TC	60*86*10	18	73
3853	TC	60*86.5*10	17.4	73
3854	TC	60*88*8	18	73
3855	TC	60*88*12	18.5	74
3856	TC	60*89*10	18	73
3857	TC	60*90*8	18	70
3858	TC	60*90*10	18	70
3859	TC	60*90*11	19	75
3860	TC	60*90*12	18	75
3861	TC	60*90*13	20.5	79
3862	TC	60*91.5*10	20	71
3863	TC	60*92*10	21	71
3864	TC	60*92*12	22	79
3865	TC	60*94*10	20.5	85
3866	TC	60*95*8	21.5	74
3867	TC	60*95*10	20.6	74
3868	TC	60*95*11	23	78
3869	TC	60*95*12	23.5	78
3870	TC	60*95*13	24.5	93
3871	TC	60*96*12	25	85

现货油封 OIL SEAL IN STOCK

序号	类型	规格	丁腈橡胶单价RMB	氟橡胶单价RMB
NO.	TYPE	SPECIFICATION	NBR PRICE	FKM PRICE
3872	TC	60*96.5*10	22.5	75
3873	TC	60*100*10	24	84
3874	TC	60*100*12	26	97
3875	TC	60*100*13	26	100
3876	TC	60*110*10	28	100
3877	TC	60*110*12	30	100
3878	TC	60*110*13	33	110
3879	TC	60*140*15	60	160
3880	TC	60.3*82.5*9.5	16	75
3881	TC	60.33*79.38*9.53	16	66
3882	TC	60.4*79.3*11.1	16	70
3883	TC	60.45*79.37*9.5	16	66
3884	TC	61.8*112*7/9	40	115
3885	TC	62*70*12	15	58
3886	TC	62*72*7	14	59
3887	TC	62*74*8	14.5	63
3888	TC	62*75*7	15	63
3889	TC	62*75*8	15	63
3890	TC	62*75*10	15	63
3891	TC	62*75*12	15	63
3892	TC	62*76*11	14.5	65
3893	TC	62*77*9	15	67
3894	TC	62*78*8	15	64
3895	TC	62*78*10	15	64
3896	TC	62*78*12	16	64
3897	TC	62*80*8	16	66
3898	TC	62*80*9	16	66
3899	TC	62*80*10	16	66
3900	TC	62*80*12	16	66
3901	TC	62*80*13	17.5	75
3902	TC	62*82*10	16.8	67
3903	TC	62*82*12	17	67
3904	TC	62*83*10	16	71
3905	TC	62*85*8	16	68
3906	TC	62*85*10	16	68
3907	TC	62*85*12	18	74
3908	TC	62*85*13	19	76
3909	TC	62*85*8/8.5	16.5	68
3910	TC	62*86*10	16.5	73
3911	TC	62*88*12	19	74
3912	TC	62*90*10	19	70
3913	TC	62*90*12	19.5	70
3914	TC	62*90*13	20	85
3915	TC	62*93*6	19	72
3916	TC	62*93*9	20.5	72
3917	TC	62*93*12	23.5	85
3918	TC	62*93*13	25	86
3919	TC	62*93*16	27	95
3920	TC	62*95*10	22.5	81
3921	TC	62*95*12	23.5	81
3922	TC	62*95*13	25.2	93
3923	TC	62*100*10	24	84
3924	TC	62*100*12	25	86
3925	TC	62*110*10	30	100
3926	TC	62*110*13	28	110
3927	TC	62*120*12	45	120
3928	TC	62.4*100*10	28	84
3929	TC	63*75*9	14.5	63
3930	TC	63*80*8	15	66
3931	TC	63*80*9	16	66
3932	TC	63*80*10	16	66
3933	TC	63*80*11.5	16	69
3934	TC	63*80*12	17	69
3935	TC	63*82*10	17	67
3936	TC	63*83*9.5	17	71
3937	TC	63*83*10	17	71
3938	TC	63*85*10	17	68
3939	TC	63*85*12	18	68
3940	TC	63*88*10	18	73
3941	TC	63*88*12	19	74
3942	TC	63*90*10	19	70
3943	TC	63*90*12	19.5	70

序号	类型	规格	丁腈橡胶单价RMB	氟橡胶单价RMB
NO.	TYPE	SPECIFICATION	NBR PRICE	FKM PRICE
3944	TC	63*90*13	20	85
3945	TC	63*92*10	21	71
3946	TC	63*93*12	22.5	80
3947	TC	63*100*10	24	84
3948	TC	63*100*13	26	93
3949	TC	63.50*76.20*9.53	16.5	63
3950	TC	63.5*82.55*9.5	17.5	75
3951	TC	63.5*82.6*13	17.5	75
3952	TC	63.5*88.9*12.7	20	80
3953	TC	64*80*8	16	66
3954	TC	64*80*10	16	66
3955	TC	64*80*12	16	69
3956	TC	64*80*13	16.5	75
3957	TC	64*83*10	17	71
3958	TC	64*84*11	16.6	75
3959	TC	64*84*16	21.4	83
3960	TC	64*85*10	16.8	68
3961	TC	64*85*12	18	68
3962	TC	64*85*16	20	84
3963	TC	64*89*12	16.5	80
3964	TC	64*89*13	16.5	80
3965	TC	64*89*13.2	16.5	80
3966	TC	64*90*10	20	85
3967	TC	64*90*13	20	85
3968	TC	64*92*12	22.5	76
3969	TC	64*93.3*9	20.5	72
3970	TC	64*95*10	22	78
3971	TC	64.3*78.6*6	15	64
3972	TC	65*75*8	14.5	63
3973	TC	65*75*10	15	63
3974	TC	65*75*12	14.5	63
3975	TC	65*77*4	15	67
3976	TC	65*77*7.5	15	67
3977	TC	65*77*14	20	75
3978	TC	65*78*10	15	64
3979	TC	65*78*12	15	64
3980	TC	65*79*7	15	66
3981	TC	65*79.6*15	22	90
3982	TC	65*80*7	16	66
3983	TC	65*80*8	15	66
3984	TC	65*80*9	15	66
3985	TC	65*80*10	15	66
3986	TC	65*80*12	16.2	66
3987	TC	65*81*7	16	75
3988	TC	65*82*9	16	67
3989	TC	65*82*10	16	67
3990	TC	65*82*12	16.5	67
3991	TC	65*83*13	18.5	71
3992	TC	65*84*9	15.5	71
3993	TC	65*84*10	16.4	71
3994	TC	65*85*8	16	68
3995	TC	65*85*10	16	68
3996	TC	65*85*12	16.8	70
3997	TC	65*85*13	21.5	74
3998	TC	65*85.10*10	17	68
3999	TC	65*85.10*13	18	78
4000	TC	65*86*10	17	73
4001	TC	65*88*7	16.5	73
4002	TC	65*88*8	16.5	73
4003	TC	65*88*10	18	73
4004	TC	65*88*12	19	73
4005	TC	65*88*13	20	80
4006	TC	65*88*12/19	20	108
4007	TC	65*90*8	19	70
4008	TC	65*90*10	18	70
4009	TC	65*90*12	18	76
4010	TC	65*90*13	20	72
4011	TC	65*90*15	19	90
4012	TC	65*92*10	21	74
4013	TC	65*92*11	22	75
4014	TC	65*92*12	22.5	75
4015	TC	65*92*13	23	86

现货油封 OIL SEAL IN STOCK

序号	类型	规格	丁腈橡胶单价RMB	氟橡胶单价RMB
NO.	TYPE	SPECIFICATION	NBR PRICE	FKM PRICE
4016	TC	65*95*8	20	74
4017	TC	65*95*10	21	77
4018	TC	65*95*12	23.5	80
4019	TC	65*95*13	23.5	87
4020	TC	65*95*14	24.5	90
4021	TC	65*100*6	24	75
4022	TC	65*100*7	24	80
4023	TC	65*100*8	24	84
4024	TC	65*100*10	22	84
4025	TC	65*100*12	25.5	84
4026	TC	65*100*13	26	93
4027	TC	65*105*10	30	88
4028	TC	65*105*12	28	96
4029	TC	65*110*10	28	100
4030	TC	65*110*12	28	100
4031	TC	65*110*13	28	110
4032	TC	65*115*12	40	120
4033	TC	65*115*13	40	130
4034	TC	65*120*10	45	120
4035	TC	65*120*12	41.5	130
4036	TC	65*120*13	42.5	132
4037	TC	65*120*15	45	160
4038	TC	65*125*12	45	130
4039	TC	65*125*13	45	130
4040	TC	65*140*14	60	160
4041	TC	65.3*85.7*9.5	16.5	75
4042	TC	66*80*9	16	66
4043	TC	66*86*9	16.5	70
4044	TC	66*88*12	18.5	73
4045	TC	66*89*9	17.5	73
4046	TC	66.04*95.27*14	25	95
4047	TC	66.5*89*13	20	80
4048	TC	66.6*95.3*12.7	25	92
4049	TC	66.67*89.3*10	19	78
4050	TC	66.675*93.853*14.275	25	95
4051	TC	67*82*7	16	67
4052	TC	67*85*10	16.5	68
4053	TC	67*86*8	17	70
4054	TC	67*88*9	17	73
4055	TC	68*80*8	15	66
4056	TC	68*80*8.5	15	66
4057	TC	68*80*10	15.5	66
4058	TC	68*80*12	16	66
4059	TC	68*82*7	16	67
4060	TC	68*82*8	16	67
4061	TC	68*82*10	16	67
4062	TC	68*83*10	16	71
4063	TC	68*85*8	16.5	68
4064	TC	68*85*10	16.5	68
4065	TC	68*85*12	17.5	68
4066	TC	68*85*13	17.5	69
4067	TC	68*86*8	16.5	70
4068	TC	68*88*8	18	73
4069	TC	68*88*10	17.1	73
4070	TC	68*89*13	18	80
4071	TC	68*90*8	18	70
4072	TC	68*90*10	18	70
4073	TC	68*90*12	19.5	80
4074	TC	68*90*13	20	80
4075	TC	68*92*6	20.5	71
4076	TC	68*92*10	20.5	71
4077	TC	68*92*12	21	71
4078	TC	68*95*8	20	74
4079	TC	68*95*10	21.5	74
4080	TC	68*95*12	23	86
4081	TC	68*95*13	23	81
4082	TC	68*98*10	22	75
4083	TC	68*99*14	25	95
4084	TC	68*100*10	23	84
4085	TC	68*100*12	25	87
4086	TC	68*100*13	25	84
4087	TC	68*110*10	28	100

序号	类型	规格	丁腈橡胶单价RMB	氟橡胶单价RMB
NO.	TYPE	SPECIFICATION	NBR PRICE	FKM PRICE
4088	TC	68*110*12	28	100
4089	TC	68*110*13	28	100
4090	TC	68*120*7	45	110
4091	TC	68*135*10	47	135
4092	TC	69*78*5	15	64
4093	TC	69*85*8	16.5	68
4094	TC	69*85*10	16.5	68
4095	TC	69*89*13	18	80
4096	TC	69*92*12	21.5	73
4097	TC	69*92*14	25	85
4098	TC	69*95*10	21.5	77
4099	TC	70*80*6	16	58
4100	TC	70*80*7	16	66
4101	TC	70*80*8	16	66
4102	TC	70*80*10	16	66
4103	TC	70*80*12	16	66
4104	TC	70*80*7/7.5	16	66
4105	TC	70*82*5	16	67
4106	TC	70*82*10	16	67
4107	TC	70*82*12	16	67
4108	TC	70*85*7	16	68
4109	TC	70*85*8	16	68
4110	TC	70*85*9	16	68
4111	TC	70*85*10	16	68
4112	TC	70*85*12	16.5	68
4113	TC	70*85*15	17	78
4114	TC	70*87*7	16.5	73
4115	TC	70*87*8.5	16.5	73
4116	TC	70*87*10	16.5	73
4117	TC	70*88*8	16.5	73
4118	TC	70*88*9	16.5	73
4119	TC	70*88*10	16.5	73
4120	TC	70*88*12	18	75
4121	TC	70*90*7	19	70
4122	TC	70*90*8	18	70
4123	TC	70*90*10	18	70
4124	TC	70*90*12	18	70
4125	TC	70*90*13	19.5	78
4126	TC	70*90*7/5.5	18	75
4127	TC	70*92*7	18	71
4128	TC	70*92*8	18.5	71
4129	TC	70*92*8.5	20	71
4130	TC	70*92*9	19	71
4131	TC	70*92*10	20.3	71
4132	TC	70*92*12	22	80
4133	TC	70*92*14	23	80
4134	TC	70*92*16	25	90
4135	TC	70*94*10	21	72
4136	TC	70*95*5	20	67
4137	TC	70*95*8	20	74
4138	TC	70*95*10	20	74
4139	TC	70*95*12	21	74
4140	TC	70*95*13	23	82
4141	TC	70*95*17	30	105
4142	TC	70*96*11	23	75
4143	TC	70*96*13	25	92
4144	TC	70*100*8	22	84
4145	TC	70*100*10	22	84
4146	TC	70*100*12	22.5	84
4147	TC	70*100*13	25.5	86
4148	TC	70*100*14	25	84
4149	TC	70*100*15	28	105
4150	TC	70*100*5.2/6.5	25	84
4151	TC	70*102*12	25	93
4152	TC	70*105*10	25	88
4153	TC	70*105*12	26.5	93
4154	TC	70*105*13	27	103
4155	TC	70*105*14	25	110
4156	TC	70*110*8	28	100
4157	TC	70*110*10	26.5	100
4158	TC	70*110*12	27	100
4159	TC	70*110*13	28.5	110

现货油封 OIL SEAL IN STOCK

序号	类型	规格	丁腈橡胶单价RMB	氟橡胶单价RMB
NO.	TYPE	SPECIFICATION	NBR PRICE	FKM PRICE
4160	TC	70*112*10	30	115
4161	TC	70*112*13	30	115
4162	TC	70*112*14	35	115
4163	TC	70*115*12	38	125
4164	TC	70*115*13	40	135
4165	TC	70*115*15	42	120
4166	TC	70*120*10	40	130
4167	TC	70*120*12	45	135
4168	TC	70*120*13	42.5	135
4169	TC	70*120*15	42.5	135
4170	TC	70*120*16	45	140
4171	TC	70*125*12	45	130
4172	TC	70*125*13	45	130
4173	TC	70*130*12	50	135
4174	TC	70*135*7	50	120
4175	TC	70.3*90.5*12	20	80
4176	TC	70.3*92*8.5	20	71
4177	TC	71*88*8	20	73
4178	TC	71*88*10	20	73
4179	TC	72*82*10	16	67
4180	TC	72*85*10	16.5	68
4181	TC	72*88*8	18	73
4182	TC	72*90*8	18	70
4183	TC	72*90*10	18	70
4184	TC	72*92*9.5	21	71
4185	TC	72*92*12	21	71
4186	TC	72*94*10	20	72
4187	TC	72*94*12	22.5	80
4188	TC	72*95*10	21	74
4189	TC	72*95*12	22	74
4190	TC	72*95*13	23	83
4191	TC	72*96*9	20	75
4192	TC	72*96*10	21	75
4193	TC	72*98*10	21	75
4194	TC	72*100*10	22.5	84
4195	TC	72*100*12	24	84
4196	TC	72*100*13	25	84
4197	TC	72*102*15	30	100
4198	TC	72*105*10	25	88
4199	TC	72*105*12	26	97
4200	TC	72*105*13	27	92
4201	TC	72*105*15	29	105
4202	TC	72*110*12.32	30	110
4203	TC	72*110*13	29	112
4204	TC	72*127*12	46	145
4205	TC	73*88*9	18	73
4206	TC	73*90*7	19.5	70
4207	TC	73*90*7.5	19.5	70
4208	TC	73*90*8	17	70
4209	TC	73*95*7	19	74
4210	TC	73*95*13	23	81
4211	TC	73*97*12	19	95
4212	TC	73*98*12	23.5	85
4213	TC	73*100*14.5	27	100
4214	TC	73.03*90.5*12	20	80
4215	TC	73.1*101.6*14.2	27	100
4216	TC	74*88*8	18	73
4217	TC	74*88*12	20	75
4218	TC	74*90*10	19	70
4219	TC	74*94*10	20	72
4220	TC	74*95*7	20	74
4221	TC	74*95*8	20	74
4222	TC	74*95*12	22	74
4223	TC	74*95*13	23	74
4224	TC	74*96*7	20	75
4225	TC	74*96*12	22.5	75
4226	TC	74*100*12	25	84
4227	TC	74*100*13	25	84
4228	TC	74*102*10	30	88
4229	TC	74*102*13	30	100
4230	TC	74*102*15	30	100
4231	TC	75*85*7	17	68

序号	类型	规格	丁腈橡胶单价RMB	氟橡胶单价RMB
NO.	TYPE	SPECIFICATION	NBR PRICE	FKM PRICE
4232	TC	75*85*8	17	68
4233	TC	75*85*10	17	68
4234	TC	75*90*8	18	70
4235	TC	75*90*10	18	70
4236	TC	75*90*11.5	18	70
4237	TC	75*90*12	18	70
4238	TC	75*90*13	20	70
4239	TC	75*92*10	20	71
4240	TC	75*92*12	21	76
4241	TC	75*93*9	19.5	72
4242	TC	75*94*10	19.8	72
4243	TC	75*95*8	20	74
4244	TC	75*95*9	20	74
4245	TC	75*95*9.5	21	74
4246	TC	75*95*10	19.6	74
4247	TC	75*95*12	20.6	74
4248	TC	75*95*13	23	74
4249	TC	75*95.2*9.5	20	74
4250	TC	75*95.3*13	22.5	92
4251	TC	75*96*5	19	70
4252	TC	75*100*7	25	84
4253	TC	75*100*8	25	84
4254	TC	75*100*8.5	25	84
4255	TC	75*100*10	22	84
4256	TC	75*100*12	22	84
4257	TC	75*100*13	25	87
4258	TC	75*102*10	30	88
4259	TC	75*102*12	30	93
4260	TC	75*102*14	30	100
4261	TC	75*105*10	25	88
4262	TC	75*105*12	25	88
4263	TC	75*105*13	28	103
4264	TC	75*105*15	28	105
4265	TC	75*106*6	30	80
4266	TC	75*106*10	30	95
4267	TC	75*106*13	30	95
4268	TC	75*107*7	30	95
4269	TC	75*108*10	30	100
4270	TC	75*110*10	26.5	100
4271	TC	75*110*12	26.5	100
4272	TC	75*110*13	28	100
4273	TC	75*112*10/17	40	150
4274	TC	75*115*9.5	40	110
4275	TC	75*115*10	36.5	110
4276	TC	75*115*12	37	110
4277	TC	75*115*13	38.5	120
4278	TC	75*118*10	40	120
4279	TC	75*118*12	40	130
4280	TC	75*120*10	40	120
4281	TC	75*120*12	41	130
4282	TC	75*120*13	41	140
4283	TC	75*121*13	43	125
4284	TC	75*125*12	45	125
4285	TC	75*125*13	45	125
4286	TC	75*130*10	50	135
4287	TC	76*92*10	19	71
4288	TC	76*93*10	19.5	72
4289	TC	76*94*12	20	80
4290	TC	76*95*10	19.6	74
4291	TC	76*98*12	23	85
4292	TC	76*100*7	20	84
4293	TC	76*105*12	28	88
4294	TC	76*108*8	30	95
4295	TC	77*91*8	20	71
4296	TC	77*93*10	19.5	72
4297	TC	77*100*11	22	84
4298	TC	77*100*11.5	23	87
4299	TC	78*90*10	18	70
4300	TC	78*90*13	18	70
4301	TC	78*92*10	19	71
4302	TC	78*95*8	18.5	74
4303	TC	78*100*10	22	84

现货油封 OIL SEAL IN STOCK

序号	类型	规格	丁腈橡胶单价RMB	氟橡胶单价RMB
NO.	TYPE	SPECIFICATION	NBR PRICE	FKM PRICE
4304	TC	78*100*13	24	84
4305	TC	78*102*10	30	88
4306	TC	78*105*12	28	88
4307	TC	78*110*8.5	28	100
4308	TC	78*110*12	28	100
4309	TC	78*110*13	30	105
4310	TC	78*115*10	35	120
4311	TC	78*115*12	37	120
4312	TC	78*115*13	38.5	125
4313	TC	78*125*10	45	125
4314	TC	78*135*12	50	135
4315	TC	78*162*16	60	220
4316	TC	78*162.4*16	70	200
4317	TC	78*171*9	120	200
4318	TC	79*95*11	20	74
4319	TC	79*110*10	30	100
4320	TC	79.38*114.71*12.7	45	120
4321	TC	80*90*5	20	70
4322	TC	80*95*8	19	74
4323	TC	80*95*10	19	74
4324	TC	80*95*12	20	74
4325	TC	80*96*9	19.5	75
4326	TC	80*96*10	20.5	75
4327	TC	80*96*12	21	75
4328	TC	80*98*7.5	20	75
4329	TC	80*98*10	20	75
4330	TC	80*100*7	21	84
4331	TC	80*100*8	21	84
4332	TC	80*100*8.5	25	84
4333	TC	80*100*9	21	84
4334	TC	80*100*10	21	84
4335	TC	80*100*12	21.4	84
4336	TC	80*100*13	24	84
4337	TC	80*100*15	30	84
4338	TC	80*105*9	23	88
4339	TC	80*105*10	23	88
4340	TC	80*105*12	23	88
4341	TC	80*105*13	26	88
4342	TC	80*105*14	28	105
4343	TC	80*105*15	30	109
4344	TC	80*108*10	30	95
4345	TC	80*110*10	26.5	100
4346	TC	80*110*10.5	26.5	100
4347	TC	80*110*12	26.5	100
4348	TC	80*110*13	28	100
4349	TC	80*110.05*12	30	110
4350	TC	80*113*12	30	115
4351	TC	80*113*12/17	40	150
4352	TC	80*115*10	35	120
4353	TC	80*115*12	37	120
4354	TC	80*115*13	39	120
4355	TC	80*118*12	40	130
4356	TC	80*120*10	37	120
4357	TC	80*120*12	40	125
4358	TC	80*120*13	41	130
4359	TC	80*125*10	45	125
4360	TC	80*125*12	45	140
4361	TC	80*125*13	45	140
4362	TC	80*130*12	50	135
4363	TC	80*130*13	50	130
4364	TC	80*132*15	52	155
4365	TC	80*140*12	55	150
4366	TC	80*140*13	53	155
4367	TC	80*140*14	55	160
4368	TC	80*160*16	70	200
4369	TC	81*90*5	20	75
4370	TC	81*100*8	30	84
4371	TC	82*95*10	20	74
4372	TC	82*98*9	20	75
4373	TC	82*100*8	22	84
4374	TC	82*100*10	22	84
4375	TC	82*100*13	22	84

序号	类型	规格	丁腈橡胶单价RMB	氟橡胶单价RMB
NO.	TYPE	SPECIFICATION	NBR PRICE	FKM PRICE
4376	TC	82*105*10	25	88
4377	TC	82*105*12	25	88
4378	TC	82*105*13	25	93
4379	TC	82*110*12	26	100
4380	TC	82*115*13	39	125
4381	TC	82*130*15	50	210
4382	TC	82.5*101.6*12.7	22	100
4383	TC	82.5*107.9*12.7	30	105
4384	TC	83*97*7	20	75
4385	TC	83*100*9	23	84
4386	TC	83*110*13	30	100
4387	TC	83*118*9	40	110
4388	TC	84*100*10	23	84
4389	TC	84*104*8.5	30	88
4390	TC	84*104*9	30	88
4391	TC	84*104*10	30	88
4392	TC	84*104*11	30	88
4393	TC	84.1*108*14	30	105
4394	TC	84.1*111.2*12.7	35	115
4395	TC	84.15*111.3*12.7	35	115
4396	TC	84.5*97.3*5	25	75
4397	TC	85*95*10	20	84
4398	TC	85*100*9	23	84
4399	TC	85*100*10	23	84
4400	TC	85*100*12	23.5	84
4401	TC	85*100*13	25	84
4402	TC	85*102*13	30	92
4403	TC	85*103*8	30	88
4404	TC	85*103*10	26	88
4405	TC	85*105*8	23	88
4406	TC	85*105*9	30	88
4407	TC	85*105*10	23	88
4408	TC	85*105*12	23	88
4409	TC	85*105*13	23	88
4410	TC	85*108*12	30	95
4411	TC	85*110*8	27	100
4412	TC	85*110*10	27	100
4413	TC	85*110*12	26.5	100
4414	TC	85*110*13	26.5	100
4415	TC	85*115*10	35	110
4416	TC	85*115*12	37	120
4417	TC	85*115*13	38.5	120
4418	TC	85*115*15	40	120
4419	TC	85*120*10	37	120
4420	TC	85*120*12	36	125
4421	TC	85*120*13	40	125
4422	TC	85*125*10	40	125
4423	TC	85*125*12	42	125
4424	TC	85*125*13	45.5	130
4425	TC	85*125*14	46	140
4426	TC	85*127*13	46	145
4427	TC	85*130*10	45	130
4428	TC	85*130*12	45.5	130
4429	TC	85*130*13	46	130
4430	TC	85*132*10	50	135
4431	TC	85*135*12	50	145
4432	TC	85*135*13	50	145
4433	TC	85*140*12	55	145
4434	TC	85*140*13	55	160
4435	TC	85*145*13	60	160
4436	TC	85*150*12	65	180
4437	TC	85*150*14	65	180
4438	TC	85*160*13	70	200
4439	TC	85.7*114.2*11.2	40	120
4440	TC	86*100*9	25	84
4441	TC	86*100*10	25	84
4442	TC	86*103*8	30	88
4443	TC	86*103*9	30	88
4444	TC	86*104*9	30	88
4445	TC	87*100*6	21	70
4446	TC	87*100*8	30	84
4447	TC	87*114*13	35	120

现货油封 OIL SEAL IN STOCK

序号	类型	规格	丁腈橡胶单价RMB	氟橡胶单价RMB
NO.	TYPE	SPECIFICATION	NBR PRICE	FKM PRICE
4448	TC	87*114.3*13	40	120
4449	TC	87*114.7*13	40	120
4450	TC	87*115*13	40	120
4451	TC	87.3*114.3*12.7	35	120
4452	TC	87.71*114.55*12.7	40	120
4453	TC	88*104*10	30	88
4454	TC	88*106*8	30	95
4455	TC	88*106*8.5	30	95
4456	TC	88*106*10	30	95
4457	TC	88*108*11	30	95
4458	TC	88*108*11.11	30	95
4459	TC	88*110*12	30	100
4460	TC	88*110*13	30	105
4461	TC	88*115*13	40	120
4462	TC	88*125*12	42.5	125
4463	TC	88.9*114.3*9.52	35	120
4464	TC	89*98*6	19.5	95
4465	TC	89*109*9	30	95
4466	TC	90*100*7	28	84
4467	TC	90*100*9	28	84
4468	TC	90*100*10	28	84
4469	TC	90*100*12	28	84
4470	TC	90*104*10	30	88
4471	TC	90*105*10	28	88
4472	TC	90*105*12	23	88
4473	TC	90*105*13	30	96
4474	TC	90*105*15	30	105
4475	TC	90*108*10	30	95
4476	TC	90*109*9	30	95
4477	TC	90*110*5.5	26.5	85
4478	TC	90*110*7	30	90
4479	TC	90*110*8	26.5	95
4480	TC	90*110*9	26.5	100
4481	TC	90*110*10	26.5	100
4482	TC	90*110*12	26.5	100
4483	TC	90*110*13	27	100
4484	TC	90*110*14	30	100
4485	TC	90*110*15	35	110
4486	TC	90*110*8/10	27	125
4487	TC	90*110.7*13	35	110
4488	TC	90*112*12	30	115
4489	TC	90*115*8	35	100
4490	TC	90*115*10	35	120
4491	TC	90*115*12	33.5	120
4492	TC	90*115*13	38	120
4493	TC	90*115*15	38	120
4494	TC	90*118*10	40	120
4495	TC	90*118*11.3	40	120
4496	TC	90*118*12	40	120
4497	TC	90*120*10	36.5	120
4498	TC	90*120*12	38	120
4499	TC	90*120*13	40	130
4500	TC	90*120*14	40	130
4501	TC	90*120*15	40	135
4502	TC	90*120*20	70	160
4503	TC	90*125*10	40	125
4504	TC	90*125*12	42	125
4505	TC	90*125*13	43.5	125
4506	TC	90*125*15	45	145
4507	TC	90*125.25*10	40	125
4508	TC	90*127*13	45.5	145
4509	TC	90*130*10	45	120
4510	TC	90*130*12	44.5	130
4511	TC	90*130*13	46.5	130
4512	TC	90*130*15	46.5	130
4513	TC	90*135*12	46	135
4514	TC	90*135*13	49	140
4515	TC	90*135*15	51.5	150
4516	TC	90*140*12	50	150
4517	TC	90*140*13	50	150
4518	TC	90*140*14	50	155
4519	TC	90*145*12	60	145

序号	类型	规格	丁腈橡胶单价RMB	氟橡胶单价RMB
NO.	TYPE	SPECIFICATION	NBR PRICE	FKM PRICE
4520	TC	90*145*14	60	150
4521	TC	90*150*12	55	170
4522	TC	90*160*10	120	190
4523	TC	90*160*13	120	200
4524	TC	90*180*12	150	250
4525	TC	90.5*114*12	35	120
4526	TC	91*107*7	30	95
4527	TC	91*111*9	35	115
4528	TC	91*114*9	35	120
4529	TC	92*100*10	28	84
4530	TC	92*105*10	23	88
4531	TC	92*105*13	30	90
4532	TC	92*108*9.5	30	95
4533	TC	92*110*10	30	100
4534	TC	92*120*12	37	120
4535	TC	92*125*12	42	125
4536	TC	93*108*7	30	95
4537	TC	93*113*13	35	115
4538	TC	93*114*13	35	120
4539	TC	94*111.5*9.5	35	115
4540	TC	94*112*9.5	30	115
4541	TC	94*112*12	30	115
4542	TC	94*114.3*13	38	120
4543	TC	94*114.5*15.5	40	140
4544	TC	94*125*12	42	125
4545	TC	95*100*10	28	84
4546	TC	95*105*10	28	88
4547	TC	95*105*13	30	88
4548	TC	95*110*10	27	100
4549	TC	95*110*11	28	100
4550	TC	95*110*12	26.5	100
4551	TC	95*110*13	30	100
4552	TC	95*112*12	30	115
4553	TC	95*115*8.5	38	100
4554	TC	95*115*9.5	40	110
4555	TC	95*115*10	40	100
4556	TC	95*115*12	35	120
4557	TC	95*115*13	36	120
4558	TC	95*117*12	40	120
4559	TC	95*118*10	40	120
4560	TC	95*118*10.5	40	120
4561	TC	95*118*12	40	120
4562	TC	95*120*8	35	100
4563	TC	95*120*10	35	120
4564	TC	95*120*12	34.5	120
4565	TC	95*120*13	39	120
4566	TC	95*120*14	39	125
4567	TC	95*125*10	40	125
4568	TC	95*125*12	38.3	125
4569	TC	95*125*13	43.5	125
4570	TC	95*125*15	46	145
4571	TC	95*130*10	41	120
4572	TC	95*130*12	43	130
4573	TC	95*130*13	45	140
4574	TC	95*130*14	46.5	145
4575	TC	95*130*15	50	150
4576	TC	95*132*14	48	135
4577	TC	95*132*11.5/21	50	202
4578	TC	95*135*10	44	135
4579	TC	95*135*12	45	135
4580	TC	95*135*13	47.5	135
4581	TC	95*140*12	50	140
4582	TC	95*140*13	50	140
4583	TC	95*145*10	50	145
4584	TC	95*145*12	60	145
4585	TC	95*145*13	62	155
4586	TC	95*150*12	55	170
4587	TC	95*170*12	120	220
4588	TC	95*170*13	120	220
4589	TC	95.25*114.3*12.7	38	120
4590	TC	95.25*114.5*20.32	60	150
4591	TC	95.3*114.29*11.8	35	120

现货油封 OIL SEAL IN STOCK

序号	类型	规格	丁腈橡胶单价RMB	氟橡胶单价RMB
NO.	TYPE	SPECIFICATION	NBR PRICE	FKM PRICE
4592	TC	96*115*12	40	120
4593	TC	96*120*12	40	120
4594	TC	97*116*10	45	120
4595	TC	98*116*10	40	120
4596	TC	98*120*7	35	100
4597	TC	98*120*12	36	120
4598	TC	98*120*13	37	120
4599	TC	98*127*12	45	120
4600	TC	98*130*12	43.5	130
4601	TC	98*130*13	45	130
4602	TC	98.1*136.5*12.7	46	140
4603	TC	100*110*12	30	100
4604	TC	100*114*7	35	120
4605	TC	100*115*9	40	100
4606	TC	100*115*10	40	110
4607	TC	100*115*12	40	110
4608	TC	100*115*13	45	120
4609	TC	100*118*10	40	120
4610	TC	100*118*12	40	120
4611	TC	100*120*8	40	105
4612	TC	100*120*10	36	110
4613	TC	100*120*11	36	120
4614	TC	100*120*12	35	125
4615	TC	100*120*13	36	125
4616	TC	100*124*13	40	125
4617	TC	100*125*8	40	115
4618	TC	100*125*10	40	125
4619	TC	100*125*12	36.7	125
4620	TC	100*125*13	41	125
4621	TC	100*125*15	46	130
4622	TC	100*128*15	48	145
4623	TC	100*130*10	41	120
4624	TC	100*130*12	40	130
4625	TC	100*130*13	42	130
4626	TC	100*130*14	45	130
4627	TC	100*130*15	46	130
4628	TC	100*130*16	46	145
4629	TC	100*135*10	42	135
4630	TC	100*135*12	45.5	135
4631	TC	100*135*13	46.5	135
4632	TC	100*135*14	48.5	145
4633	TC	100*135*15	51	145
4634	TC	100*140*10	45	140
4635	TC	100*140*12	48	150
4636	TC	100*140*13	48	150
4637	TC	100*140*14	48	150
4638	TC	100*140*15	53	155
4639	TC	100*145*14	55	157
4640	TC	100*145*15	55	160
4641	TC	100*150*10	50	150
4642	TC	100*150*12	52	160
4643	TC	100*150*13	55	165
4644	TC	100*150*14	56	165
4645	TC	100*150*15	60	190
4646	TC	100*155*12	60	175
4647	TC	100*155*14	60	185
4648	TC	100*155*16	63	195
4649	TC	100*160*12	59	195
4650	TC	100*160*14	65	200
4651	TC	100*160*15	65	210
4652	TC	100*180*15	150	260
4653	TC	100*185*13	170	340
4654	TC	100*190*15	180	370
4655	TC	100*200*15	180	375
4656	TC	101*114*10	35	120
4657	TC	101*130*13	43.5	145
4658	TC	101.6*114.3*6.35	35	120
4659	TC	101.6*127*12.7	40	130
4660	TC	102*125*13	45	125
4661	TC	102*149*15.5	70	160
4662	TC	103*130*13	46	145
4663	TC	104*134*13	50	135

序号	类型	规格	丁腈橡胶单价RMB	氟橡胶单价RMB
NO.	TYPE	SPECIFICATION	NBR PRICE	FKM PRICE
4664	TC	104*135*9	42	120
4665	TC	105*110*14	30	110
4666	TC	105*120*8	40	100
4667	TC	105*120*10	40	100
4668	TC	105*120*11	35	110
4669	TC	105*120*12	40	120
4670	TC	105*120*13	40	120
4671	TC	105*125*5.5	40	100
4672	TC	105*125*10	38	125
4673	TC	105*125*12	39.5	125
4674	TC	105*125*13	40	125
4675	TC	105*126*13	45	130
4676	TC	105*130*8	50	110
4677	TC	105*130*10	45	130
4678	TC	105*130*11	45	130
4679	TC	105*130*11.2	45	130
4680	TC	105*130*12	40	130
4681	TC	105*130*13	43.5	130
4682	TC	105*130*14	44.5	130
4683	TC	105*130*15	47	135
4684	TC	105*130*18	50	165
4685	TC	105*135*9	40	120
4686	TC	105*135*12	42.5	135
4687	TC	105*135*13	50	135
4688	TC	105*135*14	50	140
4689	TC	105*135*15	50	140
4690	TC	105*136*13	46	140
4691	TC	105*138*12	45.5	140
4692	TC	105*140*12	45	140
4693	TC	105*140*13	49	145
4694	TC	105*140*14	52	160
4695	TC	105*140*15	52	160
4696	TC	105*145*12	49	145
4697	TC	105*145*14	52	150
4698	TC	105*145*15	55	160
4699	TC	105*150*13	55	165
4700	TC	105*150*14	56	175
4701	TC	105*150*15	58	180
4702	TC	105*155*14	60	185
4703	TC	105*160*12	62	185
4704	TC	106*126*12	45	125
4705	TC	106*138*12	45.5	140
4706	TC	107*127*13	45	130
4707	TC	107*136*12	45	140
4708	TC	108*125*7	35	110
4709	TC	108*130*8	36	110
4710	TC	108*135*8	40	120
4711	TC	108*140*14	50	155
4712	TC	108*170*15	110	230
4713	TC	108*180*17	150	280
4714	TC	108.5*138*12	45.5	195
4715	TC	109*130*14.5	43	140
4716	TC	110*125*10	40	120
4717	TC	110*125*12	36	125
4718	TC	110*125*13	40	125
4719	TC	110*130*8	38	110
4720	TC	110*130*10	40	120
4721	TC	110*130*12	38	130
4722	TC	110*130*13	43	130
4723	TC	110*130*14	43	135
4724	TC	110*130*14.5	45	135
4725	TC	110*130*15	45	135
4726	TC	110*132*7	42	120
4727	TC	110*135*9	40	125
4728	TC	110*135*10	40	135
4729	TC	110*135*12	40	135
4730	TC	110*135*13	45.5	135
4731	TC	110*135*14	46.5	140
4732	TC	110*138*12	45	140
4733	TC	110*140*10	42	135
4734	TC	110*140*12	43	140
4735	TC	110*140*13	43	145

现货油封 OIL SEAL IN STOCK

序号	类型	规格	丁腈橡胶单价RMB	氟橡胶单价RMB
NO.	TYPE	SPECIFICATION	NBR PRICE	FKM PRICE
4736	TC	110*140*14	46	150
4737	TC	110*140*15	50	160
4738	TC	110*142*12	46	145
4739	TC	110*142*14	51	145
4740	TC	110*145*12	48	145
4741	TC	110*145*13	49	145
4742	TC	110*145*14	54	165
4743	TC	110*145*15	49	165
4744	TC	110*146*14	55	150
4745	TC	110*146*15	50	160
4746	TC	110*150*12	50	155
4747	TC	110*150*13	52	155
4748	TC	110*150*14	56	160
4749	TC	110*150*15	56	170
4750	TC	110*150*18	60	200
4751	TC	110*154*34	180	250
4752	TC	110*160*12	62	185
4753	TC	110*160*13	62	185
4754	TC	110*160*14	63	210
4755	TC	110*160*16	63	210
4756	TC	110*170*12	110	210
4757	TC	110*170*13	100	210
4758	TC	110*170*15	110	210
4759	TC	110*200*12	180	375
4760	TC	112*135*13	44	140
4761	TC	112*140*12	48	140
4762	TC	112*140*13	50	140
4763	TC	112*140*14	50	150
4764	TC	113*145*14	55	165
4765	TC	114*135*13	44	135
4766	TC	114*145*12	48	150
4767	TC	114*145*14	50	145
4768	TC	114*145*15	55	150
4769	TC	114*146*13	50	150
4770	TC	114.3*139.7*12.7	45.5	150
4771	TC	115*130*12	42	120
4772	TC	115*130*13	42	125
4773	TC	115*130*14	42	130
4774	TC	115*135*13	41	135
4775	TC	115*135*14	41	135
4776	TC	115*140*12	42	140
4777	TC	115*140*13	47	140
4778	TC	115*140*14	48	145
4779	TC	115*140*15	50	150
4780	TC	115*140*16	52	155
4781	TC	115*145*12	50	145
4782	TC	115*145*13	49	145
4783	TC	115*145*14	48	145
4784	TC	115*145*15	50	150
4785	TC	115*145*16	48	160
4786	TC	115*146*16	50	160
4787	TC	115*150*12	50	150
4788	TC	115*150*14	47	155
4789	TC	115*150*15	50	160
4790	TC	115*150*16	55	160
4791	TC	115*155*10	60	170
4792	TC	115*160*13	55	185
4793	TC	115*160*14	60	185
4794	TC	115*160*15	62	200
4795	TC	115*180*15	120	250
4796	TC	116*160*13	55	190
4797	TC	117.7*142.5*12.7	60	145
4798	TC	118*148*15	50	160
4799	TC	118*150*12	50	150
4800	TC	119*141*12	55	140
4801	TC	119.25*152.55*22	100	210
4802	TC	120*139*13	45	140
4803	TC	120*140*8	42	125
4804	TC	120*140*10	42	130
4805	TC	120*140*12	43	135
4806	TC	120*140*13	43	140
4807	TC	120*140*14	45	145

序号	类型	规格	丁腈橡胶单价RMB	氟橡胶单价RMB
NO.	TYPE	SPECIFICATION	NBR PRICE	FKM PRICE
4808	TC	120*140*15	45	150
4809	TC	120*145*9	49	140
4810	TC	120*145*10	46	145
4811	TC	120*145*12	46	145
4812	TC	120*145*13	48	145
4813	TC	120*145*15	49	150
4814	TC	120*146*13	49	150
4815	TC	120*146.5*13	50	160
4816	TC	120*150*10	47	150
4817	TC	120*150*12	47	150
4818	TC	120*150*13	47	165
4819	TC	120*150*14	47.9	165
4820	TC	120*150*15	53	165
4821	TC	120*150*16	54	175
4822	TC	120*152*15	55	175
4823	TC	120*155*12	52	155
4824	TC	120*155*14	55	180
4825	TC	120*155*15	60	185
4826	TC	120*155*16	60	185
4827	TC	120*160*12	55	175
4828	TC	120*160*13	55	175
4829	TC	120*160*14	56	175
4830	TC	120*160*15	62	195
4831	TC	120*160*16	62	195
4832	TC	120*165*13	60	180
4833	TC	120*165*14	65	190
4834	TC	120*170*12	80	190
4835	TC	120*170*13	78	190
4836	TC	120*170*14	78	200
4837	TC	120*170*15	78	210
4838	TC	120*180*12	90	240
4839	TC	120*180*13	80	250
4840	TC	120*180*14	80	250
4841	TC	120*180*15	80	260
4842	TC	121*150*13	50	160
4843	TC	122*140*13	43	140
4844	TC	122*141*12	55	140
4845	TC	122*150*13	60	150
4846	TC	122*152.3*23	100	210
4847	TC	124*146*14	49	150
4848	TC	125*140*10	43	130
4849	TC	125*140*12	43	140
4850	TC	125*140*13	43	140
4851	TC	125*145*12	46	145
4852	TC	125*145*13	46	145
4853	TC	125*145*14	47	145
4854	TC	125*146*10	50	150
4855	TC	125*146*14	50	150
4856	TC	125*146.5*13	50	160
4857	TC	125*148*9	48	150
4858	TC	125*150*10	50	150
4859	TC	125*150*12	47	150
4860	TC	125*150*13	50	150
4861	TC	125*150*14	50	150
4862	TC	125*150*15	47	160
4863	TC	125*152*12	50	175
4864	TC	125*152*13	50	175
4865	TC	125*152*15	50	175
4866	TC	125*155*12	52	155
4867	TC	125*155*14	54	165
4868	TC	125*159*7	52	175
4869	TC	125*159*13	55	175
4870	TC	125*160*12	55	175
4871	TC	125*160*13	58	175
4872	TC	125*160*14	55	175
4873	TC	125*160*15	61	185
4874	TC	125*165*13	62	180
4875	TC	125*165*14	62	180
4876	TC	125*165*15	63	180
4877	TC	125*170*13	78	190
4878	TC	125*170*22	120	250
4879	TC	125*175*13	78	200

现货油封 OIL SEAL IN STOCK

序号	类型	规格	丁腈橡胶单价RMB	氟橡胶单价RMB
NO.	TYPE	SPECIFICATION	NBR PRICE	FKM PRICE
4880	TC	125*200*15	180	370
4881	TC	126*146*10	47	150
4882	TC	126*146*13	50	150
4883	TC	127*146*10	47	150
4884	TC	127*147*11	50	150
4885	TC	127*150*14	51	150
4886	TC	127*152.4*12.7	80	155
4887	TC	127*156*12	55	175
4888	TC	127*156*14	55	175
4889	TC	128*148*13	48	150
4890	TC	129*146*14	50	150
4891	TC	129.5*157*3.5	55	175
4892	TC	130*140*12	55	140
4893	TC	130*140*13	55	140
4894	TC	130*145*11	50	140
4895	TC	130*145*13	50	145
4896	TC	130*145*18	47	200
4897	TC	130*146*14	50	150
4898	TC	130*148*15	50	160
4899	TC	130*150*8	47	140
4900	TC	130*150*10	50	150
4901	TC	130*150*12	47	150
4902	TC	130*150*13	50	150
4903	TC	130*150*14	50	155
4904	TC	130*150*15	48	175
4905	TC	130*150*16	60	175
4906	TC	130*153*12	50	155
4907	TC	130*154*13.8	55	175
4908	TC	130*154*16	60	180
4909	TC	130*154*18	90	190
4910	TC	130*155*10	52	155
4911	TC	130*155*12	55	165
4912	TC	130*155*13	52	165
4913	TC	130*155*14	53	165
4914	TC	130*160*10	55	175
4915	TC	130*160*12	52	175
4916	TC	130*160*13	55	175
4917	TC	130*160*14	55	175
4918	TC	130*160*15	53	180
4919	TC	130*162*15	62	180
4920	TC	130*165*12	60	180
4921	TC	130*165*13	60	180
4922	TC	130*165*14	60	180
4923	TC	130*165*15	62	180
4924	TC	130*168*13	60	180
4925	TC	130*170*12	65	180
4926	TC	130*170*13	65	180
4927	TC	130*170*14	65	190
4928	TC	130*170*15	65	190
4929	TC	130*170*16	70	195
4930	TC	130*180*13	80	200
4931	TC	130*180*14	80	220
4932	TC	130*190*12	100	290
4933	TC	130*190*15	100	325
4934	TC	130*200*12	180	370
4935	TC	135*150*10	48	150
4936	TC	135*150*12	48	150
4937	TC	135*150*14	48	150
4938	TC	135*155*12	52	155
4939	TC	135*155*13	52	165
4940	TC	135*155*14	52	165
4941	TC	135*158*13	55	175
4942	TC	135*159*15	55	185
4943	TC	135*160*12	55	175
4944	TC	135*160*13	55	175
4945	TC	135*160*14	55	180
4946	TC	135*160*15	55	175
4947	TC	135*160*16	58	180
4948	TC	135*162*13	60	180
4949	TC	135*165*12	60	180
4950	TC	135*165*13	60	180
4951	TC	135*165*14	60	180

序号	类型	规格	丁腈橡胶单价RMB	氟橡胶单价RMB
NO.	TYPE	SPECIFICATION	NBR PRICE	FKM PRICE
4952	TC	135*165*15	60	180
4953	TC	135*165*16	62	180
4954	TC	135*168*16	65	190
4955	TC	135*170*12	60	180
4956	TC	135*170*13	60	180
4957	TC	135*170*14	62	185
4958	TC	135*170*15	63	190
4959	TC	135*175*12	65	200
4960	TC	135*175*13	65	200
4961	TC	135*175*15	68	200
4962	TC	135*180*14.5	120	230
4963	TC	135*190*15	150	325
4964	TC	135*192*16	150	325
4965	TC	135*200*15	180	370
4966	TC	137*160*12	55	175
4967	TC	138*150*15	50	160
4968	TC	138*152*12	60	155
4969	TC	138*160*12	55	175
4970	TC	138*160*15	59	175
4971	TC	138*171.2*15	110	200
4972	TC	139.7*171.4*15.8	75	200
4973	TC	140*155*12	55	155
4974	TC	140*158*10	55	175
4975	TC	140*158*13	55	175
4976	TC	140*160*10	55	170
4977	TC	140*160*12	55	175
4978	TC	140*160*13	56	175
4979	TC	140*160*14	52	175
4980	TC	140*160*15	55	175
4981	TC	140*164*16	60	180
4982	TC	140*165*10	60	180
4983	TC	140*165*12	60	180
4984	TC	140*165*13	56	180
4985	TC	140*165*14	60	180
4986	TC	140*165*15	60	180
4987	TC	140*167*12	60	180
4988	TC	140*167*15	63	180
4989	TC	140*168*13	60	180
4990	TC	140*170*10	60	180
4991	TC	140*170*12	60	180
4992	TC	140*170*13	60	180
4993	TC	140*170*14	61	185
4994	TC	140*170*15	63	210
4995	TC	140*170*16	68	210
4996	TC	140*170*18	70	220
4997	TC	140*172*15	63	200
4998	TC	140*175*13	65	200
4999	TC	140*175*15	67	200
5000	TC	140*175*16	67	210
5001	TC	140*180*12	80	190
5002	TC	140*180*13	72	195
5003	TC	140*180*14	75	200
5004	TC	140*180*15	75	210
5005	TC	140*180*16	75	230
5006	TC	140*185*16	88	260
5007	TC	140*190*13	120	325
5008	TC	140*190*14	120	325
5009	TC	140*200*12	180	370
5010	TC	140*215*15	150	340
5011	TC	140*250*20	200	500
5012	TC	142*168*15	60	180
5013	TC	142*168*16	64	190
5014	TC	142*170*15	63	190
5015	TC	143*179*14	120	210
5016	TC	144*160*12	55	175
5017	TC	144*175*15	70	200
5018	TC	145*160*14	55	175
5019	TC	145*160*15	52	175
5020	TC	145*165*12	60	180
5021	TC	145*165*13	65	180
5022	TC	145*165*14	60	180
5023	TC	145*165*15	60	180

现货油封 OIL SEAL IN STOCK

序号	类型	规格	丁腈橡胶单价RMB	氟橡胶单价RMB
NO.	TYPE	SPECIFICATION	NBR PRICE	FKM PRICE
5024	TC	145*167*13	60	180
5025	TC	145*167*15	60	180
5026	TC	145*168*13	60	180
5027	TC	145*170*12	63	185
5028	TC	145*170*13	63	185
5029	TC	145*170*15	63	190
5030	TC	145*170*22	120	230
5031	TC	145*175*12	70	200
5032	TC	145*175*13	70	200
5033	TC	145*175*14	65	210
5034	TC	145*175*15	66	210
5035	TC	145*175*17	66	210
5036	TC	145*180*12	75	200
5037	TC	145*180*13	75	210
5038	TC	145*180*14	75	215
5039	TC	145*180*15	75	215
5040	TC	145*180*16	80	220
5041	TC	145*185*15	88	260
5042	TC	145*230*17	160	455
5043	TC	146*164*14	60	180
5044	TC	146*170*18	63	180
5045	TC	148*170*12	60	180
5046	TC	148*170*13	60	180
5047	TC	148*170*15	63	180
5048	TC	149*162.5*7	60	200
5049	TC	149*165*11.5	65	180
5050	TC	150*165*12	60	180
5051	TC	150*168*13	60	180
5052	TC	150*170*8	60	170
5053	TC	150*170*12	63	175
5054	TC	150*170*13	60	175
5055	TC	150*170*14	60	175
5056	TC	150*170*15	63	180
5057	TC	150*172*12	63	200
5058	TC	150*172*13	63	200
5059	TC	150*172*15	63	200
5060	TC	150*172*17	75	200
5061	TC	150*175*10	70	180
5062	TC	150*175*13	70	180
5063	TC	150*175*14	70	200
5064	TC	150*175*15	70	200
5065	TC	150*178*13	70	195
5066	TC	150*180*8	75	220
5067	TC	150*180*12	80	180
5068	TC	150*180*13	80	195
5069	TC	150*180*14	75	200
5070	TC	150*180*15	75	210
5071	TC	150*180*16	75	210
5072	TC	150*180*18	75	220
5073	TC	150*185*15	85	270
5074	TC	150*185*16	90	290
5075	TC	150*185*18	92	300
5076	TC	150*190*12	90	260
5077	TC	150*190*15	90	285
5078	TC	150*190*16	92	290
5079	TC	150*200*13	130	360
5080	TC	150*210*15	130	360
5081	TC	150*225*12	160	360
5082	TC	150*225*15	160	360
5083	TC	152*174*15	75	200
5084	TC	152*180*15	75	220
5085	TC	153*175*13	70	200
5086	TC	153*180*15	80	200
5087	TC	154*172*14	63	200
5088	TC	154*175*13	70	200
5089	TC	154*175*14	70	200
5090	TC	154*180*18	75	230
5091	TC	155*172*14	63	200
5092	TC	155*174*12	63	200
5093	TC	155*175*13	75	180
5094	TC	155*178*12	70	195
5095	TC	155*178*13	70	195

序号	类型	规格	丁腈橡胶单价RMB	氟橡胶单价RMB
NO.	TYPE	SPECIFICATION	NBR PRICE	FKM PRICE
5096	TC	155*178*15	75	200
5097	TC	155*180*10	80	185
5098	TC	155*180*12	80	190
5099	TC	155*180*13	80	195
5100	TC	155*180*15	75	200
5101	TC	155*185*14	82	255
5102	TC	155*185*15	85	270
5103	TC	155*185*16	85	275
5104	TC	155*185*18	90	290
5105	TC	155*190*13	90	260
5106	TC	155*190*14	85	270
5107	TC	155*190*15	86	285
5108	TC	155.58*184.15*12.7	90	260
5109	TC	158*180*15	80	200
5110	TC	160*180*10	80	170
5111	TC	160*180*12	80	175
5112	TC	160*180*13	80	180
5113	TC	160*180*14	80	180
5114	TC	160*180*15	75	185
5115	TC	160*182*15	80	230
5116	TC	160*182*18	90	250
5117	TC	160*185*10	76	215
5118	TC	160*185*12	79	240
5119	TC	160*185*13	79	240
5120	TC	160*185*14	80	250
5121	TC	160*185*15	80	255
5122	TC	160*188*12.7	90	250
5123	TC	160*190*12	80	255
5124	TC	160*190*13	80	255
5125	TC	160*190*14	82	275
5126	TC	160*190*15	86	285
5127	TC	160*190*16	86	290
5128	TC	160*190*18	90	295
5129	TC	160*195*15	85	280
5130	TC	160*200*12	85	270
5131	TC	160*200*13	92	300
5132	TC	160*200*14	92	300
5133	TC	160*200*15	95	320
5134	TC	160*200*16	93	320
5135	TC	160*215*15	150	340
5136	TC	160*225*14	160	370
5137	TC	162*190*12	82	240
5138	TC	162*195*15	85	280
5139	TC	165*180*13	75	180
5140	TC	165*180*14	72	180
5141	TC	165*180*15	80	190
5142	TC	165*185*14	80	260
5143	TC	165*185*15	82	265
5144	TC	165*186*12	80	225
5145	TC	165*186*14	90	225
5146	TC	165*186*16	90	235
5147	TC	165*188*14	90	250
5148	TC	165*190*13	82	240
5149	TC	165*190*14	85	260
5150	TC	165*190*15	83	265
5151	TC	165*190*15.5	90	280
5152	TC	165*190*17	90	290
5153	TC	165*195*14	90	280
5154	TC	165*195*15	90	300
5155	TC	165*200*15	92	305
5156	TC	170*190*7	90	220
5157	TC	170*190*8.5	90	230
5158	TC	170*190*10	90	230
5159	TC	170*190*13	90	265
5160	TC	170*190*14	90	265
5161	TC	170*190*15	90	265
5162	TC	170*190*18	90	290
5163	TC	170*195*15	85	280
5164	TC	170*195*18	90	300
5165	TC	170*200*12	85	270
5166	TC	170*200*13	85	280
5167	TC	170*200*15	82	300

现货油封 OIL SEAL IN STOCK

序号	类型	规格	丁腈橡胶单价RMB	氟橡胶单价RMB
NO.	TYPE	SPECIFICATION	NBR PRICE	FKM PRICE
5168	TC	170*200*16	91	300
5169	TC	170*200*18	96	320
5170	TC	170*205*15	98	310
5171	TC	170*205*17	98	310
5172	TC	170*210*15	102	335
5173	TC	170*210*16	105	340
5174	TC	170*210*24	140	410
5175	TC	170*215*15	105	330
5176	TC	170*220*15	110	355
5177	TC	170*220*16	115	360
5178	TC	170*220*18	120	390
5179	TC	175*190*15	80	270
5180	TC	175*195*15	80	280
5181	TC	175*200*12	82	280
5182	TC	175*200*13	83	280
5183	TC	175*200*15	85	285
5184	TC	175*205*15	92	310
5185	TC	175*210*13	100	310
5186	TC	175*210*14	100	315
5187	TC	175*210*15	105	320
5188	TC	175*215*15	105	330
5189	TC	175*220*15	110	350
5190	TC	175*220*18	115	375
5191	TC	175*230*20	150	455
5192	TC	177*208*15	95	350
5193	TC	180*200*12	82	250
5194	TC	180*200*14	82	255
5195	TC	180*200*15	82	270
5196	TC	180*200*16	90	280
5197	TC	180*200*18	90	285
5198	TC	180*205*12	90	270
5199	TC	180*205*14	90	275
5200	TC	180*205*15	95	300
5201	TC	180*208*15	95	350
5202	TC	180*210*13	88	275
5203	TC	180*210*15	90	310
5204	TC	180*210*16	100	310
5205	TC	180*210*18	102	335
5206	TC	180*215*13	100	300
5207	TC	180*215*14	100	315
5208	TC	180*215*15	100	315
5209	TC	180*215*16	105	320
5210	TC	180*215*18	110	350
5211	TC	180*220*15	105	340
5212	TC	180*220*16	110	350
5213	TC	180*220*18	110	355
5214	TC	180*230*15	130	450
5215	TC	180*230*18	130	450
5216	TC	180*240*20	140	480
5217	TC	184.2*222.3*15.9	120	360
5218	TC	185*205*13	90	300
5219	TC	185*210*13	88	280
5220	TC	185*210*15	92	290
5221	TC	185*215*15	95	310
5222	TC	185*215*16	100	320
5223	TC	185*220*15	105	325
5224	TC	185*230*16	115	385
5225	TC	188*202*10	90	320
5226	TC	190*210*10	85	250
5227	TC	190*210*11	85	270
5228	TC	190*210*15	90	280
5229	TC	190*215*15	100	320
5230	TC	190*215*16	100	320
5231	TC	190*215*18	100	330
5232	TC	190*220*12	95	310
5233	TC	190*220*14	105	315
5234	TC	190*220*15	95	325
5235	TC	190*220*16	100	330
5236	TC	190*220*18	105	360
5237	TC	190*225*12	100	310
5238	TC	190*225*15	110	350
5239	TC	190*225*16	115	355

序号	类型	规格	丁腈橡胶单价RMB	氟橡胶单价RMB
NO.	TYPE	SPECIFICATION	NBR PRICE	FKM PRICE
5240	TC	190*225*18	125	390
5241	TC	190*230*15	110	375
5242	TC	190*230*16	110	375
5243	TC	190*230*18	115	385
5244	TC	190*240*15	120	385
5245	TC	190*240*18	123	410
5246	TC	190*250*15	128	420
5247	TC	195*215*15	120	320
5248	TC	195*220*15	110	330
5249	TC	195*220*16	110	330
5250	TC	195*225*16	115	340
5251	TC	195*230*15	110	335
5252	TC	195*230*16	110	360
5253	TC	195*230*20	125	410
5254	TC	195*235*15	115	365
5255	TC	195*235*16	115	365
5256	TC	195*240*15	120	400
5257	TC	196*226*15	110	330
5258	TC	200*220*12	95	320
5259	TC	200*225*15	95	310
5260	TC	200*230*12	99	320
5261	TC	200*230*13	100	330
5262	TC	200*230*15	100	350
5263	TC	200*230*16	105	350
5264	TC	200*230*18	105	350
5265	TC	200*232*14	100	350
5266	TC	200*235*12	100	330
5267	TC	200*235*13	105	340
5268	TC	200*235*15	105	340
5269	TC	200*235*16	110	345
5270	TC	200*235*18	115	375
5271	TC	200*240*12	110	345
5272	TC	200*240*15	112	410
5273	TC	200*240*16	115	410
5274	TC	200*240*18	120	415
5275	TC	200*240*20	125	420
5276	TC	200*250*15	128	425
5277	TC	200*250*16	128	430
5278	TC	200*250*18	128	455
5279	TC	200*250*20	128	460
5280	TC	200*260*18	180	480
5281	TC	203.2*241.3*18	150	400
5282	TC	205*225*18	110	320
5283	TC	205*230*16	100	345
5284	TC	205*235*18	115	375
5285	TC	205*240*12	110	385
5286	TC	205*240*16	115	410
5287	TC	205*245*18	120	385
5288	TC	205*250*15	128	400
5289	TC	205*250*16	128	400
5290	TC	205*255*18	170	440
5291	TC	210*240*15	110	380
5292	TC	210*240*16	110	380
5293	TC	210*245*18	120	405
5294	TC	210*250*14	128	390
5295	TC	210*250*15	128	390
5296	TC	210*250*16	128	415
5297	TC	210*250*18	128	420
5298	TC	210*255*16	160	400
5299	TC	210*260*16	165	470
5300	TC	210*260*18	175	475
5301	TC	210*270*16	180	440
5302	TC	215*240*12	108	330
5303	TC	215*240*15	108	335
5304	TC	215*240*18	108	355
5305	TC	215*245*18	120	405
5306	TC	215*250*15	128	410
5307	TC	215*250*16	125	415
5308	TC	215*250*18	130	420
5309	TC	215*255*15	160	400
5310	TC	215*260*16	155	410
5311	TC	220*250*15	128	365

现货油封 OIL SEAL IN STOCK

序号	类型	规格	丁腈橡胶单价RMB	氟橡胶单价RMB
NO.	TYPE	SPECIFICATION	NBR PRICE	FKM PRICE
5312	TC	220*250*16	128	370
5313	TC	220*250*18	128	395
5314	TC	220*250*20	128	415
5315	TC	220*255*16	155	400
5316	TC	220*255*18	165	415
5317	TC	220*260*14	155	410
5318	TC	220*260*15	155	420
5319	TC	220*260*16	160	425
5320	TC	220*260*18	165	430
5321	TC	220*260*20	170	445
5322	TC	220*260*22	170	445
5323	TC	220*270*17	175	430
5324	TC	220*275*25	200	570
5325	TC	225*250*15	128	400
5326	TC	225*250*16	128	400
5327	TC	225*255*15	150	400
5328	TC	225*260*18	165	430
5329	TC	230*255*15	140	395
5330	TC	230*255*16	150	400
5331	TC	230*260*15	145	400
5332	TC	230*260*16	150	405
5333	TC	230*260*18	160	415
5334	TC	230*260*20	165	410
5335	TC	230*265*18	165	400
5336	TC	230*270*15	165	420
5337	TC	230*270*16	155	430
5338	TC	230*280*15	170	435
5339	TC	230*295*15	200	550
5340	TC	235*250*15	140	425
5341	TC	235*255*12	133	390
5342	TC	235*255*18	140	420
5343	TC	235*260*16	138	390
5344	TC	235*265*16	160	415
5345	TC	235*265*18	160	415
5346	TC	235*270*15	155	410
5347	TC	235*275*10	160	400
5348	TC	235*275*16	170	430
5349	TC	240*260*15	138	380
5350	TC	240*260*20	170	445
5351	TC	240*270*15	150	405
5352	TC	240*270*18	160	415
5353	TC	240*275*16	165	420
5354	TC	240*275*18	170	425
5355	TC	240*280*14	170	435
5356	TC	240*280*15	170	435
5357	TC	240*280*18	175	485
5358	TC	240*280*19	175	495
5359	TC	240*280*20	180	500
5360	TC	240*300*20	205	550
5361	TC	245*270*16	180	390
5362	TC	245*280*16	160	410
5363	TC	245*285*16	175	440
5364	TC	245*285*18	175	440
5365	TC	245*290*18	185	460
5366	TC	247.65*285.75*18	190	500
5367	TC	250*280*15	160	400
5368	TC	250*280*18	170	450
5369	TC	250*285*18	170	430
5370	TC	250*290*15	170	450
5371	TC	250*290*16	180	475
5372	TC	250*290*18	180	475
5373	TC	250*300*20	195	540
5374	TC	250*310*25	230	650
5375	TC	255*290*15	170	440
5376	TC	255*290*16	165	445
5377	TC	255*300*18	185	520
5378	TC	258*298*18	190	530
5379	TC	260*290*15	165	450
5380	TC	260*290*16	165	460
5381	TC	260*290*19	175	480
5382	TC	260*300*15	170	510
5383	TC	260*300*16	180	540

序号	类型	规格	丁腈橡胶单价RMB	氟橡胶单价RMB
NO.	TYPE	SPECIFICATION	NBR PRICE	FKM PRICE
5384	TC	260*300*18	185	545
5385	TC	260*300*20	190	585
5386	TC	260*320*18	215	600
5387	TC	260*320*20	220	610
5388	TC	260*320*25	240	690
5389	TC	263.6*284*10	160	512
5390	TC	265*290*16	160	400
5391	TC	265*300*14	170	450
5392	TC	265*310*10	180	600
5393	TC	270*290*10	170	459
5394	TC	270*300*15	200	460
5395	TC	270*310*15	200	470
5396	TC	270*310*16	185	480
5397	TC	270*310*18	195	525
5398	TC	270*310*20	200	555
5399	TC	270*320*16	200	530
5400	TC	270*320*18	205	570
5401	TC	270*320*20	215	590
5402	TC	270*330*28	280	640
5403	TC	275*310*15	180	450
5404	TC	275*310*16	180	455
5405	TC	275*320*15	200	570
5406	TC	280*310*15	180	450
5407	TC	280*310*16	180	460
5408	TC	280*310*26	220	630
5409	TC	280*315*15	190	460
5410	TC	280*316*18	195	530
5411	TC	280*320*15	190	550
5412	TC	280*320*16	200	560
5413	TC	280*320*18	200	570
5414	TC	280*320*20	205	580
5415	TC	280*325*16	230	550
5416	TC	280*340*28	280	650
5417	TC	285*320*20	210	580
5418	TC	290*320*15	210	550
5419	TC	290*330*18	230	580
5420	TC	290*330*20	230	580
5421	TC	290*630*20	1550	3200
5422	TC	298*338*16	248	580
5423	TC	300*330*18	230	550
5424	TC	300*332*16	240	540
5425	TC	300*335*18	248	580
5426	TC	300*340*15	240	580
5427	TC	300*340*16	240	590
5428	TC	300*340*18	240	600
5429	TC	300*340*20	240	610
5430	TC	300*360*20	280	800
5431	TC	300*360*25	280	850
5432	TC	300*380*20	380	950
5433	TC	300*380*30	460	1050
5434	TC	300*400*50	1000	2000
5435	TC	310*340*20	240	620
5436	TC	310*350*18	250	650
5437	TC	310*350*20	250	660
5438	TC	310*354*20	260	670
5439	TC	315*355*18	260	670
5440	TC	315*365*20	270	740
5441	TC	316*360*20	280	800
5442	TC	320*340*10	240	580
5443	TC	320*345*12	240	650
5444	TC	320*350*15	250	650
5445	TC	320*350*20	250	660
5446	TC	320*360*18	270	720
5447	TC	320*360*20	270	730
5448	TC	320*360*26	280	800
5449	TC	320*370*25	280	800
5450	TC	320*380*20	360	940
5451	TC	325*365*16	270	720
5452	TC	325*365*20	280	750
5453	TC	325*375*25	280	950
5454	TC	330*340*20	240	700
5455	TC	330*370*15	300	750

现货油封 OIL SEAL IN STOCK

序号	类型	规格	丁腈橡胶单价RMB	氟橡胶单价RMB
NO.	TYPE	SPECIFICATION	NBR PRICE	FKM PRICE
5456	TC	330*370*18	280	760
5457	TC	330*370*20	280	770
5458	TC	330*374*20	280	750
5459	TC	330*380*18	300	930
5460	TC	340*370*15	280	750
5461	TC	340*370*20	280	750
5462	TC	340*380*18	280	920
5463	TC	340*380*20	280	930
5464	TC	340*385*20	290	950
5465	TC	345*385*20	290	950
5466	TC	350*380*15	280	920
5467	TC	350*380*16	280	920
5468	TC	350*390*18	320	940
5469	TC	350*390*20	320	940
5470	TC	350*394*20	350	950
5471	TC	350*395*20	350	950
5472	TC	350*400*25	360	980
5473	TC	350*405*20	380	1100
5474	TC	350*580*20	1300	3500
5475	TC	360*390*15	320	930
5476	TC	360*390*16	320	930
5477	TC	360*400*18	360	950
5478	TC	360*400*20	360	960
5479	TC	360*400*25	360	980
5480	TC	360*404*20	360	1000
5481	TC	360*405*20	380	1100
5482	TC	367*406*18	380	1200
5483	TC	367*408*18	380	1200
5484	TC	368*406*18	380	1200
5485	TC	370*410*15	400	1100
5486	TC	370*410*18	400	1200
5487	TC	370*410*20	400	1200
5488	TC	370*414*17	400	1300
5489	TC	370*414*20	400	1300
5490	TC	370*414*20/24	400	1300
5491	TC	375*420*18	420	1200
5492	TC	380*420*16	420	1100
5493	TC	380*420*18	420	1100
5494	TC	380*420*20	420	1200
5495	TC	380*430*20	450	1200
5496	TC	380*440*25	480	1350
5497	TC	390*410*16	400	1200
5498	TC	390*430*16	450	1200
5499	TC	390*430*18	450	1200
5500	TC	390*430*20	450	1250
5501	TC	390*450*25	550	1500
5502	TC	393*417*15	600	1300
5503	TC	394*420*16	420	1200
5504	TC	400*430*15	450	1150
5505	TC	400*440*18	500	1250
5506	TC	400*440*20	480	1300
5507	TC	400*444*20	500	1300
5508	TC	400*450*20	550	1500
5509	TC	400*460*20	600	1500
5510	TC	406*444*18	500	1450
5511	TC	406.2*444.5*17	500	1500
5512	TC	410*440*15	500	1200
5513	TC	410*444*20	500	1450
5514	TC	410*450*20	550	1400
5515	TC	410*460*20	600	1500
5516	TC	410*470*20	700	1600
5517	TC	410*470*25	750	1800
5518	TC	420*460*16	600	1400
5519	TC	420*460*18	600	1400
5520	TC	420*460*20	600	1400
5521	TC	420*465*20	630	1450
5522	TC	420*470*20	700	1600
5523	TC	420*470*25	700	1600
5524	TC	420*480*28	800	2000
5525	TC	427*466*22	630	1500
5526	TC	430*470*18	700	1500
5527	TC	430*470*20	700	1500

序号	类型	规格	丁腈橡胶单价RMB	氟橡胶单价RMB
NO.	TYPE	SPECIFICATION	NBR PRICE	FKM PRICE
5528	TC	430*480*20	750	1700
5529	TC	430*480*22	750	1600
5530	TC	431*470*18	700	1600
5531	TC	435*485*17.5	750	2000
5532	TC	440*470*20	700	1500
5533	TC	440*480*18	750	1600
5534	TC	440*480*20	750	1600
5535	TC	440*490*20	800	1800
5536	TC	440*490*25	800	1900
5537	TC	450*480*12	750	1450
5538	TC	450*490*20	800	1800
5539	TC	450*490*22	800	1800
5540	TC	450*500*20	850	1900
5541	TC	450*500*25	850	1950
5542	TC	454*500*18	850	1900
5543	TC	454*504.8*21	900	2200
5544	TC	458*508*25	850	1950
5545	TC	460*500*20	850	1900
5546	TC	460*500*25	850	2000
5547	TC	460*510*20	900	2000
5548	TC	460*510*25	900	2100
5549	TC	460*520*20	950	2300
5550	TC	470*510*20	900	2000
5551	TC	470*520*20	950	2300
5552	TC	470*520*22	950	2300
5553	TC	470*520*25	950	2300
5554	TC	470*530*20	1000	2300
5555	TC	470*530*25	1000	2400
5556	TC	480*510*15	900	1900
5557	TC	480*520*20	950	2200
5558	TC	480*530*20	1000	2300
5559	TC	480*530*25	1000	2400
5560	TC	480*540*25	1050	2400
5561	TC	485*515*15	930	2100
5562	TC	485*520*16	950	2000
5563	TC	490*540*25	1050	2400
5564	TC	490*550*20	1100	2700
5565	TC	495*545*22	1100	2500
5566	TC	500*540*20	1050	2400
5567	TC	500*540*25	1050	2400
5568	TC	500*544*20	1100	2500
5569	TC	500*550*20	1100	2600
5570	TC	500*550*22	1100	2600
5571	TC	500*550*25	1100	2600
5572	TC	500*560*25	1150	2750
5573	TC	510*550*20	1100	2500
5574	TC	510*560*20	1150	2750
5575	TC	510*560*25	1150	2700
5576	TC	520*560*20	1150	2700
5577	TC	520*560*23	1150	2700
5578	TC	520*570*25	1200	2800
5579	TC	525*575*22	1260	2800
5580	TC	525*575*25	1260	2800
5581	TC	530*580*20	1300	2800
5582	TC	530*580*22	1300	2800
5583	TC	530*580*25	1300	2900
5584	TC	540*580*20	1300	2800
5585	TC	540*590*25	1350	2900
5586	TC	540*600*25	1400	3000
5587	TC	550*590*20	1350	2900
5588	TC	550*600*25	1400	2900
5589	TC	550*610*20	1450	3100
5590	TC	560*600*20	1400	2900
5591	TC	560*600*25	1400	2900
5592	TC	560*610*20	1450	3000
5593	TC	560*610*22	1450	3000
5594	TC	570*610*25	1450	3000
5595	TC	570*620*20	1500	3100
5596	TC	570*620*25	1500	3100
5597	TC	580*620*20	1500	3100
5598	TC	580*630*20	1550	3200
5599	TC	580*630*22	1550	3200

现货油封 OIL SEAL IN STOCK

序号	类型	规格	丁腈橡胶单价RMB	氟橡胶单价RMB
NO.	TYPE	SPECIFICATION	NBR PRICE	FKM PRICE
5600	TC	580*630*25	1550	3250
5601	TC	580*640*25	1600	3400
5602	TC	590*630*25	1550	3200
5603	TC	600*640*20	1600	3200
5604	TC	600*650*20	1650	3300
5605	TC	600*650*25	1650	3300
5606	TC	600*660*25	1700	3500
5607	TC	600*670*30	1800	4000
5608	TC	620*660*20	1700	3400
5609	TC	620*670*25	1800	3500
5610	TC	620*684*25	1850	3800
5611	TC	630*670*20	1800	3400
5612	TC	630*680*25	1850	3600
5613	TC	640*690*25	1900	4000
5614	TC	650*700*25	2000	4200
5615	TC	660*700*20	2000	4200
5616	TC	660*710*22	2000	4200
5617	TC	660*710*25	2000	4300
5618	TC	670*710*20	2000	4200
5619	TC	670*710*25	2000	4300
5620	TC	670*720*25	2050	4400
5621	TC	670*730*25	2100	4600
5622	TC	700*750*25	2200	4700
5623	TC	710*760*20	2300	4800
5624	TC	710*760*25	2300	4800
5625	TC	720*784*25	2550	5000
5626	TC	725*760*12	2300	4500
5627	TC	735*795*25	2650	5100
5628	TC	750*800*25	2700	5000
5629	TC	750*814*28	2800	5500
5630	TC	760*800*25	2700	5000
5631	TC	760*810*25	2750	5100
5632	TC	780*844*25	3000	5500
5633	TC	800*850*20	3000	5200
5634	TC	800*850*25	3000	5200
5635	TC	810*850*20	3000	5200
5636	TC	820*864*25	3100	5500
5637	TC	820*870*25	3200	5500
5638	TC	820*880*25	3300	5600
5639	TC	840*890*25	3400	5600
5640	TC	850*900*25	3500	6000
5641	TC	870*920*22	3700	6200
5642	TC	870*920*25	3700	6200
5643	TC	889*939.8*20	3900	6800
5644	TC	890*930*23	3800	6500
5645	TC	900*960*25	4200	6800
5646	TC	910*974*25	4200	7200
5647	TC	920*980*25	4300	7500
5648	TC	950*1000*25	4500	7800
5649	TC	975*1025*25	4800	7900
5650	TC	1000*1050*25	5000	8000

EC型 EC TYPE



序号	类型	规格	丁腈橡胶单价RMB
NO.	TYPE	SPECIFICATION	NBR PRICE
1	EC	8*4	4.5
2	EC	9*5	4.5
3	EC	10*4	4.5
4	EC	10*5	4.5
5	EC	12*5	4.5
6	EC	14*4	4.5
7	EC	15*4	4.5

序号	类型	规格	丁腈橡胶单价RMB
NO.	TYPE	SPECIFICATION	NBR PRICE
8	EC	16*4	4.5
9	EC	16*5	4.6
10	EC	18*4	4.5
11	EC	19*6	4.6
12	EC	20*5	4.6
13	EC	20*7	4.7
14	EC	21*5	4.9
15	EC	22*4	5
16	EC	22*5	5
17	EC	22*7	5
18	EC	24*5	5
19	EC	24*7	5.2
20	EC	25*7	5.3
21	EC	26*6	5.1
22	EC	26*6.5	5
23	EC	26*7	5
24	EC	27*5	4.9
25	EC	27.5*7	5.1
26	EC	28*5	5.1
27	EC	28*7	5.4
28	EC	30*5	5.6
29	EC	30*6	5.5
30	EC	30*7	5.1
31	EC	30*8	5.8
32	EC	32*5	5.5
33	EC	32*6	5.7
34	EC	32*7	5.4
35	EC	32*8	5.6
36	EC	35*5	5
37	EC	35*7	6.9
38	EC	35*8	6.5
39	EC	37*7	6.5
40	EC	37*10	6
41	EC	38*10	6.5
42	EC	40*7	6
43	EC	40*10	6.9
44	EC	42*7	6
45	EC	42*8	6.8
46	EC	42*9.5	7.5
47	EC	45*7	7.5
48	EC	47*6.5	7.1
49	EC	47*7	7.6
50	EC	47*8	7.6
51	EC	47*10	8.2
52	EC	47*13	8.8
53	EC	50*7	8.8
54	EC	52*7	7.3
55	EC	52*8	8.8
56	EC	52*9	8.5
57	EC	52*10	8.8
58	EC	55*7	9.3
59	EC	55*8	7.7
60	EC	55*10	9.3
61	EC	58*7	10.2
62	EC	59*8	10.5
63	EC	60*8	10.8
64	EC	62*7	10.5
65	EC	62*8	10.5
66	EC	62*10	11.3
67	EC	65*8	12
68	EC	65*10	12
69	EC	68*8	12
70	EC	70*8	12.4
71	EC	72*7	13.5
72	EC	72*9	15.4
73	EC	72*10	15
74	EC	72*12	15.6
75	EC	73*7	14.1
76	EC	75*7	14.3
77	EC	75*8	14.6
78	EC	75*10	15.1
79	EC	75*12	16.2

现货油封 OIL SEAL IN STOCK

序号	类型	规格	丁腈橡胶单价RMB
NO.	TYPE	SPECIFICATION	NBR PRICE
80	EC	78*10	15.5
81	EC	80*7	14.8
82	EC	80*8	15.2
83	EC	80*10	15.7
84	EC	80*12	18.6
85	EC	85*8	17.7
86	EC	85*10	17.9
87	EC	85*12	18
88	EC	90*7	16.7
89	EC	90*8	16.9
90	EC	90*10	18.4
91	EC	90*12	19.5
92	EC	95*10	22.6
93	EC	95*12	22.9
94	EC	95*15	23.2
95	EC	100*10	22.5
96	EC	100*12	24.2
97	EC	110*10	25.7
98	EC	110*12	27.2
99	EC	120*10	37.6
100	EC	120*12	39.2
101	EC	125*12	43.6
102	EC	130*10	43.7
103	EC	130*12	44.6
104	EC	130*15	49.3
105	EC	140*12	48
106	EC	140*15	55.2
107	EC	145*15	55.1
108	EC	150*10	53.7
109	EC	150*12	53
110	EC	150*15	57.9
111	EC	160*12	60.8
112	EC	160*15	64.5
113	EC	170*12	75.5
114	EC	170*15	80.4
115	EC	180*12	86
116	EC	180*15	92.3
117	EC	200*13	94.8
118	EC	215*15	124.5

VC型

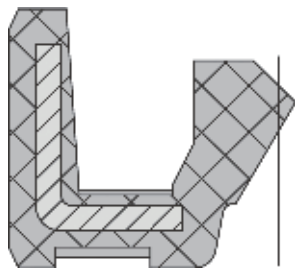

VC型：单唇，没有弹簧，钢骨架被橡胶全部包裹，旋转密封，用在压力底，无灰尘，无污染场合，一般用在孔直径和轴直径差较小的机器内部，最高压力0.03mpa(0.3kgf/cm2)

VC TYPE : SINGLE LIP, WITHOUT SPRING, STEEL FRAME WRAPPED IN RUBBER, ROTATING SEAL, USED IN HTE OCCASION OF LOW PRESSURE WITHOUT DUST AND POLLUTION. USUALLY INSTALLED IN MACHINES WITH LITTLE DIFFERENCE BETWEEN THE HOLE DIAMETER AND SHAFT DIAMETER, MAXIMUM PRESSURE 0.03 MPA (0.3 / Kg f / cm2)

序号	类型	规格	丁腈橡胶单价RMB	氟橡胶单价RMB
NO.	TYPE	SPECIFICATION	NBR PRICE	FKM PRICE
1	VC	3*9*3	5	13.5
2	VC	4*9*3	5	13.5
3	VC	4.8*9*2.7	5	12.5
4	VC	5*10*4	4.5	12
5	VC	5*11*4	5.5	12
6	VC	5*14*5	4.5	12

序号	类型	规格	丁腈橡胶单价RMB	氟橡胶单价RMB
NO.	TYPE	SPECIFICATION	NBR PRICE	FKM PRICE
7	VC	5*16*8	4.8	12.5
8	VC	5*20*3	4.9	14.5
9	VC	5.5*11*3	6.5	13.5
10	VC	5.5*16*8	4.5	12.5
11	VC	6*11*4	8.5	12.5
12	VC	6*12*4	4.5	12.5
13	VC	6*14*3	4.5	13.5
14	VC	6*14*4	4.5	13.5
15	VC	6*17.5*8	5	12.5
16	VC	6.5*10*2.8	5	15
17	VC	6.5*12*4	9.5	15
18	VC	7*13*4	4.5	12.5
19	VC	8*12*3	4.5	12.5
20	VC	8*13*5	4.5	12.5
21	VC	8*14*4	4.5	12.5
22	VC	8*15*4	4.5	12.5
23	VC	8*15*5	4.5	12.5
24	VC	8*17*4	4.6	12.5
25	VC	8*18*3.5	4.8	12.5
26	VC	8*18*5	4.5	12.5
27	VC	9*17*6	4.8	12.5
28	VC	9*17.5*7.6	5	13.5
29	VC	10*14*3	4.5	12.5
30	VC	10*16*4	4.5	12.5
31	VC	10*17*3	5	12.5
32	VC	10*17*4	4.5	12.5
33	VC	10*17*5	4.5	12.5
34	VC	10*18*6	4.5	12.5
35	VC	10*24*4	5	14.5
36	VC	10*24*7	5.2	14.5
37	VC	10.5*15*3/2.76	5	13.5
38	VC	11*16*3.2	4.5	12.5
39	VC	12*16*3	4.5	12.5
40	VC	12*17*2.5	4.5	12.5
41	VC	12*18*3	4.5	12.5
42	VC	12*18*5	4.5	12.5
43	VC	14*20*4	4.7	12.5
44	VC	14*24*6	4.9	14.5
45	VC	14*30*5	5.2	18
46	VC	14.8*30*5	5.5	18
47	VC	16*22*4	4.5	14
48	VC	16*22.75*4	5	14
49	VC	16*25*3	5.1	15
50	VC	17*25*3	5	15
51	VC	17*25*5	5.1	15
52	VC	17*26*2	5	18.2
53	VC	18*30*5	5.2	18
54	VC	18.9*30*5	5	18
55	VC	20*28*3	5	16
56	VC	20*28*4	5	16
57	VC	23.5*30*4	7	23
58	VC	25*31*7	5.5	18
59	VC	26*40*3	7.5	23
60	VC	28*35*5	7	19.5
61	VC	30*36*5	7	20
62	VC	30*38*5	7.5	21
63	VC	31*42*8	8	24
64	VC	31.75*42.88*4.78	9	28
65	VC	32*40*5	8	23
66	VC	34*39*3	7.5	25
67	VC	35*42*4	8	27
68	VC	35*47*5	9	29
69	VC	38*44*10	8	28
70	VC	40*62*5	11.5	42
71	VC	45*50*8	11	32
72	VC	45*52*4	9.5	33.5
73	VC	45*62*8	11.5	48
74	VC	60*90*10	18	70
75	VC	72*102*15	30	100
76	VC	82*130*15	50	210
77	VC	92*100*10	28	84
78	VC	270*290*10	170	459

现货油封 OIL SEAL IN STOCK

KC型

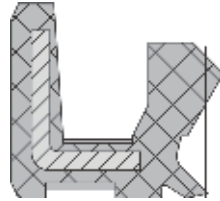

KC型：双唇，没有弹簧，钢骨架被橡胶全部包裹，旋转密封，用在压力底，一方有密封介质，另一方有轻微灰尘场合，一般用在孔直径和轴直径差较小的机器上，最高压力0.03mpa(0.3/kgf/cm2)

KC TYPE : DOUBLE LIPS, WITHOUT SPRING, STEEL FRAME WRAPPED IN RUBBER, ROTATING SEAL, USED IN THE OCCASION OF LOW PRESSURE WITH ONE SEALED MEDIA AND ANOTHER LITTLE DUST. USUALLY INSTALLED IN MACHINES WITH LITTLE DIFFERENCE BETWEEN THE HOLE DIAMETER AND SHAFT DIAMETER, MAXIMUM PRESSURE 0.03 MPA (0.3 / Kgf/cm2)

序号	类型	规格	丁腈橡胶单价RMB	氟橡胶单价RMB
NO.	TYPE	SPECIFICATION	NBR PRICE	FKM PRICE
1	KC	3.5*16.5*7	5.2	13.5
2	KC	4*12*5	4.5	12
3	KC	5*22*7	6	14.5
4	KC	6*12*4	4.5	12.5
5	KC	6*12*5	4.7	12.5
6	KC	6*12*8	4.5	13.5
7	KC	6*15*7	4.7	13.5
8	KC	6*16*7	4.8	12.5
9	KC	6*19*7	4.9	12.5
10	KC	6.2*15*7	4.9	12.5
11	KC	6.5*14.5*7	4.5	15
12	KC	7*14*3.5	4.5	12.5
13	KC	7*15*2.5	4.8	12.5
14	KC	7*15*5	4.5	12.5
15	KC	8*13*5	4.5	12.5
16	KC	8*14*3	4.5	12.5
17	KC	8*14*6	4.5	12.5
18	KC	8*15*4	4.5	12.5
19	KC	8*16*5	4.5	12.5
20	KC	9*15*5	4.7	13.5
21	KC	9*16*5	4.7	13.5
22	KC	9*16*7	4.7	13.5
23	KC	9.5*16*4	4.7	12.5
24	KC	10*15*4	4.5	13.5
25	KC	10*15*7	4.5	13.5
26	KC	10*16*3	4.8	12.5
27	KC	10*16*4	4.5	12.5
28	KC	10*17*3	5	12.5
29	KC	10*17*5	4.5	12.5
30	KC	10*18*5	4.5	12.5
31	KC	11*17*4	4.6	12.5
32	KC	11*18*4	4.5	12.5
33	KC	11*19*7	4.8	12.5
34	KC	12*18*4	4.5	12.5
35	KC	12*18*5	4.5	12.5
36	KC	12*18*6	4.5	12.5
37	KC	12*19*3	4.7	12.5
38	KC	12*19*4	4.8	12.5
39	KC	12*22*4	4.6	14
40	KC	12.5*19*4	4.8	13.5
41	KC	13*19*3.5	5.2	13.5
42	KC	13*19*7	4.9	13.5
43	KC	14*20*3	4.7	12.5
44	KC	14*20*4	4.7	12.5
45	KC	14*20*5	4.7	12.5
46	KC	14*20*7	4.8	12.5
47	KC	14*21*7	4.9	13.5
48	KC	14*24*6	4.9	14.5
49	KC	15*21*3	4.8	13
50	KC	15*21*4	4.8	13
51	KC	15*21*7	4.9	14

序号	类型	规格	丁腈橡胶单价RMB	氟橡胶单价RMB
NO.	TYPE	SPECIFICATION	NBR PRICE	FKM PRICE
52	KC	15*22*3	4.6	14
53	KC	15*22*7	5	14.5
54	KC	15*23*3	5.1	14.5
55	KC	15*25*5	4.6	15
56	KC	15*28*4	5.1	16
57	KC	15*28*5	5	16
58	KC	16*21*6	4.9	13
59	KC	16*22*4	4.5	14
60	KC	16*22*6	4.7	14
61	KC	16*22*7	4.9	14.5
62	KC	16*23*3.3	4.9	14.5
63	KC	16*23*3.5	4.9	14.5
64	KC	16*23*5	5	14.5
65	KC	16*24*3	4.6	14.5
66	KC	16*25*5	5.1	15
67	KC	16*26*3	6	15.5
68	KC	16.5*25*5	5.1	17
69	KC	17*22*3	4.9	17
70	KC	17*23*4	5	17
71	KC	17*23*10	6	17
72	KC	17*24*2.5	4.6	17
73	KC	17*24*3	4.6	17
74	KC	17*24*5	4.6	14.5
75	KC	17*25*4	5	15
76	KC	17.5*26*3	6	19.5
77	KC	18*24*4	4.5	14.5
78	KC	18*24*5	4.5	14.5
79	KC	18*24*7	5.1	14.5
80	KC	18*26*4	5	15.5
81	KC	18*26*7	5.2	16
82	KC	18.5*26*2.7	6	19.5
83	KC	19*25*6	5	15
84	KC	19*25*7	5.5	15
85	KC	19*26*3	6	16
86	KC	20*25*4	5	18.5
87	KC	20*25*7	5	18.5
88	KC	20*25.5*7	5	18.5
89	KC	20*26*3	5	18.5
90	KC	20*26*3.5	6	18.5
91	KC	20*26*4	5	15.5
92	KC	20*26*4.5	5	15.5
93	KC	20*26*5	5	15.5
94	KC	20*27*4	5	15.5
95	KC	21*26*4	6	15.5
96	KC	21*27*5	5	16
97	KC	22*28*4	5	16
98	KC	22*28*7	5.2	16
99	KC	22*28*8	6	16
100	KC	22*29*4	6	18
101	KC	22*29*5	6	18
102	KC	22*30*4	5.2	18
103	KC	22*35*5.4	7.0	20
104	KC	24*31*5	6	18
105	KC	25*30*7	5.5	18
106	KC	25*32*4	6	18
107	KC	25*32*5	6	18
108	KC	26*32*4	6	18.5
109	KC	27*32*7	6.5	18.5
110	KC	28*35*4	7.0	20
111	KC	28*47*7	8	29
112	KC	28*47.2*7	8	29
113	KC	29*35*4.4	8	29
114	KC	30*36*5	7	20
115	KC	31*36*7	7	21
116	KC	32*38*5	7	23
117	KC	35*40*6	8	27
118	KC	35*41*8	8	27
119	KC	35*42*8	8	24
120	KC	36*43*8	7.5	25
121	KC	38*44*10	8	28
122	KC	40*58*3	11	54
123	KC	40*60*5	13	49.5
124	KC	45*52*8	9.5	33.5

现货油封 OIL SEAL IN STOCK

序号	类型	规格	丁腈橡胶单价RMB	氟橡胶单价RMB
NO.	TYPE	SPECIFICATION	NBR PRICE	FKM PRICE
125	KC	49*56*9	12	43
126	KC	50*56*7	12	43
127	KC	60*70*10	14	58
128	KC	60*70*12	15	58
129	KC	65*75*12	14.5	63
130	KC	65*77*4	15	67
131	KC	72*82*10	16	67
132	KC	75*85*10	17	68
133	KC	85*95*10	20	84
134	KC	95*105*10	28	88

SC型

SC型：单唇，一根弹簧，钢骨架被橡胶全部包裹，旋转密封，用在压力底，无灰尘、无污染的场所，最高压力0.03mpa(0.3kgf/cm2)

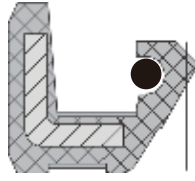

SC TYPE : SINGLE LIP, SINGLE SPRING , STEEL FRAME WRAPPED IN RUBBER, ROTATING SEAL, USED IN THE OCCASION OF LOW PRESSURE WITHOUT DUST AND POLLUTION. MAXIMUM PRESSURE 0.03 MPA (0.3 / Kg / cm2)

序号	类型	规格	丁腈橡胶单价RMB	氟橡胶单价RMB
NO.	TYPE	SPECIFICATION	NBR PRICE	FKM PRICE
1	SC	4*16*6	4.5	12.5
2	SC	5*12*5	4.5	12.5
3	SC	5*19*8	5	15.3
4	SC	6*25*6	5	17
5	SC	6.5*13.6*5	4.5	12.5
6	SC	6.5*13.6*6	4.5	12.5
7	SC	6.5*18.6*6	4.5	14.6
8	SC	7*16*7	4.5	14.6
9	SC	8*16*7	4.5	13.7
10	SC	9*22*7	4.7	17.3
11	SC	9.52*16.5*4	5	13.5
12	SC	9.52*19.05*5.55	5	15.3
13	SC	10*18*6	4.5	13.5
14	SC	10*24*7	5.2	18
15	SC	11*17*4	4.6	12.5
16	SC	11*17*5	4.5	12.5
17	SC	11*18*4	4.5	12.9
18	SC	12*18*4.5	4.5	12.9
19	SC	12*19*5	4.7	13.6
20	SC	12*20*5	4.5	14.4
21	SC	12*21*4	4.6	13.5
22	SC	12*24*4.5	5	15
23	SC	12*25*4.5	5	17
24	SC	12*26*7	5	18.1
25	SC	12*32*6	5.5	18.5
26	SC	12.45*22*6	5	15.3
27	SC	12.6*25.4*8	5	18.1
28	SC	12.7*22.22*6.35	5	15.3
29	SC	13*24*7	5	18
30	SC	13*25*5	4.8	15
31	SC	14*22*4	4.6	14.1
32	SC	14.72*22*7	4.8	14.1
33	SC	14.8*27*3.8	5	17
34	SC	14.8*27*7.5	5	17
35	SC	14.8*30*5	5.5	19.5
36	SC	15*21*4	4.8	13.5
37	SC	15*21*5	4.8	13.5
38	SC	15*24*4	4.6	15
39	SC	15*25*5	4.6	17
40	SC	15*30*7	5.1	20.4
41	SC	16*24*5	4.6	15
42	SC	16*28*7	5.5	20.3
43	SC	16*35*7	6	24.5
44	SC	17*25*4	5	17
45	SC	17*28*5.5	5.5	17.1
46	SC	17*28*6	5	18
47	SC	17*28.5*6	5	18

序号	类型	规格	丁腈橡胶单价RMB	氟橡胶单价RMB
NO.	TYPE	SPECIFICATION	NBR PRICE	FKM PRICE
48	SC	17*32*7	5.5	20.4
49	SC	17*40*7	7.5	25.3
50	SC	17.45*28.57*6.35	5.5	19.5
51	SC	18*30*6	5.4	19.9
52	SC	18*35*10	6	27.8
53	SC	19*31.70*6.4	5	19.9
54	SC	19.3*29.1*6.4	5.5	19.5
55	SC	19.5*35*10	7	29.5
56	SC	20*30*7	5	19.2
57	SC	20*32*7	5.5	18.5
58	SC	20*35*5.3	6.5	23.3
59	SC	20*35*5.5	6.5	23.3
60	SC	20*35*10	7	29.9
61	SC	20*40*10	7.5	32.3
62	SC	20*43*7.5	7.5	28.5
63	SC	20*52*7	9.5	39.8
64	SC	20*52*10	9.5	48.2
65	SC	21.5*32*5.4	6	18.5
66	SC	22*35*7	7	22.8
67	SC	22*40*10	7.5	32.3
68	SC	22*45*9	8	28.5
69	SC	23*37*7	7	25.2
70	SC	24*35*7	7	22.2
71	SC	24*40*7	7.5	26.4
72	SC	24.5*40*8.5	7.5	30.8
73	SC	24.5*42*7	7.5	29
74	SC	25*32*4	6	18.5
75	SC	25*35*7	7	21.9
76	SC	25*36*7	7	24.2
77	SC	25*38*7	7	24.9
78	SC	25*40*3	7.5	28.5
79	SC	25*40*7	7.5	28
80	SC	25*42*10	7.5	35.8
81	SC	25*46*7	8.5	33.5
82	SC	25*47*7	8	33.6
83	SC	25*47*10	8	39.1
84	SC	25*52*6	9.5	36.1
85	SC	25*62*8	12	62.7
86	SC	26*47*10	8.5	38.5
87	SC	26*48*10	9	46.3
88	SC	27*35*7	7	21
89	SC	27*37*3	7	25.2
90	SC	27*49*7.5	10	33.5
91	SC	27*57.2*9.5	11	59.2
92	SC	27.75*37.3*6.5	7	24.9
93	SC	28*38*5.5	7.5	23.5
94	SC	28*38*6	7	23.5
95	SC	28*38*7	7	23.5
96	SC	28.5*35*3	7	22.8
97	SC	28.57*38.1*6.35	7	25.3
98	SC	28.58*57.15*9.52	11	59.2
99	SC	29*39.6*9.5	7.5	32.3
100	SC	29*41*9	8	30.8
101	SC	30*37*4	7	22
102	SC	30*40*7	7.5	25
103	SC	30*42*6	7.5	25
104	SC	30*42*7	7.5	25.4
105	SC	30*47*10	8	38.5
106	SC	30*50*10	9	42.7
107	SC	30*52*8	9.5	38.4
108	SC	30*55*7	10	54
109	SC	30*55*10	10.1	57.2
110	SC	30*72*6	13.5	80.8
111	SC	31*50*8	9	39.8
112	SC	31*52*7	9	37.4
113	SC	31.7*44.5*8	8	28.5
114	SC	31.70*44.50*8	8	28.5
115	SC	31.75*50.8*9.52	9	42.7
116	SC	32*42*7	7.5	25
117	SC	32*44.4*6.3	9	33.5
118	SC	32*45*7	7.5	30.2
119	SC	32*47*7	8	31.2

现货油封 OIL SEAL IN STOCK

序号	类型	规格	丁腈橡胶单价RMB	氟橡胶单价RMB
NO.	TYPE	SPECIFICATION	NBR PRICE	FKM PRICE
120	SC	32*50.8*9.5	9	42.7
121	SC	32*52*7	9	37.4
122	SC	32*52*10	9.5	44.3
123	SC	33*43*7	7.5	29.5
124	SC	33*50*7	9.5	36.6
125	SC	33*54*12.5	9.5	48.9
126	SC	34*49*7	9.5	33.6
127	SC	34*50*7	9.5	36.6
128	SC	34*52*6	9.5	39.4
129	SC	35*47*7	8	30
130	SC	35*52*8	9	41.5
131	SC	35*58*10	11	59.2
132	SC	35*58*12	12.2	66.5
133	SC	36*48*7	10	33.5
134	SC	36*50*10	9	41.2
135	SC	36*52*7	9.5	37
136	SC	37*62*14	13	71.3
137	SC	37*66*9.5	13	65.8
138	SC	38*52*10	9.5	43.4
139	SC	38*58*10	10.5	60.4
140	SC	38*62*12	13	69.9
141	SC	38*68*10	14	76.5
142	SC	38.1*50.8*6.35	10	43.3
143	SC	40*52*7	9	35.2
144	SC	40*55*6	10	48.1
145	SC	40*55*7	10	48.9
146	SC	40*63*10	12.5	71.3
147	SC	40*72*6	13.5	73.2
148	SC	40*72*10	14.5	86.5
149	SC	42*55*9	11	52.7
150	SC	42*56*7	10	49.3
151	SC	42*58*7	11	50
152	SC	42*58*10	11	57.5
153	SC	42*64*8	13	60.7
154	SC	42*65*10	12.8	65.5
155	SC	43*57*9.5	11	52.7
156	SC	44*62*10	12	62.9
157	SC	44.5*90*13	19.5	95.6
158	SC	45*55*8	10	48.1
159	SC	45*60*7	11.5	50.4
160	SC	45*62*10	11.5	58.4
161	SC	45*65*8	12	64.2
162	SC	45*65*10	12	67.6
163	SC	47*56*7	10.5	40
164	SC	47.63*69.85*9.5	14	69.9
165	SC	48*62*9	12	58
166	SC	48*65*10	13	61.2
167	SC	48*70*10	13.5	69.9
168	SC	48*72.5*10	14	80.8
169	SC	50*70*10	13	73.2
170	SC	50.8*69.85*12.7	14	74.7
171	SC	55*70*10	13.5	67.6
172	SC	55*72*8	13.5	67.1
173	SC	55*72*10	13.5	68.9
174	SC	55*80*10	15	84.4
175	SC	55*85*10	17	77.3
176	SC	55*85*13	20	109.5
177	SC	58*86*13	16	95.6
178	SC	59*86*13	16	95.6
179	SC	60*75*8	14	68.5
180	SC	60*80*8	15	74.7
181	SC	60*80*10	15	86.6
182	SC	60*85*10	16.3	86.8
183	SC	60*90*10	18	90.9
184	SC	60*90*12	18	99.3
185	SC	62*85*10	16	82.2
186	SC	62*90*12	19.5	99.5
187	SC	63*83*9.5	17	83.5
188	SC	63*89*12.7	16	95.6
189	SC	64*95*10	22	100.4
190	SC	65*80*8	15	73.4
191	SC	65*85*10	16	83.8

序号	类型	规格	丁腈橡胶单价RMB	氟橡胶单价RMB
NO.	TYPE	SPECIFICATION	NBR PRICE	FKM PRICE
192	SC	68*80*8	15	66
193	SC	70*95*10	20	98.8
194	SC	70*101.5*16/17	30	124.8
195	SC	73*90*10	18.5	86.8
196	SC	74*102*10	30	110.6
197	SC	75*100*10	22	99.1
198	SC	78*90*10	18	99.3
199	SC	79*110*10	30	124.8
200	SC	80*100*10	21	98.6
201	SC	80*105*12	23	122
202	SC	80*110*12	26.5	139
203	SC	80*125*13	45	177.5
204	SC	85*110*12	26.5	132
205	SC	85*126*12	43	171.1
206	SC	90*120*12	38	163.4
207	SC	95*125*12	38.3	171.1
208	SC	100*125*12	36.7	156.7
209	SC	105*138*12	45.5	195.4
210	SC	110*135*12	40	159.2
211	SC	114*145*15	55	209.7
212	SC	115*140*10	43	177.5
213	SC	115*145*12	50	192.8
214	SC	120*140*13	43	186.7
215	SC	120*150*12	47	196.8
216	SC	123*146*10.5	47	186.7
217	SC	130*150*10	50	165.2
218	SC	130*160*15	53	246.5
219	SC	135*165*15	60	240.3
220	SC	135*200*15	105	384.8
221	SC	140*170*15	63	309.6
222	SC	144*175*15	70	265.2
223	SC	150*180*8	75	225.8
224	SC	150*180*13	80	267
225	SC	150*180*15	75	283.5
226	SC	155*180*12	80	239.8
227	SC	160*190*15	86	384.8
228	SC	175*200*12	82	359.2
229	SC	180*210*15	90	411
230	SC	180*220*15	105	457
231	SC	185*220*15	105	437.5
232	SC	200*230*15	100	479.5
233	SC	200*240*15	112	573.7
234	SC	210*250*15	128	521.8
235	SC	220*260*15	155	575.9
236	SC	226*260*15	150	555.6
237	SC	230*260*15	145	548.2
238	SC	240*280*15	170	595.3
239	SC	250*290*15	170	614.3
240	SC	250*290*16	170	614.5
241	SC	254*285.75*15.88	170	595.3
242	SC	255*290*15	170	614.5
243	SC	260*280*10	170	595.3
244	SC	260*300*15	170	617.8
245	SC	260*300*18	185	697.1
246	SC	263.6*284.34*10	170	595.3
247	SC	264.6*284.34*10	170	595.3
248	SC	270*290*10	170	459
249	SC	300*340*18	240	826.7
250	SC	300*340*20	240	820.7
251	SC	310*370*25	275	917
252	SC	320*340*10	240	715.9
253	SC	320*360*15	265	882.8
254	SC	320*360*18	270	895.8
255	SC	340*380*18	280	917
256	SC	370*414*17	390	1300
257	SC	370*414*20	400	1334
258	SC	394*420*16	420	1167
259	SC	420*470*22	700	1584
260	SC	490*532*20	1050	3000
261	SC	750*800*25	2700	5834

现货油封 OIL SEAL IN STOCK

VA型 SEAL

VA型油封的功能是防止灰尘、水或其他腐蚀性介质进入轴承箱，同时保留油脂。
材质NBR。

The function of a VA-seal is to exclude dirt, water or other aggressive media from entering bearing housings while also retaining grease.

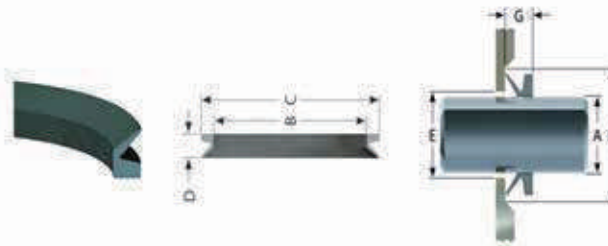

Part Number	Seal Dimensions				Housing Dimensions		
	A	B	C	D	E	F	G
	Shaft Diameter	I.D.	O.D.	Height	I.D.	O.D.	Width
VA 003	2.70 – 3.50	2.5	5.5	3	A + 1.00	A + 4.00	2.50 ±
VA 004	3.50 – 4.50	3.2	7.2	3.7	A + 1.00	A + 6.00	3.00 ±
VA 005	4.50 – 5.50	4	8	3.7	A + 1.00	A + 6.00	3.00 ±
VA 006	5.50 – 6.50	5	9	3.7	A + 1.00	A + 6.00	3.00 ±
VA 007	6.50 – 8.00	6	10	3.7	A + 1.00	A + 6.00	3.00 ±
VA 008	8.00 – 9.50	7	11	3.7	A + 1.00	A + 6.00	3.00 ±
VA 010	9.50 – 11.50	9	15	5.5	A + 2.00	A + 9.00	4.50 ±
VA 012	11.50 – 12.50	10.5	16.5	5.5	A + 2.00	A + 9.00	4.50 ±
VA 013	12.50 – 13.50	11.7	17.5	5.5	A + 2.00	A + 9.00	4.50 ±
VA 014	13.50 – 15.50	12.5	18.5	5.5	A + 2.00	A + 9.00	4.50 ±
VA 016	15.50 – 17.50	14	20	5.5	A + 2.00	A + 9.00	4.50 ±
VA 018	17.50 – 19.00	16	22	5.5	A + 2.00	A + 9.00	4.50 ±
VA 020	19.00 – 21.00	18	26	7.5	A + 2.00	A + 12.00	6.00 ±
VA 022	21.00 – 24.00	20	28	7.5	A + 2.00	A + 12.00	6.00 ±
VA 025	24.00 – 27.00	22	30	7.5	A + 2.00	A + 12.00	6.00 ±
VA 028	27.00 – 29.00	25	33	7.5	A + 3.00	A + 12.00	6.00 ±
VA 030	29.00 – 31.00	27	35	7.5	A + 3.00	A + 12.00	6.00 ±
VA 032	31.00 – 33.00	29	37	7.5	A + 3.00	A + 12.00	6.00 ±
VA 035	33.00 – 36.00	31	39	7.5	A + 3.00	A + 12.00	6.00 ±
VA 038	36.00 – 38.00	34	42	7.5	A + 3.00	A + 12.00	6.00 ±
VA 040	38.00 – 43.00	36	46	9	A + 3.00	A + 15.00	7.00 ±
VA 045	43.00 – 48.00	40	50	9	A + 3.00	A + 15.00	7.00 ±
VA 050	48.00 – 53.00	45	55	9	A + 3.00	A + 15.00	7.00 ±
VA 055	53.00 – 58.00	49	59	9	A + 3.00	A + 15.00	7.00 ±
VA 060	58.00 – 63.00	54	64	9	A + 3.00	A + 15.00	7.00 ±
VA 065	63.00 – 68.00	58	68	9	A + 3.00	A + 15.00	7.00 ±
VA 070	68.00 – 73.00	63	75	11	A + 4.00	A + 18.00	9.00 ±
VA 075	73.00 – 78.00	67	79	11	A + 4.00	A + 18.00	9.00 ±
VA 080	78.00 – 83.00	72	84	11	A + 4.00	A + 18.00	9.00 ±
VA 085	83.00 – 88.00	76	88	11	A + 4.00	A + 18.00	9.00 ±
VA 090	88.00 – 93.00	81	93	11	A + 4.00	A + 18.00	9.00 ±
VA 095	93.00 – 98.00	85	97	11	A + 4.00	A + 18.00	9.00 ±
VA 100	98.00 – 105.00	90	102	11	A + 4.00	A + 18.00	9.00 ±
VA 110	105.00 – 115.00	99	113	12.8	A + 4.00	A + 21.00	10.50 ±
VA 120	115.00 – 125.00	108	122	12.8	A + 4.00	A + 21.00	10.50 ±
VA 130	125.00 – 135.00	117	131	12.8	A + 4.00	A + 21.00	10.50 ±
VA 140	135.00 – 145.00	126	140	12.8	A + 4.00	A + 21.00	10.50 ±
VA 150	145.00 – 155.00	135	149	12.8	A + 4.00	A + 21.00	10.50 ±
VA 160	155.00 – 165.00	144	160	14.5	A + 5.00	A + 24.00	12.00 ±
VA 170	165.00 – 175.00	153	169	14.5	A + 5.00	A + 24.00	12.00 ±
VA 180	175.00 – 185.00	162	178	14.5	A + 5.00	A + 24.00	12.00 ±

现货油封 OIL SEAL IN STOCK

Part Number	Seal Dimensions				Housing Dimensions		
	A	B	C	D	E	F	G
	Shaft Diameter	I.D.	O.D.	Height	I.D.	O.D.	Width
VA 190	185.00 – 195.00	171	187	14.5	A + 5.00	A + 24.00	12.00 ±
VA 199	195.00 – 210.00	180	196	14.5	A + 5.00	A + 24.00	12.00 ±
VA 200	190.00 – 210.00	180	210	25	A + 10.00	A + 45.00	20.00 ±
VA 220	210.00 – 235.00	198	228	25	A + 10.00	A + 45.00	20.00 ±
VA 250	235.00 – 265.00	225	255	25	A + 10.00	A + 45.00	20.00 ±
VA 275	265.00 – 290.00	247	277	25	A + 10.00	A + 45.00	20.00 ±
VA 300	290.00 – 310.00	270	300	25	A + 10.00	A + 45.00	20.00 ±
VA 325	310.00 – 335.00	292	322	25	A + 10.00	A + 45.00	20.00 ±
VA 350	335.00 – 365.00	315	345	25	A + 10.00	A + 45.00	20.00 ±
VA 375	365.00 – 390.00	337	367	25	A + 10.00	A + 45.00	20.00 ±
VA 400	390.00 – 430.00	360	390	25	A + 10.00	A + 45.00	20.00 ±
VA 450	430.00 – 480.00	405	435	25	A + 10.00	A + 45.00	20.00 ±
VA 500	480.00 – 530.00	450	480	25	A + 10.00	A + 45.00	20.00 ±
VA 550	530.00 – 580.00	495	525	25	A + 10.00	A + 45.00	20.00 ±
VA 600	580.00 – 630.00	540	570	25	A + 10.00	A + 45.00	20.00 ±
VA 650	630.00 – 665.00	600	630	25	A + 10.00	A + 45.00	20.00 ±
VA 700	665.00 – 705.00	630	660	25	A + 10.00	A + 45.00	20.00 ±
VA 725	705.00 – 745.00	670	700	25	A + 10.00	A + 45.00	20.00 ±
VA 750	745.00 – 785.00	705	735	25	A + 10.00	A + 45.00	20.00 ±
VA 800	785.00 – 830.00	745	775	25	A + 10.00	A + 45.00	20.00 ±
VA 850	830.00 – 875.00	785	815	25	A + 10.00	A + 45.00	20.00 ±
VA 900	875.00 – 920.00	825	855	25	A + 10.00	A + 45.00	20.00 ±
VA 950	920.00 – 965.00	865	895	25	A + 10.00	A + 45.00	20.00 ±
VA 1000	965.00 – 1015.00	910	940	25	A + 10.00	A + 45.00	20.00 ±
VA 1100	1065.00 – 1115.00	1000	1030	25	A + 10.00	A + 45.00	20.00 ±
VA 1150	1115.00 – 1165.00	1045	1075	25	A + 10.00	A + 45.00	20.00 ±
VA 1200	1165.00 – 1215.00	1090	1120	25	A + 10.00	A + 45.00	20.00 ±
VA 1250	1215.00 – 1270.00	1135	1165	25	A + 10.00	A + 45.00	20.00 ±
VA 1300	1270.00 – 1320.00	1180	1210	25	A + 10.00	A + 45.00	20.00 ±
VA 1350	1320.00 – 1370.00	1225	1255	25	A + 10.00	A + 45.00	20.00 ±
VA 1400	1370.00 – 1420.00	1270	1300	25	A + 10.00	A + 45.00	20.00 ±
VA 1450	1420.00 – 1470.00	1315	1345	25	A + 10.00	A + 45.00	20.00 ±
VA 1500	1470.00 – 1520.00	1360	1390	25	A + 10.00	A + 45.00	20.00 ±
VA 1550	1520.00 – 1570.00	1405	1435	25	A + 10.00	A + 45.00	20.00 ±
VA 1600	1570.00 – 1620.00	1450	1480	25	A + 10.00	A + 45.00	20.00 ±
VA 1650	1620.00 – 1670.00	1495	1525	25	A + 10.00	A + 45.00	20.00 ±
VA 1700	1670.00 – 1720.00	1540	1570	25	A + 10.00	A + 45.00	20.00 ±
VA 1750	1720.00 – 1770.00	1585	1615	25	A + 10.00	A + 45.00	20.00 ±
VA 1800	1770.00 – 1820.00	1630	1660	25	A + 10.00	A + 45.00	20.00 ±
VA 1850	1820.00 – 1870.00	1675	1705	25	A + 10.00	A + 45.00	20.00 ±
VA 1900	1870.00 – 1920.00	1720	1750	25	A + 10.00	A + 45.00	20.00 ±
VA 1950	1920.00 – 1970.00	1765	1795	25	A + 10.00	A + 45.00	20.00 ±
VA 2000	1970.00 – 2020.00	1810	1840	25	A + 10.00	A + 45.00	20.00 ±

有模具可订做油封 HAVE MOLD

R35型 R37型

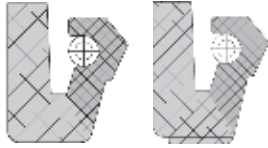

R35 R37型夹布油封型-主要用于轧钢机及重型机械传动，结构是用夹布增强外缘肩部；它与橡胶密封唇紧密结合，并用弹簧给密封唇部以预载，密封效果好

R35 R37 type -seal with Canvas :mainly used in rolling mill and heavy machinery transmission, with structure of canvas to strengthen the outer neck part, bonding tightly with the rubber sealing lip, spring will be serve as preload of the sealing lip, to fulfill excellent sealing performance.

序号	规格	丁腈橡胶单价
NO.	SPECIFICATION	NBR PRICE
9617	100*125*12.5	18.75
9618	100*132*12.5	19.80
9619	105*145*16	21.75
9620	130*160*12	24.00
9621	140*180*16	27.00
9622	150*190*16	28.50
9623	160*200*12	30.00
9624	160*190*15	28.50
9625	170*190*15	28.50
9626	170*200*12	30.00
9627	180*210*14.5	31.50
9628	180*210*16	31.50
9629	180*215*18	32.25
9630	180*220*16	33.00
9631	195*235*16	35.25
9632	190*230*16	34.50
9633	200*230*14	34.50
9634	210*245*18	36.75
9635	210*250*16/20	37.50
9636	220*255*18	38.25
9637	210*260*16	39.00
9638	210*267*18	40.05
9639	225*265*16	39.75
9640	230*270*16	40.50
9641	235*275*16	41.25
9642	240*280*16	42.00
9643	240*275*18	41.25
9644	250*290*18	43.50
9645	254*292.1*16	43.82
9646	255*299*20	44.85
9647	260*290*16	43.50
9648	260*300*14	45.00
9649	260*300*20	45.00
9650	260*304*20	45.60
9651	267*311*19	46.65
9652	270*310*18	46.50
9653	270*314*20	47.10
9654	275*319*20	47.85
9655	280*310*18	46.50
9656	280*320*20	48.00
9657	280*324*20	48.60

序号	规格	丁腈橡胶单价
NO.	SPECIFICATION	NBR PRICE
9658	290*330*18	49.50
9659	290*334*20	50.10
9660	300*330*15	49.50
9661	300*344*20	51.60
9662	310*334*24	50.10
9663	310*350*20	52.50
9664	310*344*20	51.60
9665	320*360*18	54.00
9666	320*360*20.3	54.00
9667	320*364*20	54.60
9668	315*365*22	54.75
9669	330*370*20	55.50
9670	330*374*20	56.10
9671	340*380*18	57.00
9672	340*384*20	57.60
9673	350*380*20	57.00
9674	350*390*20	58.50
9675	360*400*20	72.00
9676	360*404*20	72.72
9677	365*405*18	72.90
9678	370*410*20	73.80
9679	370*414*20	74.52
9680	380*420*20	75.60
9681	385*425*20	76.50
9682	390*430*20	77.40
9683	400*440*20	79.20
9684	400*444*20	79.92
9685	410*460*20	82.80
9686	425*465*20	83.70
9687	420*470*22	84.60
9688	430*480*22	86.40
9689	440*480*22	86.40
9690	440*474*20	85.32
9691	440*485*20	87.30
9692	440*490*22	88.20
9693	440*490*28	88.20
9694	455*505*22	90.90
9695	454*500*18	90.00
9696	460*510*25	91.80
9697	470*520*22	93.60
9698	480*530*22	95.40
9699	485*535*22	96.30
9700	490*540*22	97.20
9701	495*545*22	98.10
9702	500*550*22	99.00
9703	510*550*20	99.00
9704	510*554*20	99.72
9705	515*565*22	101.70
9706	525*575*22	103.50
9707	530*580*22	104.40
9708	540*590*22	106.20
9709	545*590*22	106.20
9710	545*595*22	107.10
9711	550*600*22	108.00
9712	560*604*20	108.72
9713	560*610*22	109.80
9714	560*610*25	109.80
9715	570*620*22	111.60
9716	585*630*22	113.40
9717	590*640*25	115.20

序号	规格	丁腈橡胶单价
NO.	SPECIFICATION	NBR PRICE
9718	600*650*22	117.00
9719	620*680*25	122.40
9720	620*684*25	123.12
9721	630*694*25	124.92
9722	630*680*22	122.40
9723	636*692*30.5	124.56
9724	640*684*20	123.12
9725	664*714*25	128.52
9726	670*734*25	132.12
9727	680*730*25	131.40
9728	685*737*22	132.66
9729	690*754*25	135.72
9730	700*760*25	136.80
9731	710*760*22	136.80
9732	710*774*25	139.32
9733	720*784*25	141.12
9734	730*770*25	138.60
9735	720*780*25	140.40
9736	730*780*22	140.40
9737	735*800*25	180.00
9738	750*800*20	180.00
9739	760*804*20	180.90
9740	750*814*25	183.15
9741	770*834*25	187.65
9742	780*844*25	189.90
9743	800*864*25	194.40
9744	805*869*25	195.53
9745	810*874*25	196.65
9746	820*870*25	195.75
9747	830*894*25	201.15
9748	860*924*25	207.90
9749	870*934*25	210.15
9750	880*940*30	211.50
9751	890*940*25	211.50
9752	890*954*25	214.65
9753	970*1030*21.5	231.75

V型



V型组合夹布油封-适用于冶金、矿山、通用设备、超高压油缸活塞与活塞杆往复运动最理想的自由组合密封件。工作压力40MPa;耐介质 矿物油型液压油和难燃液液压油。

V type -seal with Canvas—used in Metallurgy, mining, general equipment, is the ideal free combination seal in ultra-high pressure cylinder piston and piston rod reciprocating movement. Working pressure 40MPa; resistant medium :mineral hydraulic oil and flame retardant hydraulic oil.

序号	规格	丁腈橡胶单价
NO.	SPECIFICATION	NBR PRICE
9754	12*24	1.08
9755	18*33	1.08
9756	20*30	1.08
9757	20*32	1.08
9758	20*35	1.2
9759	22*38	1.2
9760	24*38	1.2
9761	25*37	1.2

OIL SEAL FACTORY

有模具可订做油封 HAVE MOLD

序号	规格	丁腈橡胶单价
NO.	SPECIFICATION	NBR PRICE
9762	25*40	1.2
9763	25*45	1.56
9764	30*45	1.56
9765	35*47	1.56
9766	32*48	1.56
9767	36*48	1.56
9768	30*50	1.68
9769	31.7*50.3*7.7	1.68
9770	35*50	1.68
9771	36*50	1.68
9772	32*52	1.68
9773	36*52	1.68
9774	35*55	1.8
9775	36*56	1.8
9776	38.1*51.5	1.68
9777	40*52	1.68
9778	40*55	1.8
9779	40*60	2.04
9780	45*59	2.04
9781	45*60	2.04
9782	45*65	2.28
9783	48*63	2.16
9784	50*65	2.16
9785	50*70	2.4
9786	51*67	2.28
9787	52*68	2.28
9788	55*70	2.4
9789	56*71	2.4
9790	50*75	2.52
9791	55*75	2.52
9792	63*78	2.52
9793	50*80	3
9794	55*80	2.76
9795	58*80	2.76
9796	60*80	2.76
9797	62*80	2.76
9798	65*80	2.76
9799	65*85	3
9800	65*90	3.12
9801	66*88*9	3
9802	70*85	3
9803	70*90	3.12
9804	75*90	3.12
9805	72*92	3.12
9806	72*90	3.12
9807	70*95	3.24
9808	75*95	3.24
9809	80*95	3.24
9810	70*100	4.2
9811	75*100	4.2
9812	80*100	4.2
9813	80*105	4.32
9814	85*100	4.2
9815	90*105	4.32
9816	85*105	4.32
9817	90*105	4.32
9818	85*110	4.44
9819	90*110	4.44
9820	90*115	4.56
9821	95*115	4.56

序号	规格	丁腈橡胶单价
NO.	SPECIFICATION	NBR PRICE
9822	95*120	4.68
9823	100*115	4.56
9824	100*120	4.68
9825	110*125	5.04
9826	100*125	5.04
9827	80*130	5.4
9828	115*130	5.4
9829	105*130	5.4
9830	110*130	5.4
9831	112*132	5.4
9832	105*135	5.52
9833	110*135	5.52
9834	110*140	5.88
9835	115*140	5.88
9836	120*140	5.88
9837	125*140	5.88
9838	115*145	6
9839	125*145	6
9840	120*145	6
9841	120*150	7.2
9842	125*150	7.2
9843	130*150	7.56
9844	125*155	7.56
9845	140*155	7.8
9846	130*160	7.8
9847	135*160	7.8
9848	140*160	8.4
9849	140*165	8.4
9850	135*165	8.4
9851	140*170	8.4
9852	145*170	8.88
9853	145*175	8.88
9854	150*175	8.88
9855	150*170	8.88
9856	155*175	8.88
9857	150*180	9.12
9858	160*180	9.24
9859	160*185	9.36
9860	160*190	9.24
9861	165*190	9.36
9862	170*195	9.36
9863	160*200	11.64
9864	170*200	10.8
9865	175*205	11.4
9866	180*205	11.4
9867	180*200	10.8
9868	180*210	12
9869	190*220	12.6
9870	200*220	12.6
9871	200*230	13.2
9872	215*230	13.2
9873	210*240	13.56
9874	220*250	14.04
9875	225*250	14.04
9876	225*255	14.4
9877	230*260	14.88
9878	240*270	15.84
9879	250*280	16.32
9880	250*290	16.8
9881	260*290	16.8

序号	规格	丁腈橡胶单价
NO.	SPECIFICATION	NBR PRICE
9882	270*300	17.4
9883	280*310	17.76
9884	290*320	18.6
9885	291*321.5	18.6
9886	300*330	21
9887	310*350	25.2
9888	320*360	30
9889	330*360	30
9890	335*370	31.2
9891	340*380	32.4
9892	350*380	32.4
9893	345*385	31.8
9894	350*390	33.6
9895	360*390	34.8
9896	360*400	34.8
9897	375*407	34.8
9898	380*420	36
9899	400*440	37.2
9900	420*450*12	36
9901	420*460	39.6
9902	425*460	39.6
9903	425*465	40.8
9904	440*480	42
9905	450*490	44.4
9906	480*510	48
9907	500*540	66
9908	530*560	69.6
9909	560*600	76.8
9910	560*610	81.6
9911	580*620	84
9912	600*640	87.6
9913	630*670	90
9914	650*690	96
9915	710*750	104.4
9916	720*760	106.8
9917	720*770	108
9918	730*780	108
9919	750*800	114
9920	800*850	120
9921	820*870	132
9922	870*910	144
9923	840*900	144
9924	900*950	156
9925	940*990	168
9926	950*990	162
9927	980*1024*20	180
9928	1000*1050*25	192
9929	1020*1070*25	216
9930	1080*1120*20	240
9931	1350*1400*25	360

现货O-型圈 O-RING IN STOCK

O型圈

O-RING



序号	规格	丁腈橡胶单价RMB	氟橡胶单价RMB
NO.	SPECIFICATION	NBR PRICE	FKM PRICE
1	6.00*6.60*0.30	0.354	
2	7.00*7.60*0.30	0.355	
3	0.65*1.45*0.40	0.355	
4	0.80*1.60*0.40	0.354	
5	15.00*15.80*0.40	0.605	
6	0.60*1.50*0.45	0.355	
7	0.70*1.70*0.50	0.354	
8	1.00*2.00*0.50	0.355	
9	1.50*2.50*0.50	0.358	
10	1.80*2.80*0.50	0.358	
11	2.00*3.00*0.50	0.361	
12	2.30*3.30*0.50	0.366	
13	2.40*3.40*0.50	0.366	
14	2.50*3.50*0.50	0.366	
15	3.00*4.00*0.50	0.368	
16	3.50*4.50*0.50	0.371	
17	4.00*5.00*0.50	0.374	
18	4.50*5.50*0.50	0.374	
19	6.00*7.00*0.50	0.376	
20	7.00*8.00*0.50	0.379	
21	8.00*9.00*0.50	0.385	
22	8.50*9.50*0.50	0.388	
23	9.00*10.00*0.50	0.39	
24	11.00*12.00*0.50	0.393	
25	12.00*13.00*0.50	0.395	
26	13.50*14.50*0.50	0.398	
27	15.00*16.00*0.50	0.408	
28	20.00*21.00*0.50	0.475	
29	23.50*24.50*0.50	0.48	
30	25.00*26.00*0.50	0.591	
31	30.00*31.00*0.50	0.706	
32	39.50*40.50*0.50	0.842	
33	60.00*61.00*0.50	1.178	
34	1.40*2.60*0.60	0.412	
35	1.50*2.70*0.60	0.414	
36	1.80*3.00*0.60	0.413	
37	2.20*3.40*0.60	0.412	
38	2.40*3.60*0.60	0.414	
39	2.80*4.00*0.60	0.412	
40	3.00*4.20*0.60	0.412	
41	5.50*6.70*0.60	0.412	
42	6.00*7.20*0.60	0.413	
43	6.50*7.70*0.60	0.414	
44	15.00*16.20*0.60	0.591	
45	27.00*28.20*0.60	1.178	
46	31.80*33.00*0.60	1.179	
47	0.56*1.88*0.66	0.336	
48	1.85*3.17*0.66	0.46	
49	1.60*3.00*0.70	0.413	
50	1.80*3.20*0.70	0.413	
51	2.30*3.70*0.70	0.412	
52	3.00*4.40*0.70	0.412	
53	4.00*5.40*0.70	0.417	
54	6.20*7.60*0.70	0.427	
55	7.00*8.40*0.70	0.429	
56	28.00*29.40*0.70	1.184	
57	1.50*3.00*0.75	0.442	
58	2.50*4.00*0.75	0.447	
59	3.00*4.50*0.75	0.453	
60	6.00*7.50*0.75	0.64	
61	8.51*10.09*0.79	0.733	

序号	规格	丁腈橡胶单价RMB	氟橡胶单价RMB
NO.	SPECIFICATION	NBR PRICE	FKM PRICE
62	0.90*2.50*0.80	0.458	
63	1.00*2.60*0.80	0.461	
64	1.40*3.00*0.80	0.468	
65	1.80*3.40*0.80	0.47	
66	2.00*3.60*0.80	0.475	
67	2.20*3.80*0.80	0.477	
68	2.40*4.00*0.80	0.483	
69	2.70*4.30*0.80	0.491	
70	2.90*4.50*0.80	0.499	
71	3.50*5.10*0.80	0.51	
72	4.50*6.10*0.80	0.514	
73	5.00*6.60*0.80	0.516	
74	5.20*6.80*0.80	0.517	
75	6.00*7.60*0.80	0.532	
76	6.40*8.00*0.80	0.543	
77	6.65*8.25*0.80	0.562	
78	7.00*8.60*0.80	0.568	
79	7.40*9.00*0.80	0.575	
80	7.90*9.50*0.80	0.586	
81	10.20*11.80*0.80	0.593	
82	10.70*12.30*0.80	0.62	
83	12.00*13.60*0.80	0.621	
84	12.60*14.20*0.80	0.65	
85	16.40*18.00*0.80	0.834	
86	24.90*26.50*0.80	1.178	
87	29.00*30.60*0.80	1.205	
88	31.20*32.80*0.80	1.294	
89	58.00*59.60*0.80	2.377	
90	9.55*11.35*0.90	0.535	
91	2.01*3.95*0.97	0.236	
92	0.50*2.50*1.00	0.442	0.45
93	0.60*2.60*1.00	0.472	0.48
94	1.00*3.00*1.00	0.191	0.382
95	1.20*3.20*1.00	0.191	0.382
96	1.50*3.50*1.00	0.191	0.382
97	1.70*3.70*1.00	0.193	0.386
98	1.80*3.80*1.00	0.194	0.388
99	2.00*4.00*1.00	0.2	0.4
100	2.20*4.20*1.00	0.2	0.4
101	2.50*4.50*1.00	0.2	0.4
102	2.60*4.60*1.00	0.206	0.412
103	2.90*4.90*1.00	0.214	0.428
104	3.00*5.00*1.00	0.215	0.43
105	3.50*5.50*1.00	0.215	0.43
106	4.00*6.00*1.00	0.215	0.43
107	4.50*6.50*1.00	0.217	0.44
108	5.00*7.00*1.00	0.222	0.44
109	5.20*7.20*1.00	0.222	0.44
110	5.50*7.50*1.00	0.225	0.459
111	6.00*8.00*1.00	0.226	0.468
112	6.50*8.50*1.00	0.233	0.459
113	7.00*9.00*1.00	0.239	0.438
114	7.50*9.50*1.00	0.243	0.44
115	8.00*10.00*1.00	0.247	0.44
116	8.30*10.30*1.00	0.255	0.44
117	8.50*10.50*1.00	0.261	0.49
118	8.90*10.90*1.00	0.262	0.497
119	9.00*11.00*1.00	0.263	0.65
120	9.50*11.50*1.00	0.263	0.65
121	10.00*12.00*1.00	0.263	0.65
122	10.50*12.50*1.00	0.274	0.65
123	11.00*13.00*1.00	0.286	0.65
124	11.30*13.30*1.00	0.294	0.65
125	11.50*13.50*1.00	0.298	0.65
126	12.00*14.00*1.00	0.31	0.772
127	12.50*14.50*1.00	0.315	0.761
128	13.00*15.00*1.00	0.317	0.761
129	14.00*16.00*1.00	0.34	0.761
130	14.50*16.50*1.00	0.351	0.752
131	15.00*17.00*1.00	0.363	0.846
132	15.50*17.50*1.00	0.374	0.846
133	16.00*18.00*1.00	0.385	0.846
134	16.50*18.50*1.00	0.397	0.886

序号	规格	丁腈橡胶单价RMB	氟橡胶单价RMB
NO.	SPECIFICATION	NBR PRICE	FKM PRICE
135	17.00*19.00*1.00	0.408	0.844
136	17.50*19.50*1.00	0.419	0.96
137	18.00*20.00*1.00	0.431	1.004
138	19.00*21.00*1.00	0.439	1.127
139	19.50*21.50*1.00	0.445	1.127
140	20.00*22.00*1.00	0.451	1.18
141	20.50*22.50*1.00	0.468	1.178
142	21.00*23.00*1.00	0.473	1.178
143	21.50*23.50*1.00	0.483	1.178
144	22.00*24.00*1.00	0.494	1.152
145	22.50*24.50*1.00	0.505	1.178
146	23.00*25.00*1.00	0.515	1.127
147	24.00*26.00*1.00	0.537	1.312
148	24.50*26.50*1.00	0.548	1.312
149	25.00*27.00*1.00	0.558	1.352
150	25.50*27.50*1.00	0.569	1.4
151	26.00*28.00*1.00	0.58	1.452
152	27.00*29.00*1.00	0.601	1.452
153	28.00*30.00*1.00	0.623	1.556
154	29.00*31.00*1.00	0.644	1.556
155	30.00*32.00*1.00	0.666	1.523
156	31.00*33.00*1.00	0.687	1.523
157	31.50*33.50*1.00	0.698	1.523
158	32.00*34.00*1.00	0.709	1.524
159	33.00*35.00*1.00	0.73	1.605
160	34.00*36.00*1.00	0.752	1.605
161	35.00*37.00*1.00	0.773	1.749
162	36.00*38.00*1.00	0.795	1.749
163	37.00*39.00*1.00	0.816	1.749
164	38.00*40.00*1.00	0.838	1.749
165	38.50*40.50*1.00	0.848	1.878
166	39.00*41.00*1.00	0.859	1.895
167	39.50*41.50*1.00	0.87	2.138
168	40.00*42.00*1.00	0.881	2.138
169	41.00*43.00*1.00	0.902	2.163
170	42.00*44.00*1.00	0.924	2.415
171	43.00*45.00*1.00	0.945	2.433
172	44.00*46.00*1.00	0.966	2.542
173	45.00*47.00*1.00	0.988	2.651
174	46.00*48.00*1.00	1.009	2.651
175	47.00*49.00*1.00	1.031	2.651
176	48.00*50.00*1.00	1.052	2.651
177	49.00*51.00*1.00	1.074	2.651
178	50.00*52.00*1.00	1.095	2.781
179	51.00*53.00*1.00	1.117	2.781
180	52.00*54.00*1.00	1.138	2.88
181	53.00*55.00*1.00	1.16	3.242
182	54.00*56.00*1.00	1.181	3.292
183	55.00*57.00*1.00	1.203	3.442
184	56.00*58.00*1.00	1.224	3.541
185	57.00*59.00*1.00	1.246	3.841
186	58.00*60.00*1.00	1.267	3.869
187	59.00*61.00*1.00	1.36	3.913
188	60.00*62.00*1.00	1.456	4.132
189	61.00*63.00*1.00	1.775	4.015
190	82.00*84.00*1.00	2.971	6.299
191	90.00*92.00*1.00	3.257	7.813
192	123.00*125.00*1.00	3.8	17.287
193	0.74*2.78*1.02	0.17	0.34
194	1.78*3.82*1.02	0.174	0.348
195	3.20*5.24*1.02	0.178	0.356
196	4.57*6.61*1.02	0.18	0.36
197	2.79*4.97*1.09	0.22	0.44
198	77.16*79.40*1.12	2.343	6.486
199	2.29*4.67*1.19	0.176	0.352
200	2.10*4.50*1.20	0.181	0.362
201	2.50*4.90*1.20	0.191	0.382
202	2.60*5.00*1.20	0.193	0.386
203	2.80*5.20*1.20	0.196	0.392
204	3.30*5.70*1.20	0.198	0.396
205	3.50*5.90*1.20	0.2	0.4
206	4.00*6.40*1.20	0.205	0.41

现货O-型圈 O-RING IN STOCK

序号	规格	丁腈橡胶单价RMB	氟橡胶单价RMB
NO.	SPECIFICATION	NBR PRICE	FKM PRICE
207	4.20*6.60*1.20	0.213	0.426
208	4.50*6.90*1.20	0.206	0.412
209	4.80*7.20*1.20	0.208	0.416
210	5.00*7.40*1.20	0.209	0.418
211	6.00*8.40*1.20	0.21	0.42
212	7.00*9.40*1.20	0.211	0.459
213	7.50*9.90*1.20	0.212	0.437
214	8.00*10.40*1.20	0.213	0.531
215	9.00*11.40*1.20	0.214	0.598
216	9.50*11.90*1.20	0.215	0.608
217	10.00*12.40*1.20	0.25	0.735
218	11.00*13.40*1.20	0.26	0.735
219	12.00*14.40*1.20	0.27	0.735
220	13.00*15.40*1.20	0.281	0.845
221	14.80*17.20*1.20	0.363	1.115
222	15.80*18.20*1.20	0.377	1.115
223	16.50*18.90*1.20	0.383	1.115
224	16.80*19.20*1.20	0.384	1.115
225	17.00*19.40*1.20	0.394	1.115
226	17.80*20.20*1.20	0.42	1.206
227	19.00*21.40*1.20	0.43	1.285
228	23.80*26.20*1.20	0.44	1.59
229	26.00*28.40*1.20	0.486	1.871
230	37.00*39.40*1.20	0.594	2.535
231	43.50*45.90*1.20	0.691	2.963
232	48.00*50.40*1.20	0.862	3.361
233	54.00*56.40*1.20	1.068	4.19
234	56.00*58.40*1.20	1.196	4.655
235	67.60*70.00*1.20	2.16	5.555
236	69.60*71.00*1.20	2.16	5.609
237	3.86*6.34*1.24	0.234	0.308
238	12.90*15.38*1.24	0.363	0.308
239	1.12*3.68*1.25	0.172	0.308
240	3.00*5.50*1.25	0.186	0.388
241	10.75*13.25*1.25	0.313	0.84
242	16.00*18.50*1.25	0.45	1.033
243	1.07*3.61*1.27	0.225	0.285
244	8.38*10.92*1.27	0.409	0.721
245	28.55*31.09*1.27	0.597	1.999
246	29.82*32.36*1.27	0.622	2.041
247	33.43*35.97*1.27	0.695	2.622
248	34.67*37.21*1.27	0.719	2.377
249	185.19*187.73*1.27	3.588	19.145
250	1.50*4.10*1.30	0.181	0.362
251	2.00*4.60*1.30	0.186	0.372
252	2.45*5.05*1.30	0.189	0.378
253	2.60*5.20*1.30	0.192	0.384
254	3.40*6.00*1.30	0.195	0.39
255	3.70*6.30*1.30	0.198	0.396
256	3.90*6.50*1.30	0.201	0.402
257	4.70*7.30*1.30	0.203	0.406
258	5.40*8.00*1.30	0.207	0.417
259	6.00*8.60*1.30	0.21	0.462
260	6.40*9.00*1.30	0.214	0.46
261	7.30*9.90*1.30	0.219	0.483
262	8.00*10.60*1.30	0.221	0.538
263	9.40*12.00*1.30	0.242	0.581
264	10.00*12.60*1.30	0.248	0.63
265	10.40*13.00*1.30	0.25	0.63
266	11.00*13.60*1.30	0.253	0.641
267	13.60*16.20*1.30	0.255	0.82
268	13.89*16.49*1.30	0.276	1.021
269	14.00*16.60*1.30	0.309	1.033
270	15.20*17.80*1.30	0.306	1.033
271	17.40*20.00*1.30	0.313	1.508
272	24.00*26.60*1.30	0.612	1.575
273	29.40*32.00*1.30	0.743	1.924
274	36.40*39.00*1.30	0.912	2.186
275	37.40*40.00*1.30	0.936	2.186
276	1.20*4.00*1.40	0.182	0.247
277	1.80*4.60*1.40	0.187	0.247
278	2.17*4.97*1.40	0.19	0.327

序号	规格	丁腈橡胶单价RMB	氟橡胶单价RMB
NO.	SPECIFICATION	NBR PRICE	FKM PRICE
279	2.50*5.30*1.40	0.193	0.328
280	2.80*5.60*1.40	0.195	0.323
281	3.20*6.00*1.40	0.196	0.341
282	3.80*6.60*1.40	0.198	0.424
283	4.20*7.00*1.40	0.199	0.425
284	5.20*8.00*1.40	0.2	0.498
285	5.70*8.50*1.40	0.203	0.558
286	6.00*8.80*1.40	0.208	0.558
287	6.20*9.00*1.40	0.21	0.558
288	6.70*9.50*1.40	0.212	0.558
289	7.20*10.00*1.40	0.22	0.71
290	7.80*10.60*1.40	0.215	0.711
291	8.00*10.80*1.40	0.22	0.711
292	9.00*11.80*1.40	0.221	0.711
293	9.20*12.00*1.40	0.23	0.711
294	9.70*12.50*1.40	0.223	0.711
295	10.00*12.80*1.40	0.229	0.711
296	10.20*13.00*1.40	0.23	0.799
297	10.40*13.20*1.40	0.232	0.799
298	11.80*14.60*1.40	0.25	0.848
299	17.00*19.80*1.40	0.361	1.127
300	30.10*32.90*1.40	0.634	1.762
301	60.00*62.80*1.40	2.01	5.295
302	67.00*69.80*1.40	2.112	5.441
303	70.00*72.80*1.40	2.204	6.672
304	71.40*74.20*1.40	2.247	7.346
305	88.30*91.10*1.40	2.5	8.735
306	90.20*93.00*1.40	2.828	9.025
307	4.70*7.54*1.42	0.224	0.349
308	15.49*18.43*1.47	0.367	1.505
309	1.00*4.00*1.50	0.123	0.169
310	1.50*4.50*1.50	0.125	0.169
311	2.00*5.00*1.50	0.127	0.172
312	2.50*5.50*1.50	0.129	0.296
313	2.60*5.60*1.50	0.13	0.234
314	3.00*6.00*1.50	0.131	0.305
315	3.50*6.50*1.50	0.136	0.385
316	4.00*7.00*1.50	0.14	0.423
317	4.50*7.50*1.50	0.142	0.412
318	5.00*8.00*1.50	0.146	0.412
319	5.50*8.50*1.50	0.15	0.546
320	6.00*9.00*1.50	0.153	0.446
321	6.50*9.50*1.50	0.157	0.59
322	7.00*10.00*1.50	0.161	0.683
323	7.50*10.50*1.50	0.163	0.68
324	8.00*11.00*1.50	0.166	0.68
325	8.20*11.20*1.50	0.169	0.68
326	8.50*11.50*1.50	0.203	0.778
327	9.00*12.00*1.50	0.204	0.826
328	9.50*12.50*1.50	0.219	0.826
329	10.00*13.00*1.50	0.226	0.936
330	10.50*13.50*1.50	0.183	0.936
331	10.70*13.70*1.50	0.184	0.936
332	11.00*14.00*1.50	0.186	0.936
333	11.50*14.50*1.50	0.189	0.936
334	12.00*15.00*1.50	0.289	1.126
335	12.50*15.50*1.50	0.248	1.126
336	13.00*16.00*1.50	0.231	1.126
337	13.50*16.50*1.50	0.259	1.126
338	14.00*17.00*1.50	0.262	1.126
339	14.50*17.50*1.50	0.267	1.126
340	15.00*18.00*1.50	0.276	1.126
341	15.50*18.50*1.50	0.295	1.126
342	16.00*19.00*1.50	0.315	1.225
343	16.50*19.50*1.50	0.324	1.251
344	17.00*20.00*1.50	0.362	1.469
345	17.50*20.50*1.50	0.337	1.469
346	18.00*21.00*1.50	0.395	1.469
347	18.50*21.50*1.50	0.354	1.469
348	19.00*22.00*1.50	0.441	1.4
349	19.50*22.50*1.50	0.354	1.4
350	20.00*23.00*1.50	0.474	1.923

序号	规格	丁腈橡胶单价RMB	氟橡胶单价RMB
NO.	SPECIFICATION	NBR PRICE	FKM PRICE
351	20.50*23.50*1.50	0.349	1.923
352	21.00*24.00*1.50	0.45	2.051
353	21.50*24.50*1.50	0.375	2.051
354	22.00*25.00*1.50	0.521	2.177
355	22.50*25.50*1.50	0.395	2.177
356	23.00*26.00*1.50	0.485	2.209
357	23.50*26.50*1.50	0.419	2.209
358	24.00*27.00*1.50	0.579	2.186
359	24.50*27.50*1.50	0.473	2.186
360	25.00*28.00*1.50	0.473	2.186
361	26.00*29.00*1.50	0.588	2.36
362	26.50*29.50*1.50	0.512	2.063
363	27.00*30.00*1.50	0.542	2.063
364	27.50*30.50*1.50	0.518	2.098
365	28.00*31.00*1.50	0.542	2.138
366	28.50*31.50*1.50	0.555	2.312
367	29.00*32.00*1.50	0.556	2.312
368	29.50*32.50*1.50	0.559	2.473
369	30.00*33.00*1.50	0.586	2.473
370	30.50*33.50*1.50	0.569	2.645
371	31.00*34.00*1.50	0.64	2.892
372	31.50*34.50*1.50	0.584	2.892
373	32.00*35.00*1.50	0.596	2.892
374	32.50*35.50*1.50	0.605	2.892
375	33.00*36.00*1.50	0.614	2.892
376	33.50*36.50*1.50	0.62	2.892
377	34.00*37.00*1.50	0.627	2.892
378	34.50*37.50*1.50	0.631	2.892
379	35.00*38.00*1.50	0.641	2.892
380	35.50*38.50*1.50	0.686	2.863
381	36.00*39.00*1.50	0.695	2.863
382	36.50*39.50*1.50	0.702	2.863
383	37.00*40.00*1.50	0.709	2.863
384	37.50*40.50*1.50	0.715	3.398
385	38.00*41.00*1.50	0.721	3.01
386	38.50*41.50*1.50	0.728	2.933
387	39.00*42.00*1.50	0.736	3.01
388	39.50*42.50*1.50	0.745	3.01
389	40.00*43.00*1.50	0.829	3.036
390	41.00*44.00*1.50	0.849	3.326
391	42.00*45.00*1.50	0.98	3.088
392	43.00*46.00*1.50	1.099	3.415
393	44.00*47.00*1.50	1.124	3.306
394	45.00*48.00*1.50	1.216	3.742
395	46.00*49.00*1.50	1.208	3.742
396	47.00*50.00*1.50	1.233	3.742
397	47.50*50.50*1.50	1.335	3.742
398	48.00*51.00*1.50	1.348	3.742
399	49.00*52.00*1.50	1.376	4.027
400	50.00*53.00*1.50	1.496	4.027
401	53.00*56.00*1.50	1.584	4.663
402	54.00*57.00*1.50	1.714	4.639
403	55.00*58.00*1.50	1.847	4.414
404	57.00*60.00*1.50	1.912	5.004
405	58.00*61.00*1.50	2.053	5.004
406	59.00*62.00*1.50	2.088	5.295
407	60.00*63.00*1.50	2.346	5.441
408	62.00*65.00*1.50	2.376	5.732
409	62.50*65.50*1.50	2.394	5.295
410	63.00*66.00*1.50	2.413	5.004
411	64.00*67.00*1.50	2.427	5.877
412	65.00*68.00*1.50	2.482	5.877
413	66.00*69.00*1.50	2.501	5.731
414	67.00*70.00*1.50	2.538	5.731
415	68.00*71.00*1.50	2.55	5.877
416	69.00*72.00*1.50	2.586	6.648
417	70.00*73.00*1.50	2.623	6.648
418	71.00*74.00*1.50	2.765	6.648
419	71.50*74.50*1.50	2.917	6.648
420	72.00*75.00*1.50	3.07	6.997
421	73.00*76.00*1.50	3.115	8.044
422	75.00*78.00*1.50	3.195	8.044

现货O-型圈 O-RING IN STOCK

序号	规格	丁腈橡胶单价RMB	氟橡胶单价RMB
NO.	SPECIFICATION	NBR PRICE	FKM PRICE
423	76.00*79.00*1.50	3.3	8.044
424	77.00*80.00*1.50	3.309	8.044
425	78.00*81.00*1.50	3.321	8.044
426	79.00*82.00*1.50	3.355	8.74
427	80.00*83.00*1.50	3.375	8.742
428	81.00*84.00*1.50	3.422	8.742
429	82.00*85.00*1.50	3.488	8.742
430	83.00*86.00*1.50	3.555	9.44
431	85.00*88.00*1.50	3.613	9.44
432	90.00*93.00*1.50	3.722	10.169
433	92.00*95.00*1.50	3.736	10.169
434	93.00*96.00*1.50	3.736	10.431
435	94.00*97.00*1.50	3.746	10.605
436	95.00*98.00*1.50	3.749	10.78
437	96.00*99.00*1.50	3.752	10.78
438	97.00*100.00*1.50	3.757	10.78
439	98.00*101.00*1.50	3.781	10.78
440	100.00*103.00*1.50	3.797	11.478
441	1.42*4.46*1.52	0.186	0.372
442	1.78*4.82*1.52	0.187	0.374
443	1.80*5.00*1.60	0.188	0.376
444	2.20*5.40*1.60	0.189	0.378
445	2.30*5.50*1.60	0.19	0.38
446	2.50*5.70*1.60	0.19	0.38
447	2.57*5.77*1.60	0.19	0.38
448	2.80*6.00*1.60	0.191	0.382
449	2.90*6.10*1.60	0.192	0.384
450	3.10*6.30*1.60	0.193	0.386
451	3.20*6.40*1.60	0.194	0.388
452	3.40*6.60*1.60	0.194	0.388
453	3.55*6.75*1.60	0.194	0.388
454	3.70*6.90*1.60	0.194	0.388
455	4.00*7.20*1.60	0.194	0.388
456	4.70*7.90*1.60	0.197	0.394
457	4.80*8.00*1.60	0.198	0.396
458	5.10*8.30*1.60	0.2	0.4
459	5.80*9.00*1.60	0.201	0.45
460	6.30*9.50*1.60	0.203	0.491
461	6.50*9.70*1.60	0.205	0.458
462	6.80*10.00*1.60	0.206	0.546
463	7.00*10.20*1.60	0.208	0.529
464	7.10*10.30*1.60	0.21	0.663
465	7.60*10.80*1.60	0.212	0.663
466	8.00*11.20*1.60	0.212	0.663
467	8.10*11.30*1.60	0.214	0.663
468	9.00*12.20*1.60	0.216	0.663
469	9.50*12.70*1.60	0.218	0.772
470	10.10*13.30*1.60	0.221	0.718
471	10.80*14.00*1.60	0.234	0.778
472	11.10*14.30*1.60	0.242	0.754
473	11.60*14.80*1.60	0.249	0.826
474	11.90*15.10*1.60	0.255	1.045
475	12.00*15.20*1.60	0.257	1.045
476	12.80*16.00*1.60	0.272	1.045
477	13.20*16.40*1.60	0.279	1.045
478	15.80*19.00*1.60	0.328	1.195
479	17.10*20.30*1.60	0.353	1.397
480	19.00*22.20*1.60	0.389	1.444
481	20.10*23.30*1.60	0.405	1.868
482	21.10*24.30*1.60	0.412	1.896
483	25.00*28.20*1.60	0.502	1.836
484	27.10*30.30*1.60	0.541	2.186
485	29.00*32.20*1.60	0.577	2.332
486	31.50*34.70*1.60	0.624	2.423
487	32.10*35.30*1.60	0.655	2.874
488	35.10*38.30*1.60	0.689	3.149
489	37.00*40.20*1.60	0.728	3.073
490	54.00*57.20*1.60	1.469	4.958
491	80.00*83.20*1.60	2.679	8.742
492	86.00*89.20*1.60	3.041	8.742
493	14.96*18.20*1.62	0.286	1.19
494	6.07*9.33*1.63	0.205	0.541

序号	规格	丁腈橡胶单价RMB	氟橡胶单价RMB
NO.	SPECIFICATION	NBR PRICE	FKM PRICE
495	97.79*101.05*1.63	3.582	15.363
496	4.50*7.80*1.65	0.22	0.422
497	16.00*19.30*1.65	0.405	2.029
498	76.00*79.30*1.65	1.888	8.03
499	65.04*68.40*1.68	2.1	6.75
500	5.10*8.50*1.70	0.229	0.761
501	9.00*12.40*1.70	0.25	0.908
502	10.00*13.40*1.70	0.28	1.286
503	32.00*35.40*1.70	0.718	3.095
504	160.00*163.40*1.70	7.137	22.431
505	131.5*134.94*1.72	4.888	20.664
506	16.00*19.50*1.75	0.36	2.006
507	113.50*117.00*1.75	3.8	12.598
508	68*71.54*1.77	1.88	7.987
509	1.78*5.34*1.78	0.154	0.309
510	2.57*6.13*1.78	0.158	0.407
511	2.90*6.46*1.78	0.162	0.433
512	3.68*7.24*1.78	0.166	0.433
513	3.94*7.50*1.78	0.169	0.433
514	4.47*8.03*1.78	0.149	0.437
515	4.76*8.32*1.78	0.15	0.571
516	4.87*8.43*1.78	0.15	0.571
517	5.12*8.68*1.78	0.153	0.571
518	5.28*8.84*1.78	0.153	0.571
519	6.07*9.63*1.78	0.175	0.571
520	6.35*9.91*1.78	0.178	0.574
521	6.75*10.31*1.78	0.187	0.743
522	7.65*11.21*1.78	0.212	0.868
523	7.80*11.36*1.78	0.164	0.868
524	7.95*11.51*1.78	0.172	0.868
525	8.24*11.80*1.78	0.183	0.868
526	8.73*12.29*1.78	0.248	0.976
527	9.25*12.81*1.78	0.207	0.976
528	9.75*13.31*1.78	0.217	0.976
529	10.82*14.38*1.78	0.312	0.976
530	11.10*14.66*1.78	0.223	0.976
531	11.20*14.76*1.78	0.232	0.99
532	11.30*14.86*1.78	0.227	0.94
533	11.80*15.36*1.78	0.227	0.998
534	11.91*15.47*1.78	0.227	0.94
535	12.42*15.98*1.78	0.276	1.347
536	13.30*16.86*1.78	0.28	1.347
537	14.00*17.56*1.78	0.291	1.347
538	14.80*18.36*1.78	0.313	1.347
539	15.00*18.56*1.78	0.29	1.347
540	15.60*19.16*1.78	0.458	1.641
541	16.67*20.23*1.78	0.375	1.641
542	17.17*20.73*1.78	0.362	1.641
543	17.70*21.26*1.78	0.395	1.641
544	18.77*22.33*1.78	0.395	1.641
545	19.15*22.71*1.78	0.425	1.641
546	19.50*23.06*1.78	0.458	1.749
547	20.35*23.91*1.78	0.468	1.724
548	21.95*25.51*1.78	0.479	1.942
549	23.52*27.08*1.78	0.579	2.325
550	24.09*27.65*1.78	0.503	2.325
551	25.12*28.68*1.78	0.518	2.338
552	26.70*30.26*1.78	0.549	2.491
553	28.30*31.86*1.78	0.58	3.351
554	29.87*33.43*1.78	0.581	3.472
555	31.47*35.03*1.78	0.589	3.472
556	32.00*35.56*1.78	0.644	3.472
557	33.05*36.61*1.78	0.624	3.472
558	34.65*38.21*1.78	0.655	3.472
559	36.00*39.56*1.78	0.67	3.472
560	36.27*39.83*1.78	0.727	3.398
561	37.82*41.38*1.78	0.727	3.471
562	39.45*43.01*1.78	0.802	4.157
563	41.00*44.56*1.78	0.825	4.157
564	43.75*47.31*1.78	1.004	4.397
565	44.17*47.73*1.78	0.909	4.069
566	45.84*49.40*1.78	1.004	4.833

序号	规格	丁腈橡胶单价RMB	氟橡胶单价RMB
NO.	SPECIFICATION	NBR PRICE	FKM PRICE
567	47.35*50.91*1.78	1.023	4.833
568	47.60*51.16*1.78	1.061	5.422
569	50.52*54.08*1.78	1.22	5.575
570	53.57*57.13*1.78	1.347	5.295
571	53.70*57.26*1.78	1.448	6.423
572	56.87*60.43*1.78	1.448	6.423
573	60.05*63.61*1.78	1.448	6.768
574	63.22*66.78*1.78	1.55	6.768
575	66.40*69.96*1.78	1.798	6.703
576	69.57*73.13*1.78	1.98	8.013
577	72.75*76.31*1.78	2.073	8.013
578	74.93*78.49*1.78	2.134	8.013
579	75.92*79.48*1.78	2.012	8.088
580	79.00*82.56*1.78	2.134	8.306
581	82.27*85.83*1.78	2.497	8.306
582	85.34*88.90*1.78	3.107	10.605
583	88.62*92.18*1.78	3.031	10.605
584	91.00*94.56*1.78	3.052	11.042
585	91.70*95.26*1.78	3.069	10.823
586	94.97*98.53*1.78	3.095	10.387
587	98.05*101.61*1.78	3.107	11.042
588	100.00*103.56*1.78	3.155	11.221
589	101.32*104.88*1.78	3.258	11.478
590	104.40*107.96*1.78	3.258	12.569
591	107.67*111.23*1.78	3.702	14.708
592	110.74*114.30*1.78	3.806	14.708
593	114.02*117.58*1.78	3.816	15.799
594	117.10*120.66*1.78	3.918	15.363
595	120.37*123.93*1.78	4.238	15.363
596	123.44*127.00*1.78	4.355	16.89
597	126.72*130.28*1.78	4.458	16.89
598	129.40*132.96*1.78	4.715	16.89
599	133.07*136.63*1.78	5.146	16.89
600	135.76*139.32*1.78	6.263	18.854
601	138.94*142.50*1.78	6.407	18.488
602	142.11*145.67*1.78	6.552	19.242
603	145.29*148.85*1.78	6.697	19.242
604	148.46*152.02*1.78	6.841	19.242
605	151.64*155.20*1.78	6.986	21.039
606	154.81*158.37*1.78	7.13	21.214
607	158.00*161.56*1.78	7.275	21.912
608	161.16*164.72*1.78	7.419	24.792
609	164.34*167.90*1.78	7.564	26.712
610	167.51*171.07*1.78	7.708	26.712
611	170.00*173.56*1.78	7.853	26.712
612	170.69*174.25*1.78	7.853	26.712
613	185.19*188.75*1.78	8.513	26.887
614	150.5*154.08*1.79	7.02	24.278
615	1.80*5.40*1.80	0.16	0.327
616	2.00*5.60*1.80	0.16	0.351
617	2.24*5.84*1.80	0.16	0.362
618	2.50*6.10*1.80	0.16	0.387
619	2.70*6.30*1.80	0.162	0.385
620	2.80*6.40*1.80	0.163	0.407
621	2.90*6.50*1.80	0.163	0.457
622	3.00*6.60*1.80	0.164	0.416
623	3.10*6.70*1.80	0.165	0.406
624	3.15*6.75*1.80	0.165	0.446
625	3.30*6.90*1.80	0.166	0.475
626	3.50*7.10*1.80	0.166	0.475
627	3.55*7.15*1.80	0.166	0.482
628	3.75*7.35*1.80	0.17	0.457
629	4.00*7.60*1.80	0.175	0.515
630	4.20*7.80*1.80	0.176	0.52
631	4.30*7.90*1.80	0.168	0.52
632	4.50*8.10*1.80	0.151	0.563
633	4.87*8.47*1.80	0.152	0.585
634	5.00*8.60*1.80	0.152	0.596
635	5.15*8.75*1.80	0.153	0.618
636	5.30*8.90*1.80	0.154	0.632
637	5.50*9.10*1.80	0.157	0.644
638	5.60*9.20*1.80	0.158	0.65

现货O-型圈 O-RING IN STOCK

序号	规格	丁腈橡胶单价RMB	氟橡胶单价RMB
NO.	SPECIFICATION	NBR PRICE	FKM PRICE
639	5.80*9.40*1.80	0.158	0.662
640	6.00*9.60*1.80	0.164	0.71
641	6.30*9.90*1.80	0.166	0.697
642	6.40*10.00*1.80	0.168	0.677
643	6.70*10.30*1.80	0.179	0.772
644	6.80*10.40*1.80	0.179	0.772
645	6.90*10.50*1.80	0.181	0.766
646	7.00*10.60*1.80	0.181	0.801
647	7.10*10.70*1.80	0.181	0.815
648	7.20*10.80*1.80	0.187	0.802
649	7.50*11.10*1.80	0.198	0.832
650	7.90*11.50*1.80	0.202	0.883
651	8.00*11.60*1.80	0.209	0.881
652	8.20*11.80*1.80	0.215	0.876
653	8.30*11.90*1.80	0.22	0.906
654	8.50*12.10*1.80	0.227	0.983
655	8.75*12.35*1.80	0.231	0.947
656	9.00*12.60*1.80	0.236	0.956
657	9.50*13.10*1.80	0.242	1.045
658	9.60*13.20*1.80	0.246	1.077
659	10.00*13.60*1.80	0.253	1.039
660	10.30*13.90*1.80	0.259	1.058
661	10.50*14.10*1.80	0.262	1.081
662	10.60*14.20*1.80	0.264	1.072
663	10.80*14.40*1.80	0.267	1.023
664	11.00*14.60*1.80	0.271	1.037
665	11.20*14.80*1.80	0.275	1.049
666	11.30*14.90*1.80	0.276	1.049
667	11.50*15.10*1.80	0.28	1.049
668	11.80*15.40*1.80	0.281	1.257
669	12.00*15.60*1.80	0.302	1.315
670	12.50*16.10*1.80	0.298	1.315
671	12.80*16.40*1.80	0.271	1.315
672	13.00*16.60*1.80	0.28	1.315
673	13.20*16.80*1.80	0.291	1.315
674	13.50*17.10*1.80	0.291	1.315
675	14.00*17.60*1.80	0.349	1.446
676	14.80*18.40*1.80	0.346	1.423
677	15.00*18.60*1.80	0.362	1.517
678	15.60*19.20*1.80	0.39	1.692
679	16.00*19.60*1.80	0.362	1.644
680	16.50*20.10*1.80	0.4	1.687
681	17.00*20.60*1.80	0.4	1.847
682	17.50*21.10*1.80	0.4	1.847
683	18.00*21.60*1.80	0.471	1.908
684	19.00*22.60*1.80	0.485	2.034
685	19.50*23.10*1.80	0.503	2.011
686	19.90*23.50*1.80	0.518	2.098
687	20.00*23.60*1.80	0.52	2.298
688	20.30*23.90*1.80	0.525	2.317
689	21.00*24.60*1.80	0.537	2.615
690	21.20*24.80*1.80	0.541	2.671
691	21.30*24.90*1.80	0.543	2.793
692	21.70*25.30*1.80	0.55	2.967
693	22.40*26.00*1.80	0.562	3.16
694	23.00*26.60*1.80	0.573	3.16
695	23.20*26.80*1.80	0.576	3.16
696	23.60*27.20*1.80	0.584	3.16
697	24.00*27.60*1.80	0.591	3.16
698	24.60*28.20*1.80	0.601	3.16
699	25.00*28.60*1.80	0.608	3.16
700	25.60*29.20*1.80	0.619	3.275
701	25.80*29.40*1.80	0.623	3.289
702	26.50*30.10*1.80	0.635	3.325
703	27.00*30.60*1.80	0.644	3.228
704	28.00*31.60*1.80	0.662	3.519
705	29.00*32.60*1.80	0.679	3.448
706	30.00*33.60*1.80	0.697	3.467
707	31.00*34.60*1.80	0.715	3.467
708	31.50*35.10*1.80	0.724	3.467
709	32.00*35.60*1.80	0.733	3.622
710	32.50*36.10*1.80	0.741	3.742

序号	规格	丁腈橡胶单价RMB	氟橡胶单价RMB
NO.	SPECIFICATION	NBR PRICE	FKM PRICE
711	33.50*37.10*1.80	0.759	3.796
712	34.00*37.60*1.80	0.768	3.884
713	34.50*38.10*1.80	0.777	3.896
714	35.00*38.60*1.80	0.786	3.913
715	35.50*39.10*1.80	0.795	3.956
716	36.00*39.60*1.80	0.803	4.065
717	36.50*40.10*1.80	0.855	4.137
718	37.50*41.10*1.80	0.876	4.195
719	38.00*41.60*1.80	0.839	4.395
720	38.70*42.30*1.80	0.851	4.52
721	40.00*43.60*1.80	0.874	4.524
722	40.40*44.00*1.80	0.882	4.742
723	41.20*44.80*1.80	0.896	4.524
724	42.00*45.60*1.80	0.91	4.742
725	42.50*46.10*1.80	0.947	4.969
726	43.70*47.30*1.80	0.94	5.151
727	44.00*47.60*1.80	1.004	5.397
728	45.00*48.60*1.80	0.963	5.597
729	46.20*49.80*1.80	1.104	5.776
730	47.00*50.60*1.80	0.999	5.754
731	47.50*51.10*1.80	1.039	5.501
732	48.00*51.60*1.80	1.082	5.651
733	48.70*52.30*1.80	1.104	5.651
734	50.00*53.60*1.80	1.241	6.038
735	51.50*55.10*1.80	1.263	6.162
736	53.00*56.60*1.80	1.293	6.337
737	54.40*58.00*1.80	1.448	6.877
738	55.00*58.60*1.80	1.448	6.877
739	56.00*59.60*1.80	1.398	6.975
740	57.00*60.60*1.80	1.549	7.113
741	58.00*61.60*1.80	1.499	7.193
742	60.00*63.60*1.80	1.549	7.277
743	60.30*63.90*1.80	1.579	7.306
744	61.50*65.10*1.80	1.723	7.332
745	63.00*66.60*1.80	1.759	7.459
746	65.00*68.60*1.80	1.808	7.577
747	66.40*70.00*1.80	1.842	7.742
748	67.00*70.60*1.80	1.942	7.879
749	69.00*72.60*1.80	2.063	8.044
750	69.60*73.20*1.80	2.069	8.162
751	70.50*74.10*1.80	2.077	8.332
752	71.00*74.60*1.80	2.09	8.459
753	73.70*77.30*1.80	2.127	8.559
754	75.00*78.60*1.80	2.126	8.922
755	77.50*81.10*1.80	2.189	9.179
756	80.00*83.60*1.80	2.216	9.644
757	82.00*85.60*1.80	2.34	10.306
758	85.00*88.60*1.80	2.728	11.74
759	86.00*89.60*1.80	2.521	11.74
760	90.00*93.60*1.80	2.628	11.478
761	93.50*97.10*1.80	3.107	11.478
762	94.00*97.60*1.80	3.111	11.478
763	95.00*98.60*1.80	3.258	12.023
764	100.00*103.60*1.80	3.258	13.223
765	102.00*105.60*1.80	3.55	13.223
766	106.00*109.60*1.80	3.633	13.223
767	109.20*112.80*1.80	3.839	14.781
768	112.00*115.60*1.80	4.1	17.829
769	129.00*132.60*1.80	4.64	17.829
770	133.50*137.10*1.80	5.682	19.119
771	152.40*156.00*1.80	7.13	20.786
772	188.00*191.60*1.80	7.733	23.022
773	8.92*12.58*1.83	0.232	0.99
774	10.52*14.18*1.83	0.286	1.134
775	1.20*5.00*1.90	0.247	0.337
776	2.20*6.00*1.90	0.245	0.358
777	2.40*6.20*1.90	0.236	0.408
778	2.60*6.40*1.90	0.249	0.408
779	2.80*6.60*1.90	0.208	0.427
780	2.90*6.70*1.90	0.209	0.449
781	3.20*7.00*1.90	0.21	0.525
782	3.40*7.20*1.90	0.21	0.525

序号	规格	丁腈橡胶单价RMB	氟橡胶单价RMB
NO.	SPECIFICATION	NBR PRICE	FKM PRICE
783	3.50*7.30*1.90	0.211	0.561
784	3.80*7.60*1.90	0.212	0.561
785	4.20*8.00*1.90	0.214	0.613
786	4.80*8.60*1.90	0.215	0.657
787	4.90*8.70*1.90	0.216	0.689
788	5.00*8.80*1.90	0.217	0.659
789	5.20*9.00*1.90	0.217	0.709
790	5.80*9.60*1.90	0.219	0.738
791	6.20*10.00*1.90	0.219	0.794
792	6.40*10.20*1.90	0.219	0.792
793	6.80*10.60*1.90	0.222	0.835
794	7.20*11.00*1.90	0.226	0.946
795	7.80*11.60*1.90	0.233	0.946
796	8.00*11.80*1.90	0.238	1.022
797	8.20*12.00*1.90	0.244	1.007
798	8.80*12.60*1.90	0.258	1.047
799	9.00*12.80*1.90	0.263	1.062
800	9.20*13.00*1.90	0.258	1.06
801	9.50*13.30*1.90	0.275	1.06
802	9.80*13.60*1.90	0.289	1.135
803	10.00*13.80*1.90	0.307	1.251
804	10.20*14.00*1.90	0.313	1.251
805	10.80*14.60*1.90	0.324	1.251
806	11.00*14.80*1.90	0.329	1.28
807	11.20*15.00*1.90	0.34	1.285
808	11.50*15.30*1.90	0.354	1.243
809	12.00*15.80*1.90	0.354	1.365
810	12.20*16.00*1.90	0.373	1.476
811	12.50*16.30*1.90	0.367	1.444
812	13.00*16.80*1.90	0.367	1.603
813	13.20*17.00*1.90	0.395	1.603
814	13.80*17.60*1.90	0.419	1.676
815	14.20*18.00*1.90	0.434	1.763
816	14.80*18.60*1.90	0.473	1.836
817	15.00*18.80*1.90	0.473	1.836
818	15.20*19.00*1.90	0.467	1.802
819	15.80*19.60*1.90	0.473	1.802
820	16.00*19.80*1.90	0.509	1.944
821	16.20*20.00*1.90	0.509	1.944
822	16.80*20.60*1.90	0.525	2.041
823	17.20*21.00*1.90	0.525	2.041
824	17.50*21.30*1.90	0.542	2.041
825	17.80*21.60*1.90	0.542	2.002
826	18.20*22.00*1.90	0.551	2.121
827	18.80*22.60*1.90	0.559	2.296
828	19.20*23.00*1.90	0.544	2.214
829	19.80*23.60*1.90	0.57	2.361
830	20.00*23.80*1.90	0.567	2.477
831	20.20*24.00*1.90	0.586	2.586
832	20.50*24.30*1.90	0.6	2.828
833	21.20*25.00*1.90	0.602	2.828
834	22.20*26.00*1.90	0.602	2.831
835	23.20*27.00*1.90	0.606	3.007
836	23.50*27.30*1.90	0.621	3.007
837	24.20*28.00*1.90	0.633	3.007
838	24.70*28.50*1.90	0.637	3.007
839	25.20*29.00*1.90	0.628	3.007
840	26.20*30.00*1.90	0.635	3.331
841	27.20*31.00*1.90	0.66	3.244
842	27.70*31.50*1.90	0.695	3.753
843	28.00*31.80*1.90	0.711	3.841
844	28.20*32.00*1.90	0.711	3.841
845	29.20*33.00*1.90	0.685	3.841
846	29.70*33.50*1.90	0.696	3.841
847	30.20*34.00*1.90	0.711	3.841
848	31.20*35.00*1.90	0.711	3.841
849	32.20*36.00*1.90	0.761	3.957
850	33.20*37.00*1.90	0.771	4.434
851	34.20*38.00*1.90	0.832	4.783
852	35.20*39.00*1.90	0.923	4.783
853	36.20*40.00*1.90	0.862	4.783
854	37.20*41.00*1.90	1.805	4.783



现货O-型圈 O-RING IN STOCK

序号	规格	丁腈橡胶单价RMB	氟橡胶单价RMB
NO.	SPECIFICATION	NBR PRICE	FKM PRICE
855	38.20*42.00*1.90	1.535	4.783
856	39.20*43.00*1.90	0.923	4.958
857	39.50*43.30*1.90	0.926	4.958
858	40.00*43.80*1.90	0.929	4.958
859	41.20*45.00*1.90	0.956	4.958
860	43.00*46.80*1.90	0.98	5.691
861	44.20*48.00*1.90	1.01	6.242
862	48.00*51.80*1.90	1.1	6.739
863	49.20*53.00*1.90	1.15	6.739
864	51.00*54.80*1.90	1.173	6.739
865	69.20*73.00*1.90	1.5	8.895
866	73.00*76.80*1.90	1.98	9.044
867	75.00*78.80*1.90	2.046	9.156
868	81.20*85.00*1.90	2.211	9.44
869	84.00*87.80*1.90	2.285	9.79
870	110.00*113.80*1.90	2.977	19.397
871	120.00*123.80*1.90	3.243	19.397
872	123.50*127.30*1.90	3.35	21.476
873	196.00*199.90*1.90	10.5	24.974
874	50.47*54.33*1.93	1.245	7.551
875	52.55*56.43*1.94	1.321	10.738
876	1.00*5.00*2.00	0.279	0.362
877	1.20*5.20*2.00	0.275	0.358
878	2.00*6.00*2.00	0.258	0.419
879	2.10*6.10*2.00	0.264	0.433
880	2.50*6.50*2.00	0.266	0.486
881	3.00*7.00*2.00	0.234	0.52
882	3.50*7.50*2.00	0.231	0.591
883	4.00*8.00*2.00	0.226	0.644
884	4.40*8.40*2.00	0.22	0.67
885	4.60*8.60*2.00	0.228	0.698
886	5.00*9.00*2.00	0.237	0.698
887	5.20*9.20*2.00	0.237	0.719
888	5.50*9.50*2.00	0.233	0.799
889	6.00*10.00*2.00	0.244	0.82
890	6.50*10.50*2.00	0.247	0.863
891	6.60*10.60*2.00	0.247	0.837
892	6.80*10.80*2.00	0.242	0.883
893	7.00*11.00*2.00	0.238	0.913
894	7.50*11.50*2.00	0.266	1.047
895	8.00*12.00*2.00	0.255	1.039
896	8.50*12.50*2.00	0.3	1.039
897	9.00*13.00*2.00	0.278	1.106
898	9.50*13.50*2.00	0.301	1.262
899	10.00*14.00*2.00	0.315	1.109
900	10.50*14.50*2.00	0.348	1.325
901	11.00*15.00*2.00	0.33	1.247
902	11.20*15.20*2.00	0.336	1.314
903	11.50*15.50*2.00	0.34	1.285
904	12.00*16.00*2.00	0.374	1.589
905	12.50*16.50*2.00	0.389	1.501
906	13.00*17.00*2.00	0.389	1.501
907	13.20*17.20*2.00	0.389	1.501
908	13.50*17.50*2.00	0.443	1.575
909	13.80*17.80*2.00	0.443	1.662
910	13.90*17.90*2.00	0.448	1.653
911	14.00*18.00*2.00	0.458	1.75
912	14.50*18.50*2.00	0.475	1.769
913	15.00*19.00*2.00	0.492	1.968
914	15.50*19.50*2.00	0.492	1.968
915	16.00*20.00*2.00	0.497	1.968
916	16.50*20.50*2.00	0.512	2.016
917	17.00*21.00*2.00	0.525	2.004
918	17.17*21.17*2.00	0.526	2.077
919	17.50*21.50*2.00	0.507	2.077
920	18.00*22.00*2.00	0.507	2.05
921	18.50*22.50*2.00	0.526	2.149
922	19.00*23.00*2.00	0.556	2.324
923	19.50*23.50*2.00	0.537	2.215
924	20.00*24.00*2.00	0.556	2.324
925	20.50*24.50*2.00	0.556	2.324
926	21.00*25.00*2.00	0.561	2.324

序号	规格	丁腈橡胶单价RMB	氟橡胶单价RMB
NO.	SPECIFICATION	NBR PRICE	FKM PRICE
927	21.50*25.50*2.00	0.583	2.531
928	22.00*26.00*2.00	0.583	2.531
929	23.00*27.00*2.00	0.583	2.531
930	23.50*27.50*2.00	0.605	2.656
931	24.00*28.00*2.00	0.609	2.856
932	24.50*28.50*2.00	0.644	2.953
933	25.00*29.00*2.00	0.644	3.128
934	25.50*29.50*2.00	0.669	3.099
935	26.00*30.00*2.00	0.694	3.404
936	27.00*31.00*2.00	0.709	3.55
937	27.50*31.50*2.00	0.719	3.695
938	28.00*32.00*2.00	0.77	3.841
939	28.30*32.30*2.00	0.719	3.841
940	28.50*32.50*2.00	0.77	3.841
941	29.00*33.00*2.00	0.759	3.911
942	29.50*33.50*2.00	0.79	4.12
943	30.00*34.00*2.00	0.79	4.434
944	30.50*34.50*2.00	0.79	4.085
945	31.00*35.00*2.00	0.844	4.303
946	31.50*35.50*2.00	0.82	4.12
947	32.00*36.00*2.00	0.881	4.12
948	32.50*36.50*2.00	0.881	4.12
949	33.00*37.00*2.00	0.835	4.12
950	33.50*37.50*2.00	0.82	4.132
951	34.00*38.00*2.00	0.825	4.132
952	34.50*38.50*2.00	0.828	4.132
953	35.00*39.00*2.00	0.778	4.132
954	35.50*39.50*2.00	0.812	4.132
955	36.00*40.00*2.00	0.907	4.296
956	36.50*40.50*2.00	0.919	4.102
957	37.00*41.00*2.00	0.931	4.102
958	37.50*41.50*2.00	0.943	4.102
959	38.00*42.00*2.00	0.955	4.16
960	38.50*42.50*2.00	0.966	4.16
961	39.00*43.00*2.00	0.978	4.199
962	39.50*43.50*2.00	0.99	4.248
963	40.00*44.00*2.00	1.002	4.615
964	41.00*45.00*2.00	1.026	4.615
965	41.50*45.50*2.00	1.038	4.615
966	42.00*46.00*2.00	1.05	4.615
967	43.00*47.00*2.00	1.074	4.833
968	43.50*47.50*2.00	1.086	4.833
969	44.00*48.00*2.00	1.098	5.051
970	44.50*48.50*2.00	1.11	5.051
971	45.00*49.00*2.00	1.122	5.117
972	45.50*49.50*2.00	1.134	5.117
973	46.00*50.00*2.00	1.145	5.15
974	46.50*50.50*2.00	1.157	5.15
975	47.00*51.00*2.00	1.169	5.422
976	47.50*51.50*2.00	1.299	5.025
977	48.00*52.00*2.00	1.313	5.424
978	48.40*52.40*2.00	1.313	5.424
979	49.00*53.00*2.00	1.333	5.95
980	49.50*53.50*2.00	1.414	6.035
981	50.00*54.00*2.00	1.365	6.035
982	51.00*55.00*2.00	1.391	6.035
983	52.00*56.00*2.00	1.418	6.012
984	52.50*56.50*2.00	1.431	6.035
985	53.00*57.00*2.00	1.444	6.284
986	53.50*57.50*2.00	1.462	6.284
987	54.00*58.00*2.00	1.47	6.284
988	54.50*58.50*2.00	1.548	6.895
989	55.00*59.00*2.00	1.532	6.895
990	55.50*59.50*2.00	1.792	6.895
991	56.00*60.00*2.00	1.573	7.041
992	57.00*61.00*2.00	1.573	7.332
993	58.00*62.00*2.00	1.718	7.332
994	58.50*62.50*2.00	1.733	7.332
995	59.00*63.00*2.00	1.747	7.506
996	59.50*63.50*2.00	1.761	7.332
997	60.00*64.00*2.00	1.775	7.913
998	61.00*65.00*2.00	1.804	7.332

序号	规格	丁腈橡胶单价RMB	氟橡胶单价RMB
NO.	SPECIFICATION	NBR PRICE	FKM PRICE
999	61.50*65.50*2.00	1.818	7.332
1000	62.00*66.00*2.00	1.831	8.495
1001	62.50*66.50*2.00	1.847	8.495
1002	63.00*67.00*2.00	1.861	8.495
1003	64.00*68.00*2.00	1.959	8.651
1004	64.50*68.50*2.00	2.073	8.393
1005	65.00*69.00*2.00	2.012	8.393
1006	66.00*70.00*2.00	2.158	8.882
1007	66.50*70.50*2.00	2.134	8.742
1008	67.00*71.00*2.00	2.194	9.091
1009	68.00*72.00*2.00	2.255	9.022
1010	69.00*73.00*2.00	2.134	9.022
1011	69.50*73.50*2.00	2.134	9.022
1012	70.00*74.00*2.00	2.156	9.022
1013	70.50*74.50*2.00	2.194	9.022
1014	71.00*75.00*2.00	2.315	9.022
1015	71.50*75.50*2.00	2.315	9.022
1016	72.00*76.00*2.00	2.194	9.091
1017	73.00*77.00*2.00	2.321	9.254
1018	74.00*78.00*2.00	2.437	9.254
1019	74.50*78.50*2.00	2.191	9.254
1020	75.00*79.00*2.00	2.255	9.254
1021	76.00*80.00*2.00	2.437	9.254
1022	77.00*81.00*2.00	2.352	9.999
1023	78.00*82.00*2.00	2.376	9.999
1024	79.00*83.00*2.00	2.336	9.999
1025	79.50*83.50*2.00	2.376	10.139
1026	80.00*84.00*2.00	2.355	10.139
1027	81.00*85.00*2.00	2.664	12.787
1028	82.00*86.00*2.00	2.531	12.351
1029	83.00*87.00*2.00	2.434	12.351
1030	84.00*88.00*2.00	2.512	12.351
1031	84.50*88.50*2.00	2.89	12.351
1032	85.00*89.00*2.00	2.907	12.351
1033	86.00*90.00*2.00	2.94	12.351
1034	87.00*91.00*2.00	2.973	12.874
1035	88.00*92.00*2.00	3.007	12.874
1036	89.50*93.50*2.00	3.057	12.787
1037	90.00*94.00*2.00	3.074	12.787
1038	91.00*95.00*2.00	3.107	12.787
1039	92.00*96.00*2.00	3.141	13.66
1040	93.00*97.00*2.00	3.174	13.66
1041	94.00*98.00*2.00	3.207	13.66
1042	94.50*98.50*2.00	3.685	13.66
1043	95.00*99.00*2.00	3.704	13.682
1044	96.00*100.00*2.00	3.742	14.533
1045	97.00*101.00*2.00	3.78	14.533
1046	98.00*102.00*2.00	3.818	14.533
1047	99.00*103.00*2.00	3.856	14.533
1048	99.70*103.70*2.00	3.89	14.533
1049	100.00*104.00*2.00	3.895	14.533
1050	102.00*106.00*2.00	3.929	14.533
1051	104.00*108.00*2.00	4.047	15.842
1052	104.50*108.50*2.00	4.066	15.842
1053	105.00*109.00*2.00	4.086	15.842
1054	106.00*110.00*2.00	4.124	17.69
1055	107.00*111.00*2.00	4.162	17.69
1056	109.50*113.50*2.00	4.257	18.466
1057	110.00*114.00*2.00	4.276	18.466
1058	111.50*115.50*2.00	4.334	18.854
1059	112.00*116.00*2.00	4.354	21.476
1060	113.00*117.00*2.00	4.392	23.221
1061	114.00*118.00*2.00	4.429	23.221
1062	114.50*118.50*2.00	4.448	23.221
1063	115.00*119.00*2.00	4.467	23.221
1064	116.00*120.00*2.00	4.51	24.967
1065	118.00*122.00*2.00	4.582	24.967
1066	119.50*123.50*2.00	4.639	24.967
1067	120.00*124.00*2.00	4.658	24.967
1068	124.50*128.50*2.00	4.83	24.967
1069	125.00*129.00*2.00	4.849	24.967
1070	128.00*132.00*2.00	4.964	24.967

现货O-型圈 O-RING IN STOCK

序号	规格	丁腈橡胶单价RMB	氟橡胶单价RMB
NO.	SPECIFICATION	NBR PRICE	FKM PRICE
1071	129.50*133.50*2.00	5.021	24.967
1072	130.00*134.00*2.00	5.04	24.967
1073	131.50*135.50*2.00	5.097	24.967
1074	134.50*138.50*2.00	5.212	24.967
1075	135.00*139.00*2.00	5.3	24.967
1076	139.50*143.50*2.00	5.403	24.967
1077	140.00*144.00*2.00	5.422	25.66
1078	143.00*147.00*2.00	5.536	25.66
1079	144.50*148.50*2.00	5.594	25.66
1080	145.00*149.00*2.00	5.6	26.712
1081	146.00*150.00*2.00	5.651	26.712
1082	149.00*153.00*2.00	6.486	26.712
1083	150.00*154.00*2.00	8.706	28.892
1084	160.00*164.00*2.00	9.278	28.457
1085	163.00*167.00*2.00	9.99	31.948
1086	188.00*192.00*2.00	10.882	33.306
1087	190.00*194.00*2.00	11.2	33.306
1088	200.00*204.00*2.00	12.5	33.306
1089	210.00*214.00*2.00	11.2	43.66
1090	220.00*224.00*2.00	12.2	53.666
1091	221.20*225.20*2.00	13.849	53.666
1092	226.00*230.00*2.00	14.147	63.666
1093	230.00*234.00*2.00	14.2	68.448
1094	245.00*249.00*2.00	14.5	68.448
1095	250.00*254.00*2.00	15.2	68.448
1096	260.00*264.00*2.00	16.2	71.939
1097	270.00*274.00*2.00	17.2	71.939
1098	13.46*17.62*2.08	0.481	1.542
1099	3.80*8.00*2.10	0.186	0.551
1100	7.00*11.20*2.10	0.247	0.998
1101	9.50*13.70*2.10	0.366	1.107
1102	17.50*21.70*2.10	0.501	2.077
1103	60.13*64.43*2.15	1.82	8.666
1104	117.00*121.30*2.15	5.257	16.952
1105	6.00*10.40*2.20	0.364	0.984
1106	8.00*12.40*2.20	0.388	1.007
1107	9.30*13.70*2.20	0.398	1.132
1108	10.00*14.40*2.20	0.423	1.249
1109	11.00*15.40*2.20	0.435	1.767
1110	14.00*18.40*2.20	0.561	1.767
1111	16.20*20.60*2.20	0.638	1.841
1112	16.50*20.90*2.20	0.648	1.809
1113	19.30*23.70*2.20	0.745	2.447
1114	22.00*26.40*2.20	0.844	2.847
1115	24.00*28.40*2.20	0.908	2.847
1116	36.50*40.90*2.20	1.341	4.288
1117	39.60*44.00*2.2	1.435	5.307
1118	50.70*55.10*2.20	1.833	6.459
1119	16.36*20.78*2.21	0.649	2.079
1120	92.00*96.56*2.28	3.685	14.587
1121	3.40*8.00*2.30	0.216	0.588
1122	4.00*8.60*2.30	0.365	0.68
1123	5.40*10.00*2.30	0.292	0.753
1124	7.40*12.00*2.30	0.367	1.06
1125	8.90*13.50*2.30	0.424	1.222
1126	12.90*17.50*2.30	0.576	1.776
1127	14.90*19.50*2.30	0.651	1.97
1128	47.50*52.10*2.30	1.53	6.647
1129	92.00*96.80*2.34	4.5	23.666
1130	103.40*108.10*2.35	3.99	25.666
1131	105.30*110.00*2.35	4.26	35.271
1132	46.48*51.26*2.39	1.998	7.873
1133	2.20*7.00*2.40	0.173	0.741
1134	3.20*8.00*2.40	0.173	0.853
1135	3.30*8.10*2.40	0.176	0.872
1136	3.60*8.40*2.40	0.184	0.898
1137	4.30*9.10*2.40	0.197	0.863
1138	4.60*9.40*2.40	0.2	0.89
1139	5.00*9.80*2.40	0.213	0.916
1140	5.20*10.00*2.40	0.216	0.916
1141	5.40*10.20*2.40	0.218	0.965
1142	5.60*10.40*2.40	0.222	0.971

序号	规格	丁腈橡胶单价RMB	氟橡胶单价RMB
NO.	SPECIFICATION	NBR PRICE	FKM PRICE
1143	6.00*10.80*2.40	0.241	1.08
1144	6.20*11.00*2.40	0.256	1.124
1145	6.60*11.40*2.40	0.266	1.137
1146	6.85*11.65*2.40	0.276	1.194
1147	7.00*11.80*2.40	0.287	1.256
1148	7.20*12.00*2.40	0.27	1.256
1149	7.30*12.10*2.40	0.287	1.256
1150	7.60*12.40*2.40	0.28	1.256
1151	8.20*13.00*2.40	0.325	1.383
1152	8.80*13.60*2.40	0.35	1.527
1153	9.00*13.80*2.40	0.348	1.517
1154	9.20*14.00*2.40	0.329	1.45
1155	9.40*14.20*2.40	0.364	1.535
1156	9.60*14.40*2.40	0.369	1.489
1157	9.80*14.60*2.40	0.36	1.584
1158	10.00*14.80*2.40	0.36	1.517
1159	10.20*15.00*2.40	0.364	1.6
1160	10.80*15.60*2.40	0.39	1.644
1161	11.00*15.80*2.40	0.436	1.841
1162	11.20*16.00*2.40	0.417	1.841
1163	11.60*16.40*2.40	0.425	1.833
1164	11.80*16.60*2.40	0.438	1.906
1165	12.00*16.80*2.40	0.45	1.92
1166	12.20*17.00*2.40	0.439	1.947
1167	12.30*17.10*2.40	0.448	1.947
1168	12.60*17.40*2.40	0.45	1.92
1169	12.80*17.60*2.40	0.478	2.079
1170	13.30*18.10*2.40	0.459	2.079
1171	13.60*18.40*2.40	0.477	2.007
1172	13.80*18.60*2.40	0.519	2.252
1173	14.00*18.80*2.40	0.525	2.287
1174	14.20*19.00*2.40	0.556	2.112
1175	14.80*19.60*2.40	0.564	2.273
1176	15.00*19.80*2.40	0.564	2.36
1177	15.20*20.00*2.40	0.564	2.36
1178	15.60*20.40*2.40	0.626	2.622
1179	15.80*20.60*2.40	0.626	2.564
1180	16.00*20.80*2.40	0.626	2.467
1181	16.20*21.00*2.40	0.626	2.622
1182	16.60*21.40*2.40	0.626	2.622
1183	16.80*21.60*2.40	0.643	2.719
1184	17.00*21.80*2.40	0.61	2.719
1185	17.20*22.00*2.40	0.705	2.719
1186	17.80*22.60*2.40	0.626	2.719
1187	18.00*22.80*2.40	0.633	2.719
1188	18.20*23.00*2.40	0.777	3.088
1189	18.80*23.60*2.40	0.777	3.131
1190	19.00*23.80*2.40	0.724	3.059
1191	19.20*24.00*2.40	0.705	3.059
1192	19.80*24.60*2.40	0.777	3.059
1193	20.00*24.80*2.40	0.777	3.088
1194	20.30*25.10*2.40	0.784	3.088
1195	20.60*25.40*2.40	0.866	3.404
1196	20.80*25.60*2.40	0.815	3.306
1197	21.00*25.80*2.40	0.815	3.306
1198	21.30*26.10*2.40	0.799	3.219
1199	21.60*26.40*2.40	0.833	3.415
1200	21.80*26.60*2.40	0.84	3.653
1201	22.00*26.80*2.40	0.909	3.653
1202	22.30*27.10*2.40	0.909	3.64
1203	23.00*27.80*2.40	0.909	3.653
1204	23.20*28.00*2.40	0.921	3.653
1205	23.30*28.10*2.40	0.931	3.778
1206	23.50*28.30*2.40	0.978	4.117
1207	24.00*28.80*2.40	0.931	4.117
1208	24.30*29.10*2.40	0.888	4.117
1209	24.50*29.30*2.40	0.931	4.117
1210	24.80*29.60*2.40	0.953	4.117
1211	25.20*30.00*2.40	0.953	4.117
1212	25.30*30.10*2.40	0.953	4.117
1213	25.60*30.40*2.40	0.953	4.165
1214	25.80*30.60*2.40	0.996	4.414

序号	规格	丁腈橡胶单价RMB	氟橡胶单价RMB
NO.	SPECIFICATION	NBR PRICE	FKM PRICE
1215	26.00*30.80*2.40	0.956	4.414
1216	26.50*31.30*2.40	0.942	4.414
1217	27.00*31.80*2.40	0.987	4.866
1218	27.20*32.00*2.40	0.992	4.866
1219	27.40*32.20*2.40	0.997	5.101
1220	27.80*32.60*2.40	1.017	5.101
1221	28.00*32.80*2.40	1.017	5.101
1222	28.80*33.60*2.40	1.068	5.004
1223	29.00*33.80*2.40	1.048	5.133
1224	29.20*34.00*2.40	1.049	5.133
1225	29.60*34.40*2.40	1.078	5.307
1226	30.00*34.80*2.40	1.017	5.307
1227	30.20*35.00*2.40	1.017	5.307
1228	31.00*35.80*2.40	1.018	5.307
1229	31.20*36.00*2.40	1.048	5.307
1230	31.80*36.60*2.40	1.048	5.307
1231	32.20*37.00*2.40	1.048	5.307
1232	32.60*37.40*2.40	1.048	5.307
1233	33.30*38.10*2.40	1.048	5.307
1234	34.00*38.80*2.40	1.085	5.307
1235	34.60*39.40*2.40	1.023	5.495
1236	35.20*40.00*2.40	1.044	5.495
1237	36.70*41.50*2.40	1.087	5.656
1238	37.20*42.00*2.40	1.089	5.656
1239	38.20*43.00*2.40	1.116	5.656
1240	39.20*44.00*2.40	1.14	5.656
1241	39.70*44.50*2.40	1.193	5.488
1242	40.00*44.80*2.40	1.231	5.706
1243	41.20*46.00*2.40	1.269	5.706
1244	42.00*46.80*2.40	1.231	5.706
1245	42.20*47.00*2.40	1.256	5.783
1246	43.00*47.80*2.40	1.269	5.924
1247	43.50*48.30*2.40	1.269	5.924
1248	44.00*48.80*2.40	1.276	5.924
1249	44.20*49.00*2.40	1.28	6.564
1250	44.70*49.50*2.40	1.295	6.564
1251	45.20*50.00*2.40	1.3	7.067
1252	45.60*50.40*2.40	1.32	7.067
1253	47.00*51.80*2.40	1.358	7.987
1254	47.20*52.00*2.40	1.5	7.518
1255	48.00*52.80*2.40	1.524	7.518
1256	49.70*54.50*2.40	1.576	7.518
1257	50.80*55.60*2.40	1.609	8.666
1258	51.20*56.00*2.40	1.761	9.733
1259	52.60*57.40*2.40	2.078	9.858
1260	53.60*58.40*2.40	1.847	9.858
1261	54.60*59.40*2.40	1.9	9.859
1262	55.60*60.40*2.40	1.913	9.859
1263	56.00*60.80*2.40	2.1	9.859
1264	58.60*63.40*2.40	2.155	9.666
1265	61.20*66.00*2.40	2.186	9.666
1266	62.60*67.40*2.40	2.278	9.666
1267	63.00*67.80*2.40	2.3	9.666
1268	64.60*69.40*2.40	2.395	9.659
1269	66.60*71.40*2.40	2.466	10.666
1270	67.20*72.00*2.40	2.5	11.566
1271	70.60*75.40*2.40	2.609	12.666
1272	72.00*76.80*2.40	2.8	13.455
1273	74.00*78.80*2.40	2.917	13.036
1274	75.20*80.00*2.40	3.229	14.781
1275	83.20*88.00*2.40	3.304	15.666
1276	85.20*90.00*2.40	3.612	17.666
1277	90.20*95.00*2.40	3.99	21.912
1278	95.00*99.80*2.40	4.2	23.221
1279	128.00*132.80*2.40	5.377	25.836
1280	130.00*134.80*2.40	5.46	32.817
1281	172.00*176.80*2.40	7.791	33.694
1282	48.45*53.29*2.42	1.539	10.912
1283	2.00*7.00*2.50	0.19	0.815
1284	3.00*8.00*2.50	0.193	0.927
1285	4.00*9.00*2.50	0.196	1.056
1286	4.50*9.50*2.50		

现货O-型圈 O-RING IN STOCK

序号	规格	丁腈橡胶单价RMB	氟橡胶单价RMB
NO.	SPECIFICATION	NBR PRICE	FKM PRICE
1287	5.00*10.00*2.50	0.211	1.056
1288	5.50*10.50*2.50	0.222	1.056
1289	5.70*10.70*2.50	0.231	1.083
1290	6.00*11.00*2.50	0.239	1.266
1291	6.50*11.50*2.50	0.26	1.266
1292	7.00*12.00*2.50	0.28	1.266
1293	7.30*12.30*2.50	0.287	1.266
1294	7.50*12.50*2.50	0.291	1.222
1295	7.70*12.70*2.50	0.297	1.238
1296	8.00*13.00*2.50	0.313	1.291
1297	8.50*13.50*2.50	0.334	1.38
1298	9.00*14.00*2.50	0.333	1.615
1299	9.50*14.50*2.50	0.375	1.513
1300	10.00*15.00*2.50	0.403	1.656
1301	10.50*15.50*2.50	0.412	1.793
1302	11.00*16.00*2.50	0.431	1.841
1303	11.30*16.30*2.50	0.432	1.867
1304	11.50*16.50*2.50	0.436	1.821
1305	12.00*17.00*2.50	0.422	1.821
1306	12.50*17.50*2.50	0.465	1.821
1307	12.70*17.70*2.50	0.471	2.033
1308	13.00*18.00*2.50	0.474	2.033
1309	13.50*18.50*2.50	0.478	2.058
1310	13.65*18.65*2.50	0.502	2.058
1311	13.80*18.80*2.50	0.521	2.083
1312	14.00*19.00*2.50	0.533	2.098
1313	14.50*19.50*2.50	0.556	2.104
1314	15.00*20.00*2.50	0.593	2.428
1315	15.50*20.50*2.50	0.576	2.283
1316	16.00*21.00*2.50	0.593	2.307
1317	16.50*21.50*2.50	0.593	2.368
1318	17.00*22.00*2.50	0.593	2.489
1319	17.60*22.60*2.50	0.621	2.677
1320	18.00*23.00*2.50	0.667	2.732
1321	18.50*23.50*2.50	0.674	2.797
1322	19.00*24.00*2.50	0.667	2.732
1323	19.50*24.50*2.50	0.694	3.01
1324	20.00*25.00*2.50	0.796	3.088
1325	20.50*25.50*2.50	0.784	3.088
1326	21.00*26.00*2.50	0.818	3.155
1327	21.50*26.50*2.50	0.866	3.404
1328	22.00*27.00*2.50	0.844	3.435
1329	22.50*27.50*2.50	0.888	3.529
1330	23.00*28.00*2.50	0.844	3.329
1331	23.10*28.10*2.50	0.85	3.329
1332	23.50*28.50*2.50	0.909	3.479
1333	23.80*28.80*2.50	0.911	3.496
1334	24.00*29.00*2.50	0.926	3.496
1335	25.00*30.00*2.50	0.931	3.747
1336	25.40*30.40*2.50	0.909	3.747
1337	26.00*31.00*2.50	1.064	4.19
1338	27.00*32.00*2.50	1.155	4.495
1339	27.70*32.70*2.50	1.155	4.52
1340	28.00*33.00*2.50	1.155	4.52
1341	28.60*33.60*2.50	1.155	4.52
1342	29.00*34.00*2.50	1.104	4.423
1343	29.60*34.60*2.50	1.145	4.568
1344	30.00*35.00*2.50	1.155	5.098
1345	30.80*35.80*2.50	1.189	5.077
1346	31.00*36.00*2.50	1.2	5.166
1347	32.00*37.00*2.50	1.215	5.166
1348	33.00*38.00*2.50	1.261	5.166
1349	34.00*39.00*2.50	1.268	5.166
1350	35.00*40.00*2.50	1.27	5.166
1351	36.00*41.00*2.50	1.272	5.166
1352	37.00*42.00*2.50	1.34	5.566
1353	38.00*43.00*2.50	1.323	5.581
1354	39.00*44.00*2.50	1.424	5.581
1355	40.00*45.00*2.50	1.4	5.848
1356	40.30*45.30*2.50	1.426	6.093
1357	41.00*46.00*2.50	1.439	6.415
1358	42.00*47.00*2.50	1.458	6.077

序号	规格	丁腈橡胶单价RMB	氟橡胶单价RMB
NO.	SPECIFICATION	NBR PRICE	FKM PRICE
1359	42.50*47.50*2.50	1.478	6.116
1360	43.00*48.00*2.50	1.496	6.142
1361	44.00*49.00*2.50	1.515	6.142
1362	44.50*49.50*2.50	1.526	6.142
1363	45.00*50.00*2.50	1.544	6.521
1364	46.00*51.00*2.50	1.589	6.521
1365	47.00*52.00*2.50	1.631	7.169
1366	48.00*53.00*2.50	1.717	7.282
1367	49.00*54.00*2.50	1.717	7.531
1368	50.00*55.00*2.50	1.731	7.282
1369	51.00*56.00*2.50	1.757	7.531
1370	52.00*57.00*2.50	1.836	7.531
1371	53.00*58.00*2.50	1.87	7.332
1372	54.00*59.00*2.50	1.904	8.684
1373	55.00*60.00*2.50	1.937	8.03
1374	57.00*62.00*2.50	2	8.666
1375	58.00*63.00*2.50	2.038	8.666
1376	59.00*64.00*2.50	2.59	8.786
1377	59.50*64.50*2.50	2.63	9.166
1378	60.00*65.00*2.50	2.632	9.166
1379	61.00*66.00*2.50	2.674	9.209
1380	62.00*67.00*2.50	2.716	9.368
1381	63.00*68.00*2.50	2.758	9.368
1382	64.00*69.00*2.50	2.801	9.572
1383	65.00*70.00*2.50	2.843	9.693
1384	66.00*71.00*2.50	2.885	9.693
1385	67.00*72.00*2.50	2.927	10.837
1386	68.00*73.00*2.50	2.969	11.535
1387	69.00*74.00*2.50	3.011	11.71
1388	70.00*75.00*2.50	3.053	11.71
1389	71.00*76.00*2.50	3.095	11.979
1390	72.00*77.00*2.50	3.137	12.113
1391	73.00*78.00*2.50	3.18	12.233
1392	73.50*78.50*2.50	3.022	12.233
1393	74.00*79.00*2.50	3.222	12.233
1394	75.00*80.00*2.50	3.264	12.233
1395	76.00*81.00*2.50	3.306	12.233
1396	77.00*82.00*2.50	3.348	12.233
1397	78.00*83.00*2.50	3.39	12.582
1398	79.00*84.00*2.50	3.432	12.582
1399	80.00*85.00*2.50	3.474	13.63
1400	81.00*86.00*2.50	3.516	14.313
1401	82.00*87.00*2.50	3.559	14.448
1402	83.00*88.00*2.50	3.601	14.448
1403	84.00*89.00*2.50	3.643	14.717
1404	85.00*90.00*2.50	3.685	14.717
1405	86.00*91.00*2.50	3.727	14.969
1406	87.00*92.00*2.50	3.769	15.12
1407	88.00*93.00*2.50	3.811	15.231
1408	89.00*94.00*2.50	3.853	15.231
1409	90.00*95.00*2.50	3.895	15.405
1410	92.00*97.00*2.50	3.995	16.666
1411	94.00*99.00*2.50	3.995	16.666
1412	95.00*100.00*2.50	4.106	16.89
1413	96.00*101.00*2.50	4.3	17.981
1414	97.00*102.00*2.50	4.35	18.221
1415	98.00*103.00*2.50	4.38	19.003
1416	100.00*105.00*2.50	4.4	19.166
1417	101.00*106.00*2.50	4.42	19.751
1418	102.00*107.00*2.50	4.43	19.969
1419	103.00*108.00*2.50	4.45	20.693
1420	104.00*109.00*2.50	4.485	20.967
1421	104.50*109.50*2.50	4.506	21.028
1422	106.00*111.00*2.50	4.555	21.657
1423	107.00*112.00*2.50	4.589	22.136
1424	108.00*113.00*2.50	4.602	22.53
1425	109.00*114.00*2.50	4.705	22.577
1426	110.00*115.00*2.50	4.738	22.982
1427	111.00*116.00*2.50	4.756	23.358
1428	112.00*117.00*2.50	4.777	23.672
1429	113.00*118.00*2.50	4.818	24.135
1430	114.00*119.00*2.50	4.868	24.712

序号	规格	丁腈橡胶单价RMB	氟橡胶单价RMB
NO.	SPECIFICATION	NBR PRICE	FKM PRICE
1431	115.00*120.00*2.50	4.9	25.112
1432	116.00*121.00*2.50	5.05	25.338
1433	117.00*122.00*2.50	5.12	25.636
1434	118.00*123.00*2.50	5.125	25.839
1435	119.00*124.00*2.50	5.13	26.666
1436	120.00*125.00*2.50	5.135	26.666
1437	121.00*126.00*2.50	5.14	26.666
1438	122.00*127.00*2.50	5.15	26.666
1439	123.00*128.00*2.50	5.285	26.666
1440	124.00*129.00*2.50	5.327	26.666
1441	125.00*130.00*2.50	5.329	26.666
1442	126.00*131.00*2.50	5.338	26.666
1443	127.00*132.00*2.50	5.426	27.586
1444	128.00*133.00*2.50	5.428	27.586
1445	129.00*134.00*2.50	5.515	28.568
1446	130.00*135.00*2.50	5.58	28.568
1447	131.00*136.00*2.50	5.65	28.568
1448	132.00*137.00*2.50	5.68	28.568
1449	133.00*138.00*2.50	5.7	28.568
1450	134.00*139.00*2.50	5.75	28.457
1451	135.00*140.00*2.50	5.791	28.457
1452	136.00*141.00*2.50	5.85	28.457
1453	137.00*142.00*2.50	5.95	28.457
1454	138.00*143.00*2.50	6.05	28.457
1455	139.00*144.00*2.50	6.15	28.457
1456	140.00*145.00*2.50	6.2	31.948
1457	141.00*146.00*2.50	6.25	31.948
1458	142.00*147.00*2.50	6.3	31.948
1459	143.00*148.00*2.50	6.35	32.666
1460	144.00*149.00*2.50	6.4	33.694
1461	145.00*150.00*2.50	6.45	33.694
1462	146.00*151.00*2.50	6.5	35.439
1463	147.00*152.00*2.50	6.55	35.439
1464	148.00*153.00*2.50	6.58	35.439
1465	149.00*154.00*2.50	6.6	35.439
1466	150.00*155.00*2.50	6.636	35.666
1467	158.00*163.00*2.50	7.322	35.666
1468	160.00*165.00*2.50	7.414	35.666
1469	170.00*175.00*2.50	7.87	35.666
1470	190.00*195.00*2.50	8.782	35.666
1471	193.00*198.00*2.50	9	35.439
1472	195.00*200.00*2.50	9.01	35.439
1473	210.00*215.00*2.50	9.695	39.909
1474	215.00*220.00*2.50	9.923	42.421
1475	260.00*265.00*2.50	14.74	65.566
1476	29.10*34.20*2.55	1.849	5.625
1477	3.80*9.00*2.60	0.389	1.157
1478	81.80*87.00*2.60	2.9	13.505
1479	100.80*106.00*2.60	4.2	15.853
1480	213.40*218.50*2.60	6.898	49.06
1481	1.24*6.48*2.62	0.254	0.878
1482	2.05*7.29*2.62	0.227	0.989
1483	2.85*8.09*2.62	0.225	1.098
1484	3.63*8.87*2.62	0.21	1.184
1485	4.42*9.66*2.62	0.228	1.314
1486	5.23*10.47*2.62	0.252	1.092
1487	6.02*11.26*2.62	0.364	1.132
1488	7.59*12.83*2.62	0.314	1.43
1489	9.20*14.44*2.62	0.396	1.687
1490	9.92*15.16*2.62	0.41	1.722
1491	10.77*16.01*2.62	0.515	1.72
1492	10.82*16.06*2.62	0.437	1.841
1493	11.35*16.59*2.62	0.437	1.841
1494	11.91*17.15*2.62	0.496	1.949
1495	12.37*17.61*2.62	0.481	2.112
1496	13.95*19.19*2.62	0.534	2.273
1497	15.08*20.32*2.62	0.581	2.273
1498	15.55*20.79*2.62	0.589	2.557
1499	15.80*21.04*2.62	0.586	2.622
1500	17.12*22.		

OIL SEAL FACTORY

现货O-型圈 O-RING IN STOCK

序号	规格	丁腈橡胶单价RMB	氟橡胶单价RMB
NO.	SPECIFICATION	NBR PRICE	FKM PRICE
1503	18.72*23.96*2.62	0.671	3.217
1504	20.30*25.54*2.62	0.714	3.435
1505	20.63*25.87*2.62	0.727	3.435
1506	21.90*27.14*2.62	0.714	3.404
1507	22.23*27.47*2.62	0.757	3.747
1508	22.50*27.74*2.62	0.775	3.826
1509	23.47*28.71*2.62	0.785	3.871
1510	24.60*29.84*2.62	0.855	3.942
1511	25.07*30.31*2.62	0.94	4.495
1512	25.80*31.04*2.62	0.935	4.495
1513	26.07*31.31*2.62	0.965	4.495
1514	26.65*31.89*2.62	1	4.679
1515	27.28*32.52*2.62	1.03	5.179
1516	27.69*32.93*2.62	1.06	5.133
1517	28.25*33.49*2.62	1.091	5.176
1518	29.82*35.06*2.62	1.091	5.482
1519	30.29*35.53*2.62	1.099	5.482
1520	31.42*36.66*2.62	1.053	5.566
1521	33.00*38.24*2.62	1.129	5.566
1522	33.50*38.74*2.62	1.129	5.566
1523	34.60*39.84*2.62	1.099	5.566
1524	36.17*41.41*2.62	1.197	6.066
1525	37.77*43.01*2.62	1.197	6.187
1526	39.35*44.59*2.62	1.289	6.187
1527	40.70*45.94*2.62	1.294	6.454
1528	40.94*46.18*2.62	1.361	6.535
1529	42.52*47.76*2.62	1.348	6.535
1530	44.12*49.36*2.62	1.396	6.688
1531	45.70*50.94*2.62	1.443	6.688
1532	47.30*52.54*2.62	1.491	7.032
1533	48.90*54.14*2.62	1.539	7.975
1534	50.47*55.71*2.62	1.586	8.821
1535	50.87*56.11*2.62	1.68	8.86
1536	52.07*57.31*2.62	1.715	8.848
1537	53.64*58.88*2.62	1.765	9.025
1538	55.25*60.49*2.62	1.858	9.677
1539	56.82*62.06*2.62	1.909	10.477
1540	58.42*63.66*2.62	1.96	10.477
1541	59.99*65.23*2.62	2.011	10.586
1542	61.60*66.84*2.62	2.062	10.768
1543	63.17*68.41*2.62	2.113	10.768
1544	64.77*70.01*2.62	2.164	10.051
1545	66.34*71.58*2.62	2.214	10.488
1546	67.95*73.19*2.62	2.266	10.488
1547	69.52*74.76*2.62	2.37	10.488
1548	69.96*75.20*2.62	2.4	11.199
1549	71.12*76.36*2.62	2.423	11.579
1550	72.70*77.94*2.62	2.475	11.535
1551	75.87*81.11*2.62	2.638	11.535
1552	78.42*83.66*2.62	2.73	13.66
1553	80.60*85.84*2.62	3.191	13.66
1554	82.22*87.46*2.62	2.978	13.66
1555	83.80*89.04*2.62	3.022	15.566
1556	85.00*90.24*2.62	3.713	15.842
1557	88.57*93.81*2.62	3.864	15.842
1558	93.38*98.62*2.62	3.943	16.566
1559	94.92*100.16*2.62	4.006	16.566
1560	101.27*106.51*2.62	4.267	18.566
1561	104.50*109.74*2.62	4.4	19.335
1562	106.00*111.24*2.62	4.461	19.534
1563	107.62*112.86*2.62	4.528	21.333
1564	110.00*115.24*2.62	4.626	21.647
1565	113.97*119.21*2.62	4.702	21.647
1566	120.32*125.56*2.62	4.946	26.09
1567	126.67*131.91*2.62	5.249	26.09
1568	129.70*134.94*2.62	5.249	27.836
1569	133.02*138.26*2.62	6.078	27.836
1570	139.37*144.61*2.62	6.362	27.836
1571	145.72*150.96*2.62	6.647	27.836
1572	147.00*152.24*2.62	6.708	29.566
1573	152.07*157.31*2.62	6.931	30.457
1574	158.42*163.66*2.62	7.216	33.912

序号	规格	丁腈橡胶单价RMB	氟橡胶单价RMB
NO.	SPECIFICATION	NBR PRICE	FKM PRICE
1575	164.77*170.01*2.62	8.125	33.912
1576	171.22*176.46*2.62	8.438	34.454
1577	177.47*182.71*2.62	9.011	37.185
1578	183.82*189.06*2.62	9.746	37.185
1579	190.17*195.41*2.62	10.078	37.185
1580	196.52*201.76*2.62	11.154	38.93
1581	202.87*208.11*2.62	11.509	40.566
1582	209.22*214.46*2.62	11.865	40.676
1583	215.57*220.81*2.62	12.221	45.666
1584	221.92*227.16*2.62	12.576	49.568
1585	228.27*233.51*2.62	13.794	51.329
1586	234.62*239.86*2.62	14.174	52.551
1587	240.97*246.21*2.62	14.553	52.551
1588	247.32*252.56*2.62	14.932	68.797
1589	280.00*285.24*2.62	17.565	79.586
1590	379.00*384.24*2.62	22.72	95.077
1591	384.12*389.36*2.62	23.154	95.757
1592	390.60*395.84*2.62	23.878	96.618
1593	422.50*427.74*2.62	25.29	100.858
1594	425.10*430.34*2.62	26.3	101.203
1595	450.60*455.84*2.62	28.9	104.592
1596	4.70*10.00*2.65	0.225	1.136
1597	5.70*11.00*2.65	0.247	1.305
1598	6.10*11.40*2.65	0.267	1.317
1599	6.70*12.00*2.65	0.298	1.42
1600	7.10*12.40*2.65	0.334	1.384
1601	7.50*12.80*2.65	0.334	1.471
1602	8.00*13.30*2.65	0.36	1.584
1603	8.50*13.80*2.65	0.36	1.584
1604	8.70*14.00*2.65	0.36	1.584
1605	9.00*14.30*2.65	0.395	1.68
1606	9.50*14.80*2.65	0.415	1.862
1607	9.70*15.00*2.65	0.421	2.033
1608	10.00*15.30*2.65	0.425	2.033
1609	10.60*15.90*2.65	0.436	2.033
1610	11.20*16.50*2.65	0.439	2.033
1611	11.50*16.80*2.65	0.478	2.079
1612	11.80*17.10*2.65	0.488	2.304
1613	12.00*17.30*2.65	0.495	2.304
1614	12.50*17.80*2.65	0.495	2.304
1615	13.20*18.50*2.65	0.556	2.461
1616	13.50*18.80*2.65	0.579	2.535
1617	14.00*19.30*2.65	0.571	2.549
1618	15.00*20.30*2.65	0.626	2.719
1619	16.00*21.30*2.65	0.64	2.525
1620	16.50*21.80*2.65	0.66	2.816
1621	17.00*22.30*2.65	0.705	2.95
1622	17.50*22.80*2.65	0.796	3.197
1623	18.00*23.30*2.65	0.815	3.197
1624	19.00*24.30*2.65	0.833	3.306
1625	20.00*25.30*2.65	0.879	3.479
1626	21.20*26.50*2.65	0.87	3.529
1627	22.40*27.70*2.65	0.953	3.903
1628	22.50*27.80*2.65	0.973	3.924
1629	23.50*28.80*2.65	0.993	4.027
1630	25.00*30.30*2.65	1.033	4.408
1631	25.50*30.80*2.65	1.068	5.004
1632	25.80*31.10*2.65	1.017	5.004
1633	26.50*31.80*2.65	1.068	5.586
1634	28.00*33.30*2.65	1.068	5.004
1635	28.50*33.80*2.65	1.144	5.441
1636	29.70*35.00*2.65	1.152	5.489
1637	30.00*35.30*2.65	1.144	5.586
1638	31.50*36.80*2.65	1.161	5.773
1639	32.50*37.80*2.65	1.188	5.773
1640	33.50*38.80*2.65	1.215	5.422
1641	34.00*39.30*2.65	1.228	5.487
1642	34.50*39.80*2.65	1.241	5.487
1643	35.50*40.80*2.65	1.268	5.728
1644	36.00*41.30*2.65	1.281	5.792
1645	36.50*41.80*2.65	1.295	5.856
1646	37.50*42.80*2.65	1.322	5.856

序号	规格	丁腈橡胶单价RMB	氟橡胶单价RMB
NO.	SPECIFICATION	NBR PRICE	FKM PRICE
1647	38.00*43.30*2.65	1.335	5.856
1648	38.70*44.00*2.65	1.354	5.856
1649	39.00*44.30*2.65	1.362	5.363
1650	40.00*45.30*2.65	1.388	5.815
1651	41.20*46.50*2.65	1.421	6.36
1652	41.70*47.00*2.65	1.434	6.723
1653	42.00*47.30*2.65	1.442	6.404
1654	42.50*47.80*2.65	1.455	6.251
1655	43.70*49.00*2.65	1.625	6.36
1656	45.00*50.30*2.65	1.701	6.797
1657	46.20*51.50*2.65	1.801	6.895
1658	47.50*52.80*2.65	1.939	7.531
1659	48.70*54.00*2.65	1.793	7.531
1660	50.00*55.30*2.65	1.828	8.593
1661	51.50*56.80*2.65	1.868	9.03
1662	52.20*57.50*2.65	1.887	9.431
1663	53.00*58.30*2.65	1.908	9.534
1664	53.40*58.70*2.65	1.919	9.729
1665	54.50*59.80*2.65	1.948	9.927
1666	55.25*60.55*2.65	1.968	10.03
1667	56.00*61.30*2.65	1.988	10.279
1668	58.00*63.30*2.65	2.042	10.351
1669	60.00*65.30*2.65	2.155	10.595
1670	61.50*66.80*2.65	2.125	10.833
1671	62.50*67.80*2.65	2.162	11.351
1672	62.80*68.10*2.65	2.17	11.534
1673	63.00*68.30*2.65	2.175	11.727
1674	65.00*70.30*2.65	2.229	11.823
1675	67.00*72.30*2.65	2.282	11.967
1676	68.00*73.30*2.65	2.309	12.015
1677	69.00*74.30*2.65	2.336	12.133
1678	70.00*75.30*2.65	2.434	12.215
1679	71.00*76.30*2.65	2.389	12.314
1680	72.00*77.30*2.65	2.416	12.317
1681	73.00*78.30*2.65	2.443	12.406
1682	74.00*79.30*2.65	2.579	13.28
1683	75.00*80.30*2.65	2.701	13.969
1684	77.50*82.80*2.65	2.809	14.28
1685	80.00*85.30*2.65	2.919	16.333
1686	82.00*87.30*2.65	3.022	16.939
1687	85.00*90.30*2.65	3.064	16.296
1688	90.00*95.30*2.65	3.158	17.103
1689	92.00*97.30*2.65	3.166	18.45
1690	95.00*100.30*2.65	3.188	19.587
1691	100.00*105.30*2.65	3.216	20.76
1692	101.00*106.30*2.65	3.216	20.76
1693	103.00*108.30*2.65	3.443	20.896
1694	106.00*111.30*2.65	3.549	23.647
1695	109.00*114.30*2.65	3.67	23.647
1696	114.00*119.30*2.65	3.823	23.647
1697	118.00*123.30*2.65	3.945	23.896
1698	119.00*124.30*2.65	4	24.181
1699	125.00*130.30*2.65	4.159	28.836
1700	128.00*133.30*2.65	4.251	29.181
1701	129.70*135.00*2.65	4.303	29.908
1702	132.00*137.30*2.65	4.478	30.158
1703	136.00*141.30*2.65	4.495	31.839
1704	140.00*145.30*2.65	4.617	32.581
1705	144.00*149.30*2.65	4.882	34.327
1706	145.00*150.30*2.65	4.9	35.548
1707	150.00*155.30*2.65	5.166	36.464
1708	151.00*156.30*2.65	5.2	36.364
1709	155.00*160.30*2.65	6.095	38.882
1710	158.00*163.30*2.65	6.2	40.566
1711	160.00*165.30*2.65	6.121	41.003
1712	164.00*169.30*2.65	6.243	42.566
1713	170.00*175.30*2.65	6.426	42.421
1714	185.00*190.30*2.65	7.15	42.421
171			

现货O-型圈 O-RING IN STOCK

序号	规格	丁腈橡胶单价RMB	氟橡胶单价RMB
NO.	SPECIFICATION	NBR PRICE	FKM PRICE
1719	224.00*229.30*2.65	8.02	45.912
1720	230.00*235.30*2.65	8.26	46.158
1721	234.00*239.30*2.65	8.034	50.566
1722	250.00*255.30*2.65	9.021	58.566
1723	9.00*14.40*2.70	0.405	3.572
1724	161.00*166.40*2.70	6.86	56.385
1725	15.40*20.90*2.75	0.686	4.333
1726	18.00*23.60*2.80	0.72	5.023
1727	90.00*95.80*2.90	3.115	30.284
1728	27.40*31.26*2.95	1.027	5.586
1729	3.00*9.00*3.00	0.218	1.321
1730	3.50*9.50*3.00	0.228	1.466
1731	4.00*10.00*3.00	0.248	1.399
1732	4.50*10.50*3.00	0.258	1.591
1733	5.00*11.00*3.00	0.283	1.75
1734	5.60*11.60*3.00	0.308	1.783
1735	6.00*12.00*3.00	0.318	1.783
1736	6.50*12.50*3.00	0.352	1.783
1737	6.70*12.70*3.00	0.352	1.783
1738	7.00*13.00*3.00	0.337	1.755
1739	8.00*14.00*3.00	0.395	1.769
1740	8.25*14.25*3.00	0.411	2.003
1741	9.00*15.00*3.00	0.425	1.898
1742	9.20*15.20*3.00	0.441	1.952
1743	9.50*15.50*3.00	0.507	2.165
1744	9.70*15.70*3.00	0.517	2.24
1745	10.00*16.00*3.00	0.527	2.276
1746	10.80*16.80*3.00	0.556	2.461
1747	11.00*17.00*3.00	0.54	2.322
1748	11.50*17.50*3.00	0.547	2.385
1749	12.00*18.00*3.00	0.547	2.461
1750	12.50*18.50*3.00	0.55	2.461
1751	13.00*19.00*3.00	0.609	2.622
1752	13.60*19.60*3.00	0.655	2.816
1753	14.00*20.00*3.00	0.694	3.01
1754	14.80*20.80*3.00	0.694	3.01
1755	15.00*21.00*3.00	0.711	3.01
1756	15.50*21.50*3.00	0.744	3.156
1757	16.00*22.00*3.00	0.734	3.156
1758	16.50*22.50*3.00	0.734	3.243
1759	17.00*23.00*3.00	0.744	3.301
1760	17.50*23.50*3.00	0.818	3.67
1761	18.00*24.00*3.00	0.778	3.67
1762	18.20*24.20*3.00	0.894	3.67
1763	19.00*25.00*3.00	0.856	3.786
1764	19.20*25.20*3.00	0.875	3.688
1765	20.00*26.00*3.00	0.917	3.96
1766	20.50*26.50*3.00	0.94	4.152
1767	21.00*27.00*3.00	0.932	4.152
1768	21.20*27.20*3.00	0.94	4.277
1769	22.00*28.00*3.00	0.94	4.277
1770	22.20*28.20*3.00	0.94	4.277
1771	23.00*29.00*3.00	0.966	4.277
1772	23.50*29.50*3.00	0.962	4.738
1773	24.00*30.00*3.00	1.001	4.738
1774	24.80*30.80*3.00	1.078	4.844
1775	25.00*31.00*3.00	0.981	4.844
1776	26.00*32.00*3.00	1.102	5.223
1777	26.30*32.30*3.00	1.061	5.295
1778	26.50*32.50*3.00	1.089	5.376
1779	26.60*32.60*3.00	1.107	5.47
1780	27.00*33.00*3.00	1.107	5.47
1781	28.00*34.00*3.00	1.127	5.47
1782	28.50*34.50*3.00	1.177	5.586
1783	29.00*35.00*3.00	1.177	5.796
1784	29.20*35.20*3.00	1.159	5.796
1785	30.00*36.00*3.00	1.177	6.049
1786	30.50*36.50*3.00	1.567	6.049
1787	31.00*37.00*3.00	1.602	6.049
1788	31.50*37.50*3.00	1.238	6.354
1789	32.00*38.00*3.00	1.215	6.354
1790	33.00*39.00*3.00	1.215	6.354

序号	规格	丁腈橡胶单价RMB	氟橡胶单价RMB
NO.	SPECIFICATION	NBR PRICE	FKM PRICE
1791	33.50*39.50*3.00	1.218	6.354
1792	34.00*40.00*3.00	1.229	6.354
1793	34.50*40.50*3.00	1.287	6.354
1794	35.00*41.00*3.00	1.297	6.354
1795	36.00*42.00*3.00	1.397	6.817
1796	37.00*43.00*3.00	1.328	6.817
1797	37.46*43.46*3.00	1.363	6.817
1798	38.00*44.00*3.00	1.383	6.817
1799	39.00*45.00*3.00	1.398	6.817
1800	40.00*46.00*3.00	1.444	7.015
1801	41.00*47.00*3.00	1.425	7.015
1802	42.00*48.00*3.00	1.444	7.124
1803	43.00*49.00*3.00	1.478	7.397
1804	43.68*49.68*3.00	1.545	7.397
1805	44.00*50.00*3.00	1.709	8.651
1806	44.20*50.20*3.00	1.614	8.651
1807	45.00*51.00*3.00	1.643	8.651
1808	46.00*52.00*3.00	1.653	8.142
1809	47.00*53.00*3.00	1.658	8.266
1810	48.00*54.00*3.00	1.667	8.179
1811	48.50*54.50*3.00	1.731	8.179
1812	48.70*54.70*3.00	1.737	8.279
1813	49.00*55.00*3.00	1.748	8.429
1814	50.00*56.00*3.00	1.781	8.678
1815	51.00*57.00*3.00	1.815	9.027
1816	52.00*58.00*3.00	1.848	10.274
1817	53.00*59.00*3.00	1.857	10.048
1818	53.08*59.08*3.00	1.86	10.048
1819	54.00*60.00*3.00	1.898	10.048
1820	55.00*61.00*3.00	1.949	10.048
1821	56.00*62.00*3.00	1.983	10.048
1822	57.00*63.00*3.00	2.016	10.299
1823	57.70*63.70*3.00	2.04	10.241
1824	58.00*64.00*3.00	2.05	10.241
1825	59.00*65.00*3.00	2.084	10.764
1826	59.36*65.36*3.00	2.096	11.288
1827	60.00*66.00*3.00	2.117	11.288
1828	61.00*67.00*3.00	2.151	11.986
1829	62.00*68.00*3.00	2.272	11.812
1830	63.00*69.00*3.00	2.276	11.695
1831	64.00*70.00*3.00	2.37	11.404
1832	65.00*71.00*3.00	2.8	12.582
1833	66.00*72.00*3.00	2.861	12.931
1834	67.00*73.00*3.00	3.225	12.931
1835	68.00*74.00*3.00	3.22	12.931
1836	69.00*75.00*3.00	2.982	12.931
1837	70.00*76.00*3.00	3.043	13.979
1838	71.00*77.00*3.00	2.861	13.979
1839	72.00*78.00*3.00	3.164	13.979
1840	73.00*79.00*3.00	3.103	13.979
1841	74.00*80.00*3.00	3.103	14.677
1842	75.00*81.00*3.00	3.043	14.467
1843	76.00*82.00*3.00	3.103	14.467
1844	77.00*83.00*3.00	3.189	15.026
1845	78.00*84.00*3.00	3.261	15.026
1846	79.00*85.00*3.00	3.285	16.586
1847	79.50*85.50*3.00	3.346	16.586
1848	80.00*86.00*3.00	3.422	17.151
1849	80.50*86.50*3.00	3.291	17.151
1850	81.00*87.00*3.00	3.309	17.151
1851	82.00*88.00*3.00	3.346	17.151
1852	83.00*89.00*3.00	3.346	17.151
1853	84.00*90.00*3.00	3.952	17.151
1854	85.00*91.00*3.00	3.497	17.151
1855	86.00*92.00*3.00	3.497	17.587
1856	87.00*93.00*3.00	3.649	18.46
1857	88.00*94.00*3.00	3.649	18.46
1858	89.00*95.00*3.00	3.515	18.46
1859	90.00*96.00*3.00	3.8	18.46
1860	91.00*97.00*3.00	3.741	19.46
1861	92.00*98.00*3.00	3.781	19.46
1862	92.50*98.50*3.00	3.8	19.46

序号	规格	丁腈橡胶单价RMB	氟橡胶单价RMB
NO.	SPECIFICATION	NBR PRICE	FKM PRICE
1863	93.00*99.00*3.00	3.952	20.293
1864	94.00*100.00*3.00	3.86	20.205
1865	95.00*101.00*3.00	3.9	20.205
1866	96.00*102.00*3.00	3.94	20.205
1867	97.00*103.00*3.00	3.98	20.205
1868	98.00*104.00*3.00	4.019	20.205
1869	99.00*105.00*3.00	4.406	20.205
1870	100.00*106.00*3.00	4.099	21.951
1871	101.00*107.00*3.00	4.139	22.387
1872	102.00*108.00*3.00	4.179	22.387
1873	103.00*109.00*3.00	4.558	22.387
1874	104.00*110.00*3.00	4.258	23.508
1875	105.00*111.00*3.00	4.298	23.508
1876	106.00*112.00*3.00	4.338	23.508
1877	107.00*113.00*3.00	4.369	23.508
1878	108.00*114.00*3.00	4.417	24.284
1879	109.00*115.00*3.00	4.457	24.672
1880	110.00*116.00*3.00	4.497	24.672
1881	111.00*117.00*3.00	4.512	24.967
1882	113.00*119.00*3.00	4.558	24.967
1883	114.00*120.00*3.00	4.656	24.967
1884	115.00*121.00*3.00	4.696	24.527
1885	116.00*122.00*3.00	4.712	25.836
1886	117.00*123.00*3.00	4.776	25.836
1887	118.00*124.00*3.00	4.8	25.836
1888	119.00*125.00*3.00	4.855	25.448
1889	120.00*126.00*3.00	4.9	28.163
1890	121.00*127.00*3.00	4.923	28.163
1891	122.00*128.00*3.00	5.48	28.163
1892	122.50*128.50*3.00	5.076	30.552
1893	123.00*129.00*3.00	5.076	30.552
1894	124.00*130.00*3.00	5.076	30.552
1895	125.00*131.00*3.00	5.278	30.552
1896	126.00*132.00*3.00	5.15	30.203
1897	127.00*133.00*3.00	5.2	31.948
1898	128.00*134.00*3.00	5.48	31.948
1899	129.00*135.00*3.00	5.858	31.948
1900	130.00*136.00*3.00	5.952	31.948
1901	131.00*137.00*3.00	5.694	32.996
1902	132.00*138.00*3.00	5.783	32.996
1903	133.00*139.00*3.00	5.884	32.996
1904	134.00*140.00*3.00	5.884	32.996
1905	135.00*141.00*3.00	5.979	32.996
1906	136.00*142.00*3.00	6.02	35.439
1907	137.00*143.00*3.00	6.1	35.439
1908	138.00*144.00*3.00	6.121	35.439
1909	139.00*145.00*3.00	6.591	35.439
1910	139.50*145.50*3.00	6.171	35.439
1911	140.00*146.00*3.00	6.3	35.439
1912	141.00*147.00*3.00	6.312	35.439
1913	142.00*148.00*3.00	6.894	35.439
1914	143.00*149.00*3.00	6.333	35.439
1915	144.00*150.00*3.00	6.35	35.439
1916	145.00*151.00*3.00	6.39	35.439
1917	146.00*152.00*3.00	6.43	35.439
1918	147.00*153.00*3.00	6.449	38.93
1919	148.00*154.00*3.00	6.489	38.93
1920	149.00*155.00*3.00	6.549	38.93
1921	150.00*156.00*3.00	6.589	38.93
1922	152.00*158.00*3.00	6.669	38.534
1923	153.00*159.00*3.00	6.708	38.708
1924	154.00*160.00*3.00	6.748	38.882
1925	155.00*161.00*3.00	6.788	39.367
1926	160.00*166.00*3.00	6.987	39.737
1927	162.00*168.00*3.00	7.1	40.312
1928	164.00*170.00*3.00	7.146	41.232
1929	165.00*171.00*3.00	7.186	41.548
1930	169.00*175.00*3.00	7.345	42.967
1931			

现货O-型圈 O-RING IN STOCK

序号	规格	丁腈橡胶单价RMB	氟橡胶单价RMB
NO.	SPECIFICATION	NBR PRICE	FKM PRICE
1935	182.00*188.00*3.00	7.862	44.167
1936	184.00*190.00*3.00	7.942	45.029
1937	186.00*192.00*3.00	8.2	45.039
1938	190.00*196.00*3.00	8.3	45.912
1939	200.00*206.00*3.00	8.6	48.803
1940	205.00*211.00*3.00	8.778	50.912
1941	220.00*226.00*3.00	9.375	53.094
1942	230.00*236.00*3.00	9.773	54.639
1943	232.00*238.00*3.00	9.812	55.912
1944	240.00*246.00*3.00	9.971	56.385
1945	250.00*256.00*3.00	10.069	63.897
1946	255.00*261.00*3.00	10.268	70.878
1947	270.00*276.00*3.00	10.865	78.921
1948	271.00*277.00*3.00	10.9	89.596
1949	274.00*280.00*3.00	11.024	89.393
1950	282.00*288.00*3.00	11.222	89.393
1951	285.00*291.00*3.00	11.461	96.375
1952	290.00*296.00*3.00	11.66	117.321
1953	292.00*298.00*3.00	11.9	117.321
1954	300.00*306.00*3.00	12.058	117.321
1955	331.00*337.00*3.00	13.292	127.793
1956	346.00*352.00*3.00	14.25	127.793
1957	367.00*373.00*3.00	15.72	127.793
1958	442.00*448.00*3.00	18.88	127.793
1959	2.80*9.00*3.10	0.23	1.369
1960	4.80*11.00*3.10	0.288	1.783
1961	6.80*13.00*3.10	0.35	1.945
1962	8.80*15.00*3.10	0.433	2.34
1963	10.00*16.20*3.10	0.505	2.238
1964	10.40*16.60*3.10	0.519	2.317
1965	10.80*17.00*3.10	0.559	2.563
1966	13.80*20.00*3.10	0.677	2.913
1967	14.40*20.60*3.10	0.694	3.01
1968	14.80*21.00*3.10	0.711	3.107
1969	15.80*22.00*3.10	0.78	3.387
1970	16.80*23.00*3.10	0.799	3.496
1971	17.80*24.00*3.10	0.837	3.851
1972	18.50*24.70*3.10	0.856	3.96
1973	18.80*25.00*3.10	0.837	3.96
1974	19.40*25.60*3.10	0.916	4.402
1975	20.80*27.00*3.10	0.872	4.402
1976	21.80*28.00*3.10	0.937	4.402
1977	22.50*28.70*3.10	0.937	4.526
1978	22.80*29.00*3.10	0.97	4.844
1979	23.80*30.00*3.10	0.995	4.844
1980	24.40*30.60*3.10	0.995	4.844
1981	24.80*31.00*3.10	0.995	5.295
1982	24.97*28.76*3.10	0.818	5.295
1983	25.80*32.00*3.10	1.025	5.47
1984	26.50*32.70*3.10	1.071	5.732
1985	27.40*33.60*3.10	1.046	5.732
1986	27.80*34.00*3.10	1.071	5.732
1987	28.80*35.00*3.10	1.1	6.215
1988	29.20*35.40*3.10	1.094	6.215
1989	29.40*35.60*3.10	1.121	6.215
1990	29.80*36.00*3.10	1.136	6.354
1991	30.00*36.20*3.10	1.114	6.354
1992	30.80*37.00*3.10	1.155	6.354
1993	31.80*38.00*3.10	1.186	6.354
1994	33.80*40.00*3.10	1.243	6.354
1995	34.40*40.60*3.10	1.273	6.424
1996	35.80*42.00*3.10	1.298	6.307
1997	36.80*43.00*3.10	1.264	6.236
1998	37.40*43.60*3.10	1.298	6.429
1999	37.80*44.00*3.10	1.298	6.429
2000	38.80*45.00*3.10	1.424	7.233
2001	39.40*45.60*3.10	1.538	7.888
2002	40.00*46.20*3.10	1.582	8.052
2003	40.87*47.07*3.10	1.614	8.324
2004	41.80*48.00*3.10	1.648	8.106
2005	43.80*50.00*3.10	1.661	8.106
2006	44.40*50.60*3.10	1.678	8.106

序号	规格	丁腈橡胶单价RMB	氟橡胶单价RMB
NO.	SPECIFICATION	NBR PRICE	FKM PRICE
2007	45.80*52.00*3.10	1.71	8.266
2008	46.80*53.00*3.10	1.717	8.266
2009	47.40*53.60*3.10	1.735	8.266
2010	48.80*55.00*3.10	1.845	8.778
2011	49.40*55.60*3.10	1.904	9.426
2012	53.80*60.00*3.10	1.962	9.95
2013	54.40*60.60*3.10	2.063	10.532
2014	55.80*62.00*3.10	2.164	11.113
2015	56.80*63.00*3.10	2.214	11.404
2016	57.40*63.60*3.10	2.235	11.741
2017	58.80*65.00*3.10	2.265	11.695
2018	59.40*65.60*3.10	2.366	11.695
2019	60.40*66.60*3.10	2.382	11.695
2020	61.40*67.60*3.10	2.463	11.695
2021	61.80*68.00*3.10	2.214	11.404
2022	62.40*68.60*3.10	2.164	11.113
2023	63.80*70.00*3.10	2.285	11.94
2024	64.40*70.60*3.10	2.285	11.94
2025	66.40*72.60*3.10	2.369	12.582
2026	67.40*73.60*3.10	2.645	12.582
2027	68.80*75.00*3.10	2.308	13.28
2028	69.40*75.60*3.10	2.551	14.328
2029	73.80*80.00*3.10	2.49	14.328
2030	74.40*80.60*3.10	2.793	14.677
2031	76.80*83.00*3.10	2.855	15.854
2032	78.80*85.00*3.10	2.914	16.771
2033	79.40*85.60*3.10	2.975	16.771
2034	81.80*88.00*3.10	3.022	16.771
2035	83.00*89.20*3.10	3.132	16.771
2036	83.80*90.00*3.10	3.146	17.587
2037	84.40*90.60*3.10	3.298	17.587
2038	88.80*95.00*3.10	3.373	18.966
2039	89.40*95.60*3.10	3.449	19.879
2040	93.80*100.00*3.10	3.449	19.551
2041	94.40*100.60*3.10	3.638	20.423
2042	98.80*105.00*3.10	3.724	21.296
2043	99.40*105.60*3.10	3.752	21.951
2044	103.80*110.00*3.10	3.752	21.623
2045	104.40*110.60*3.10	3.998	22.496
2046	108.80*115.00*3.10	3.976	24.439
2047	109.40*115.60*3.10	4.784	26.999
2048	111.80*118.00*3.10	4.268	28.457
2049	113.80*120.00*3.10	3.774	28.457
2050	114.40*120.60*3.10	4.683	28.457
2051	118.00*124.20*3.10	4.459	28.457
2052	118.80*125.00*3.10	4.582	28.457
2053	119.40*125.60*3.10	4.582	28.457
2054	123.80*130.00*3.10	4.582	28.457
2055	124.40*130.60*3.10	4.683	28.457
2056	128.80*135.00*3.10	4.885	28.457
2057	129.40*135.60*3.10	5.39	29.666
2058	133.80*140.00*3.10	4.986	29.666
2059	134.40*140.60*3.10	5.39	29.666
2060	138.80*145.00*3.10	5.457	29.666
2061	139.40*145.60*3.10	5.39	31.654
2062	143.80*150.00*3.10	5.429	36.308
2063	144.40*150.60*3.10	5.592	36.308
2064	147.80*154.00*3.10	5.895	36.308
2065	148.80*155.00*3.10	6.043	39.842
2066	149.40*155.60*3.10	6.061	39.953
2067	150.00*156.20*3.10	6.08	40.065
2068	153.80*160.00*3.10	6.198	40.065
2069	154.40*160.60*3.10	6.812	40.883
2070	155.00*161.20*3.10	6.833	40.995
2071	155.40*161.60*3.10	6.847	41.07
2072	158.80*165.00*3.10	6.966	41.702
2073	159.80*166.00*3.10	7.001	41.888
2074	163.80*170.00*3.10	7.14	42.632
2075	164.40*170.60*3.10	7.161	42.744
2076	168.80*175.00*3.10	7.315	42.744
2077	170.00*176.20*3.10	7.577	42.744
2078	173.80*180.00*3.10	7.49	43.586

序号	规格	丁腈橡胶单价RMB	氟橡胶单价RMB
NO.	SPECIFICATION	NBR PRICE	FKM PRICE
2079	174.30*180.50*3.10	7.507	44.586
2080	178.80*185.00*3.10	7.665	45.423
2081	180.00*186.20*3.10	7.706	45.647
2082	183.80*190.00*3.10	7.839	46.354
2083	185.00*191.20*3.10	7.881	46.577
2084	189.30*195.50*3.10	8.031	47.377
2085	193.80*200.00*3.10	8.189	48.214
2086	194.30*200.50*3.10	8.206	48.307
2087	198.80*205.00*3.10	8.363	49.144
2088	199.40*205.60*3.10	8.384	49.256
2089	203.80*210.00*3.10	8.538	50.075
2090	204.40*210.60*3.10	8.951	50.186
2091	208.80*215.00*3.10	9.113	51.148
2092	209.40*215.60*3.10	9.135	52.148
2093	213.80*220.00*3.10	9.297	53.148
2094	218.80*225.00*3.10	9.481	54.148
2095	223.80*230.00*3.10	9.888	78.921
2096	228.30*234.50*3.10	10.074	82.184
2097	233.80*240.00*3.10	10.277	82.184
2098	238.80*245.00*3.10	10.461	82.184
2099	240.00*246.20*3.10	10.505	82.184
2100	243.80*250.00*3.10	10.645	82.412
2101	248.80*255.00*3.10	10.829	86.601
2102	250.00*256.20*3.10	10.873	86.601
2103	253.80*260.00*3.10	11.013	86.601
2104	255.00*261.20*3.10	11.057	89.393
2105	259.00*265.20*3.10	11.126	92.884
2106	265.00*271.20*3.10	11.432	92.884
2107	275.00*281.20*3.10	11.794	94.866
2108	295.00*301.20*3.10	12.544	96.938
2109	313.80*320.00*3.10	13.826	100.242
2110	338.00*344.20*3.10	14.114	104.494
2111	343.00*349.20*3.10	14.298	105.373
2112	6.00*12.40*3.20	0.38	2.028
2113	80.00*86.40*3.20	4.186	22.019
2114	149.00*159.40*3.20	7.657	41.81
2115	132.5*138.94*3.22	5.88	38.894
2116	54.00*60.60*3.30	2.194	19.73
2117	88.50*95.10*3.30	4.558	24.941
2118	342.00*348.60*3.30	16.513	105.612
2119	18.60*25.34*3.37	0.95	6.358
2120	20.70*27.50*3.40	1.369	6.595
2121	23.20*30.00*3.40	1.511	7.5
2122	91.8*98.6*3.4	5.517	38.762
2123	4.00*11.00*3.50	0.46	2.118
2124	5.00*12.00*3.50	0.46	2.123
2125	6.00*13.00*3.50	0.46	2.409
2126	7.00*14.00*3.50	0.46	2.629
2127	8.00*15.00*3.50	0.516	2.672
2128	8.50*15.50*3.50	0.516	2.755
2129	9.00*16.00*3.50	0.539	2.972
2130	9.50*16.50*3.50	0.574	2.978
2131	10.00*17.00*3.50	0.588	3.057
2132	11.00*18.00*3.50	0.67	3.407
2133	12.70*19.70*3.50	0.756	3.495
2134	13.00*20.00*3.50	0.791	3.512
2135	14.00*21.00*3.50	0.807	3.786
2136	14.50*21.50*3.50	0.794	3.786
2137	15.00*22.00*3.50	0.84	3.883
2138	16.00*23.00*3.50	0.883	4.259
2139	16.70*23.70*3.50	0.955	4.39
2140	17.00*24.00*3.50	0.894	4.506
2141	18.00*25.00*3.50	0.913	4.506
2142	19.00*26.00*3.50	0.951	4.615
2143	19.70*26.70*3.50	1.038	5.274
2144	20.00*27.00*3.50	1.015	5.274



现货O-型圈 O-RING IN STOCK

序号	规格	丁腈橡胶单价RMB	氟橡胶单价RMB
NO.	SPECIFICATION	NBR PRICE	FKM PRICE
2151	23.00*30.00*3.50	1.098	5.773
2152	23.70*30.70*3.50	1.177	5.773
2153	23.90*30.90*3.50	1.181	5.524
2154	24.00*31.00*3.50	1.196	5.702
2155	24.50*31.50*3.50	1.203	6.168
2156	24.70*31.70*3.50	1.253	6.75
2157	25.00*32.00*3.50	1.212	6.532
2158	25.20*32.20*3.50	1.228	6.604
2159	25.70*32.70*3.50	1.253	6.75
2160	26.00*33.00*3.50	1.262	6.459
2161	26.70*33.70*3.50	1.272	6.343
2162	27.00*34.00*3.50	1.276	6.313
2163	27.70*34.70*3.50	1.329	6.677
2164	28.00*35.00*3.50	1.284	6.677
2165	28.70*35.70*3.50	1.304	7.041
2166	29.00*36.00*3.50	1.304	7.041
2167	29.70*36.70*3.50	1.306	7.041
2168	30.00*37.00*3.50	1.316	7.041
2169	30.70*37.70*3.50	1.321	7.041
2170	31.00*38.00*3.50	1.336	7.041
2171	31.20*38.20*3.50	1.304	7.041
2172	31.70*38.70*3.50	1.321	7.073
2173	32.00*39.00*3.50	1.367	7.073
2174	32.70*39.70*3.50	1.367	7.073
2175	33.00*40.00*3.50	1.372	7.073
2176	33.70*40.70*3.50	1.386	7.073
2177	34.00*41.00*3.50	1.434	7.374
2178	34.70*41.70*3.50	1.457	7.357
2179	35.00*42.00*3.50	1.495	7.277
2180	35.20*42.20*3.50	1.522	7.52
2181	35.70*42.70*3.50	1.559	7.942
2182	36.00*43.00*3.50	1.6	7.942
2183	36.10*43.10*3.50	1.701	8.563
2184	36.50*43.50*3.50	1.549	8.248
2185	37.00*44.00*3.50	1.569	8.369
2186	37.70*44.70*3.50	1.6	8.369
2187	38.00*45.00*3.50	1.607	8.46
2188	38.50*45.50*3.50	1.762	8.76
2189	38.70*45.70*3.50	1.701	8.563
2190	39.00*46.00*3.50	1.724	8.433
2191	39.70*46.70*3.50	1.629	8.433
2192	40.00*47.00*3.50	1.709	8.869
2193	40.80*47.80*3.50	1.743	8.651
2194	41.00*48.00*3.50	1.8	8.979
2195	41.70*48.70*3.50	1.857	9.306
2196	42.00*49.00*3.50	1.857	9.306
2197	43.00*50.00*3.50	1.838	9.306
2198	43.70*50.70*3.50	1.875	9.415
2199	44.00*51.00*3.50	1.8	9.415
2200	45.00*52.00*3.50	1.97	9.622
2201	45.70*52.70*3.50	2.057	10.261
2202	46.00*53.00*3.50	2.124	10.213
2203	47.00*54.00*3.50	2.233	10.213
2204	47.70*54.70*3.50	2.064	10.213
2205	48.00*55.00*3.50	2.107	10.025
2206	48.70*55.70*3.50	2.107	10.025
2207	49.00*56.00*3.50	2.107	10.025
2208	49.70*56.70*3.50	2.107	10.025
2209	50.00*57.00*3.50	2.194	11.022
2210	51.00*58.00*3.50	2.28	11.022
2211	52.00*59.00*3.50	2.203	11.022
2212	52.50*59.50*3.50	2.155	11.632
2213	53.00*60.00*3.50	2.177	11.632
2214	54.00*61.00*3.50	2.194	11.632
2215	55.00*62.00*3.50	2.458	12.641
2216	56.00*63.00*3.50	2.433	12.859
2217	57.00*64.00*3.50	2.582	13.344
2218	58.00*65.00*3.50	2.736	13.295
2219	59.00*66.00*3.50	2.745	13.295
2220	59.50*66.50*3.50	2.751	13.829
2221	60.00*67.00*3.50	2.766	13.829
2222	61.00*68.00*3.50	2.777	13.829

序号	规格	丁腈橡胶单价RMB	氟橡胶单价RMB
NO.	SPECIFICATION	NBR PRICE	FKM PRICE
2223	61.60*68.60*3.50	2.837	13.877
2224	62.60*69.60*3.50	2.889	13.685
2225	63.00*70.00*3.50	2.859	14.034
2226	63.50*70.50*3.50	2.859	14.034
2227	64.00*71.00*3.50	2.974	14.034
2228	64.60*71.60*3.50	3.071	14.733
2229	67.60*74.60*3.50	3.261	15.375
2230	68.00*75.00*3.50	3.346	15.724
2231	68.50*75.50*3.50	3.285	15.375
2232	69.00*76.00*3.50	3.358	16.422
2233	70.00*77.00*3.50	3.409	16.422
2234	71.00*78.00*3.50	3.346	16.422
2235	73.00*80.00*3.50	3.54	16.771
2236	74.60*81.60*3.50	3.588	17.12
2237	75.00*82.00*3.50	3.467	17.12
2238	77.00*84.00*3.50	3.781	18.023
2239	78.00*85.00*3.50	3.935	19.023
2240	79.00*86.00*3.50	3.95	20.023
2241	79.50*86.50*3.50	4.091	20.023
2242	80.00*87.00*3.50	4	20.205
2243	81.00*88.00*3.50	4.003	20.881
2244	81.60*88.60*3.50	4.243	20.881
2245	82.00*89.00*3.50	4.319	21.754
2246	83.00*90.00*3.50	4.622	21.754
2247	83.50*90.50*3.50	4.773	21.754
2248	84.00*91.00*3.50	4.319	21.754
2249	85.00*92.00*3.50	4.66	21.754
2250	87.00*94.00*3.50	4.481	21.754
2251	87.60*94.60*3.50	4.622	21.754
2252	89.60*96.60*3.50	4.78	21.843
2253	90.00*97.00*3.50	4.773	22.387
2254	91.00*98.00*3.50	4.849	22.387
2255	93.00*100.00*3.50	4.902	22.515
2256	94.00*101.00*3.50	4.996	22.515
2257	94.60*101.60*3.50	5.153	22.831
2258	97.00*104.00*3.50	5.44	22.831
2259	97.60*104.60*3.50	5.076	23.696
2260	99.00*106.00*3.50	5.176	23.696
2261	100.00*107.00*3.50	5.192	24.696
2262	101.00*108.00*3.50	5.202	24.696
2263	104.00*111.00*3.50	5.266	24.787
2264	105.00*112.00*3.50	5.531	26.314
2265	109.60*116.60*3.50	6.499	27.581
2266	111.60*118.60*3.50	7.004	29.327
2267	114.00*121.00*3.50	6.627	30.49
2268	114.70*121.70*3.50	6.735	30.49
2269	119.00*126.00*3.50	6.858	33.694
2270	120.00*127.00*3.50	7.61	33.981
2271	123.00*130.00*3.50	7.26	33.981
2272	124.60*131.60*3.50	7.307	36.308
2273	126.00*133.00*3.50	7.549	36.308
2274	129.60*136.60*3.50	7.41	36.308
2275	133.00*140.00*3.50	7.53	36.308
2276	134.50*141.50*3.50	7.587	36.308
2277	138.00*145.00*3.50	7.761	36.308
2278	139.60*146.60*3.50	7.77	39.799
2279	140.00*147.00*3.50	7.785	39.799
2280	143.00*150.00*3.50	7.951	40.676
2281	144.70*151.70*3.50	8.62	40.676
2282	148.00*155.00*3.50	8.131	42.421
2283	149.70*156.70*3.50	8.134	42.421
2284	153.00*160.00*3.50	8.252	42.625
2285	158.00*165.00*3.50	8.611	45.912
2286	163.00*170.00*3.50	8.67	45.912
2287	165.00*172.00*3.50	8.885	45.912
2288	166.00*173.00*3.50	8.902	45.912
2289	168.00*175.00*3.50	8.993	46.776
2290	170.00*177.00*3.50	9.065	46.776
2291	173.00*180.00*3.50	10.022	48.53
2292	174.00*181.00*3.50	10.033	49.53
2293	177.00*184.00*3.50	10.155	50.53
2294	178.00*185.00*3.50	10.272	51.53

序号	规格	丁腈橡胶单价RMB	氟橡胶单价RMB
NO.	SPECIFICATION	NBR PRICE	FKM PRICE
2295	180.00*187.00*3.50	10.277	52.353
2296	183.00*190.00*3.50	10.399	53.065
2297	188.00*195.00*3.50	10.522	54.712
2298	189.00*196.00*3.50	10.622	55.092
2299	193.00*200.00*3.50	11.094	56.065
2300	194.00*201.00*3.50	11.035	57.039
2301	198.00*205.00*3.50	11.211	58.902
2302	200.00*207.00*3.50	11.278	59.385
2303	204.00*211.00*3.50	11.311	62.393
2304	205.00*212.00*3.50	11.411	63.808
2305	208.00*215.00*3.50	11.511	68.337
2306	210.00*217.00*3.50	11.685	72.337
2307	213.00*220.00*3.50	12.111	75.335
2308	228.00*235.00*3.50	12.411	82.337
2309	239.00*246.00*3.50	12.811	91.252
2310	240.00*247.00*3.50	12.968	93.186
2311	246.00*253.00*3.50	13.107	95.681
2312	248.00*255.00*3.50	13.211	95.681
2313	255.00*262.00*3.50	13.513	95.681
2314	263.00*270.00*3.50	13.811	106.848
2315	267.00*274.00*3.50	14.111	106.848
2316	273.00*280.00*3.50	14.244	106.729
2317	274.00*281.00*3.50	14.285	106.729
2318	300.00*307.00*3.50	15.341	106.848
2319	320.00*327.00*3.50	16.153	117.929
2320	367.00*374.00*3.50	18.063	117.929
2321	414.00*421.00*3.50	19.972	127.793
2322	419.00*426.00*3.50	20.175	128.206
2323	472.00*479.00*3.50	22.329	138.681
2324	1.52*8.58*3.53	0.239	1.625
2325	4.34*11.40*3.53	0.352	2.145
2326	5.94*13.00*3.53	0.395	2.437
2327	6.42*13.48*3.53	0.441	2.582
2328	7.52*14.58*3.53	0.499	2.694
2329	8.42*15.48*3.53	0.516	2.963
2330	9.12*16.18*3.53	0.574	3.143
2331	10.69*17.75*3.53	0.647	3.449
2332	11.80*18.86*3.53	0.662	3.654
2333	12.29*19.35*3.53	0.744	3.859
2334	12.37*19.43*3.53	0.751	3.786
2335	13.87*20.93*3.53	0.795	4.125
2336	15.47*22.53*3.53	0.806	4.367
2337	16.00*23.06*3.53	0.818	4.881
2338	17.04*24.10*3.53	0.996	4.881
2339	18.00*25.06*3.53	1.042	5.051
2340	18.64*25.70*3.53	1.061	5.188
2341	20.22*27.28*3.53	1.083	5.539
2342	21.82*28.88*3.53	1.191	5.461
2343	23.00*30.06*3.53	1.321	6.022
2344	23.39*30.45*3.53	1.339	6.022
2345	24.99*32.05*3.53	1.549	6.495
2346	25.86*32.92*3.53	1.6	6.75
2347	26.57*33.63*3.53	1.699	6.859
2348	28.00*35.06*3.53	1.701	7.041
2349	28.17*35.23*3.53	1.765	7.332
2350	28.70*35.76*3.53	1.798	7.402
2351	29.74*36.80*3.53	1.798	7.402
2352	31.34*38.40*3.53	1.306	7.204
2353	32.92*39.98*3.53	1.434	7.762
2354	34.52*41.58*3.53	1.535	7.398
2355	36.09*43.15*3.53	1.532	8.126
2356	37.69*44.75*3.53	1.566	8.039
2357	38.00*45.06*3.53	1.835	9.339
2358	38.70*45.76*3.53	1.724	9.339
2359	39.50*46.56*3.53	1.932	9.742
2360	39.75*46.81*3.53	1.724	9.74

OIL SEAL FACTORY

现货O-型圈 O-RING IN STOCK

序号	规格	丁腈橡胶单价RMB	氟橡胶单价RMB
NO.	SPECIFICATION	NBR PRICE	FKM PRICE
2367	43.70*50.76*3.53	1.927	10.822
2368	44.04*51.10*3.53	1.983	10.822
2369	45.00*52.06*3.53	1.991	10.877
2370	45.70*52.76*3.53	2.655	11.15
2371	46.04*53.10*3.53	2.013	11.15
2372	47.22*54.28*3.53	2.28	11.343
2373	48.00*55.06*3.53	2.237	11.343
2374	49.21*56.27*3.53	2.367	11.957
2375	50.39*57.45*3.53	2.194	11.957
2376	51.00*58.06*3.53	2.323	11.957
2377	52.40*59.46*3.53	2.345	12.321
2378	53.57*60.63*3.53	2.41	12.321
2379	53.94*61.00*3.53	2.41	12.321
2380	55.60*62.66*3.53	2.61	12.568
2381	56.75*63.81*3.53	2.589	13.95
2382	57.15*64.21*3.53	2.628	13.223
2383	58.00*65.06*3.53	2.66	13.223
2384	58.74*65.80*3.53	2.61	14.677
2385	59.92*66.98*3.53	2.786	14.313
2386	60.60*67.66*3.53	2.711	14.313
2387	61.60*68.66*3.53	2.914	14.677
2388	63.09*70.15*3.53	3.225	14.415
2389	65.10*72.16*3.53	3.346	14.415
2390	66.27*73.33*3.53	3.385	14.851
2391	69.44*76.50*3.53	3.419	14.851
2392	69.85*76.91*3.53	3.467	15.942
2393	72.62*79.68*3.53	3.952	16.597
2394	74.65*81.71*3.53	3.642	17.033
2395	75.57*82.63*3.53	3.582	17.265
2396	75.80*82.86*3.53	3.588	17.033
2397	77.50*84.56*3.53	3.649	17.47
2398	78.97*86.03*3.53	4.205	18.46
2399	81.94*89.00*3.53	3.822	20.047
2400	82.14*89.20*3.53	3.918	20.205
2401	84.50*91.56*3.53	4.127	20.533
2402	85.32*92.38*3.53	3.956	20.533
2403	86.50*93.56*3.53	4.183	21.296
2404	88.00*95.06*3.53	4.183	21.078
2405	88.49*95.55*3.53	4.259	21.078
2406	90.00*97.06*3.53	4.411	21.613
2407	91.67*98.73*3.53	4.638	21.733
2408	92.50*99.56*3.53	4.411	21.733
2409	94.84*101.90*3.53	4.638	21.296
2410	95.60*102.66*3.53	4.767	21.514
2411	98.02*105.08*3.53	4.79	21.951
2412	101.20*108.26*3.53	5.244	22.823
2413	103.00*110.06*3.53	5.146	26.62
2414	104.37*111.43*3.53	5.093	26.62
2415	107.54*114.60*3.53	5.256	27.363
2416	109.09*116.15*3.53	5.518	27.363
2417	110.72*117.78*3.53	5.148	26.708
2418	113.89*120.95*3.53	5.619	27.363
2419	117.07*124.13*3.53	5.34	27.363
2420	120.25*127.31*3.53	5.417	29.327
2421	123.42*130.48*3.53	6.225	29.327
2422	126.60*133.66*3.53	6.831	29.981
2423	128.00*135.06*3.53	6.523	29.327
2424	129.77*136.83*3.53	6.925	29.981
2425	132.95*140.01*3.53	7.413	36.308
2426	136.12*143.18*3.53	7.255	36.527
2427	139.30*146.36*3.53	7.42	39.799
2428	142.47*149.53*3.53	7.585	39.799
2429	145.64*152.70*3.53	7.75	41.548
2430	148.92*155.98*3.53	7.83	45.039
2431	151.70*158.76*3.53	7.881	47.176
2432	152.00*159.06*3.53	7.896	48.176
2433	158.34*165.40*3.53	8.027	49.176
2434	164.70*171.76*3.53	8.541	50.176
2435	171.04*178.10*3.53	8.863	51.176
2436	177.40*184.46*3.53	9.613	52.894
2437	181.00*188.06*3.53	11.983	53.852
2438	183.74*190.80*3.53	12.161	54.852

序号	规格	丁腈橡胶单价RMB	氟橡胶单价RMB
NO.	SPECIFICATION	NBR PRICE	FKM PRICE
2439	190.10*197.16*3.53	12.574	55.852
2440	196.44*203.50*3.53	12.986	56.852
2441	202.80*209.86*3.53	13.399	57.852
2442	209.14*216.20*3.53	13.811	57.852
2443	215.50*222.56*3.53	14.224	61.713
2444	221.84*228.90*3.53	14.635	72.713
2445	228.20*235.26*3.53	15.049	92.884
2446	234.55*241.61*3.53	15.461	96.375
2447	240.90*247.96*3.53	20.202	97.375
2448	247.25*254.31*3.53	20.727	98.375
2449	253.60*260.66*3.53	21.252	99.375
2450	260.00*267.06*3.53	21.881	100.375
2451	266.29*273.35*3.53	22.301	101.375
2452	278.99*286.05*3.53	23.35	109.188
2453	291.69*298.75*3.53	24.4	120.812
2454	304.39*311.45*3.53	25.45	121.812
2455	329.79*336.85*3.53	27.549	122.812
2456	345.00*352.06*3.53	28.81	123.812
2457	351.00*358.06*3.53	29.3	124.812
2458	355.00*362.06*3.53	29.633	125.812
2459	380.59*387.65*3.53	36.283	126.812
2460	405.26*412.32*3.53	38.613	132.432
2461	430.66*437.72*3.53	41.013	133.432
2462	456.06*463.12*3.53	43.412	143.326
2463	6.00*13.10*3.55	0.451	2.755
2464	7.25*14.35*3.55	0.491	2.755
2465	7.50*14.60*3.55	0.505	2.755
2466	8.50*15.60*3.55	0.516	2.963
2467	9.00*16.10*3.55	0.561	3.171
2468	10.00*17.10*3.55	0.602	3.243
2469	11.00*18.10*3.55	0.677	3.567
2470	12.00*19.10*3.55	0.737	3.509
2471	12.50*19.60*3.55	0.737	3.943
2472	14.00*21.10*3.55	0.747	4.213
2473	15.00*22.10*3.55	0.862	4.368
2474	18.00*25.10*3.55	1.042	5.051
2475	19.00*26.10*3.55	1.169	5.174
2476	19.70*26.80*3.55	1.191	5.461
2477	20.00*27.10*3.55	1.191	5.274
2478	20.20*27.30*3.55	1.13	5.586
2479	21.20*28.30*3.55	1.212	5.773
2480	22.40*29.50*3.55	1.277	6.022
2481	23.00*30.10*3.55	1.339	6.153
2482	23.60*30.70*3.55	1.339	6.153
2483	24.70*31.80*3.55	1.386	6.633
2484	25.00*32.10*3.55	1.396	6.459
2485	25.50*32.60*3.55	1.406	6.859
2486	25.80*32.90*3.55	1.412	6.575
2487	26.00*33.10*3.55	1.432	6.895
2488	26.50*33.60*3.55	1.445	6.75
2489	27.00*34.10*3.55	1.457	7.041
2490	28.00*35.10*3.55	1.477	7.041
2491	29.00*36.10*3.55	1.429	7.566
2492	30.00*37.10*3.55	1.306	7.566
2493	31.50*38.60*3.55	1.336	7.566
2494	32.00*39.10*3.55	1.367	7.566
2495	32.50*39.60*3.55	1.412	7.566
2496	33.50*40.60*3.55	1.556	7.566
2497	34.00*41.10*3.55	1.517	7.732
2498	34.50*41.60*3.55	1.522	7.762
2499	35.00*42.10*3.55	1.539	7.762
2500	35.50*42.60*3.55	1.566	7.787
2501	36.09*43.19*3.55	1.566	7.787
2502	36.50*43.60*3.55	1.583	8.078
2503	37.70*44.80*3.55	1.613	8.059
2504	38.00*45.10*3.55	1.653	9.339
2505	38.50*45.60*3.55	1.532	9.339
2506	38.70*45.80*3.55	1.721	9.339
2507	39.50*46.60*3.55	1.817	9.742
2508	40.00*47.10*3.55	1.913	9.742
2509	41.00*48.10*3.55	1.761	9.824
2510	41.20*48.30*3.55	1.724	9.824

序号	规格	丁腈橡胶单价RMB	氟橡胶单价RMB
NO.	SPECIFICATION	NBR PRICE	FKM PRICE
2511	42.30*49.40*3.55	1.837	9.824
2512	42.50*49.60*3.55	1.837	9.824
2513	42.70*49.80*3.55	1.822	9.824
2514	43.70*50.80*3.55	1.553	9.824
2515	44.00*51.10*3.55	1.856	9.824
2516	45.00*52.10*3.55	2.027	9.951
2517	46.20*53.30*3.55	2.013	10.022
2518	47.30*54.40*3.55	2.184	10.598
2519	47.50*54.60*3.55	2.193	10.695
2520	48.00*55.10*3.55	2.568	10.877
2521	48.70*55.80*3.55	2.034	10.877
2522	49.21*56.31*3.55	2.138	10.971
2523	50.00*57.10*3.55	2.207	11.022
2524	51.00*58.10*3.55	2.218	11.877
2525	51.50*58.60*3.55	2.276	11.975
2526	53.00*60.10*3.55	2.366	12.022
2527	54.00*61.10*3.55	2.325	12.319
2528	54.50*61.60*3.55	2.376	12.523
2529	55.00*62.10*3.55	2.113	12.726
2530	55.50*62.60*3.55	2.164	12.831
2531	56.00*63.10*3.55	2.315	12.986
2532	56.74*63.84*3.55	2.366	13.25
2533	57.00*64.10*3.55	2.366	13.553
2534	58.00*65.10*3.55	2.315	13.986
2535	60.00*67.10*3.55	2.568	14.313
2536	60.50*67.60*3.55	2.568	14.441
2537	61.50*68.60*3.55	2.593	14.472
2538	63.00*70.10*3.55	2.812	14.659
2539	65.00*72.10*3.55	2.95	15.987
2540	67.00*74.10*3.55	3.346	16.423
2541	69.00*76.10*3.55	3.285	16.598
2542	69.44*76.54*3.55	3.467	17.618
2543	71.00*78.10*3.55	3.382	18.283
2544	71.50*78.60*3.55	3.346	18.618
2545	72.62*79.72*3.55	3.612	19.255
2546	73.00*80.10*3.55	3.54	19.533
2547	75.00*82.10*3.55	3.77	19.618
2548	77.50*84.60*3.55	3.709	20.168
2549	80.00*87.10*3.55	3.891	21.168
2550	82.50*89.60*3.55	4.679	21.533
2551	85.00*92.10*3.55	4.47	21.905
2552	87.50*94.60*3.55	4.622	22.575
2553	89.00*96.10*3.55	4.622	23.078
2554	90.00*97.10*3.55	5.099	23.347
2555	92.50*99.60*3.55	5.076	24.569
2556	93.00*100.10*3.55	5.114	24.569
2557	95.00*102.10*3.55	5.266	24.569
2558	95.80*102.90*3.55	5.312	24.569
2559	97.50*104.60*3.55	5.345	25.569
2560	100.00*107.10*3.55	5.588	26.86
2561	102.00*109.10*3.55	5.617	27.891
2562	103.00*110.10*3.55	5.682	27.187
2563	105.00*112.10*3.55	6.057	28.187
2564	106.00*113.10*3.55	6.057	29.327
2565	107.00*114.10*3.55	5.923	29.714
2566	109.00*116.10*3.55	5.949	30.714
2567	110.00*117.10*3.55	6.562	31.714
2568	112.00*119.10*3.55	6.529	32.817
2569	115.00*122.10*3.55	6.158	32.817
2570	118.00*125.10*3.55	6.259	32.662
2571	122.00*129.10*3.55	6.382	32.817
2572	125.00*132.10*3.55	6.665	33.981
2573	128.00*135.10*3.55	6.966	35.727
2574	132.00*139.10*3.55	7.37	36.727
2575	136.00*143.10*3.55	7.573	37.727
2576	140.00*147.10*3.55		

现货O-型圈 O-RING IN STOCK

序号	规格	丁腈橡胶单价RMB	氟橡胶单价RMB
NO.	SPECIFICATION	NBR PRICE	FKM PRICE
2583	165.00*172.10*3.55	9.36	47.912
2584	170.00*177.10*3.55	9.209	49.413
2585	175.00*182.10*3.55	9.346	50.276
2586	180.00*187.10*3.55	9.85	56.148
2587	185.00*192.10*3.55	11.365	58.385
2588	190.00*197.10*3.55	11.365	60.385
2589	195.00*202.10*3.55	11.335	63.385
2590	200.00*207.10*3.55	11.432	70.385
2591	210.00*217.10*3.55	11.598	75.385
2592	223.00*230.10*3.55	11.834	80.876
2593	230.00*237.10*3.55	11.989	82.624
2594	250.00*257.10*3.55	12.111	103.257
2595	262.00*269.10*3.55	12.684	106.848
2596	265.00*272.10*3.55	12.974	106.714
2597	268.00*275.10*3.55	13.114	106.714
2598	271.00*278.10*3.55	14.851	106.714
2599	278.99*286.09*3.55	14.867	107.714
2600	280.00*287.10*3.55	14.98	108.714
2601	290.00*297.10*3.55	17.881	109.714
2602	304.00*311.10*3.55	18.69	128.352
2603	307.00*314.10*3.55	19.598	128.352
2604	325.00*332.10*3.55	20.305	128.352
2605	355.00*362.10*3.55	21.123	128.793
2606	394.00*401.10*3.55	21.989	185.393
2607	456.00*463.10*3.55	23.151	186.393
2608	487.00*494.10*3.55	24.631	187.393
2609	500.00*507.10*3.55	25.89	188.393
2610	17.50*24.70*3.60	1.256	5.24
2611	18.30*25.50*3.60	1.345	5.24
2612	20.80*28.00*3.60	1.21	6.008
2613	29.30*36.50*3.60	1.926	7.576
2614	30.80*38.00*3.60	2.125	8.449
2615	67.50*74.70*3.60	3.45	62.164
2616	140.50*147.70*3.60	8	35.774
2617	146.50*153.70*3.60	8.5	43.141
2618	220.00*227.20*3.60	16.5	96.375
2619	53.50*60.80*3.65	2.555	16.736
2620	21.60*29.00*3.70	1.641	7.191
2621	24.10*31.50*3.70	1.812	7.686
2622	27.60*35.00*3.70	2.03	8.017
2623	30.30*37.70*3.70	2.127	9.148
2624	32.70*40.10*3.70	2.35	10.324
2625	33.50*40.90*3.70	2.55	10.869
2626	64.00*71.40*3.70	3.272	18.854
2627	119.60*127.00*3.70	6.956	39.386
2628	22.22*26.41*3.80	1.8	6.899
2629	32.95*37.05*3.80	2.3	10.099
2630	33.39*37.54*3.80	2.6	10.263
2631	34.50*42.10*3.80	2.62	11.275
2632	40.00*44.00*3.80	3.1	12.347
2633	13.76*21.44*3.84	1.23	5.541
2634	210.2*217.96*3.88	12.566	96.951
2635	210.80*218.60*3.90	16.055	97.951
2636	268*275.86*3.93	23.97	112.752
2637	5.00*13.00*4.00	0.465	3.311
2638	6.00*14.00*4.00	0.503	3.649
2639	6.50*14.50*4.00	0.555	3.824
2640	7.00*15.00*4.00	0.615	3.942
2641	8.00*16.00*4.00	0.643	4.168
2642	9.00*17.00*4.00	0.67	4.433
2643	10.00*18.00*4.00	0.737	4.701
2644	11.00*19.00*4.00	0.821	4.978
2645	12.00*20.00*4.00	0.879	5.299
2646	13.00*21.00*4.00	0.879	5.531
2647	13.50*21.50*4.00	0.929	5.687
2648	14.00*22.00*4.00	0.896	5.803
2649	15.00*23.00*4.00	1.008	6.092
2650	16.00*24.00*4.00	1.174	6.469
2651	17.00*25.00*4.00	1.174	6.688
2652	18.00*26.00*4.00	1.277	7.02
2653	19.00*27.00*4.00	1.321	7.269
2654	20.00*28.00*4.00	1.321	7.518

序号	规格	丁腈橡胶单价RMB	氟橡胶单价RMB
NO.	SPECIFICATION	NBR PRICE	FKM PRICE
2655	21.00*29.00*4.00	1.364	7.76
2656	22.00*30.00*4.00	1.49	8.099
2657	23.00*31.00*4.00	1.538	8.689
2658	23.50*31.50*4.00	1.552	8.689
2659	24.00*32.00*4.00	1.578	8.92
2660	25.00*33.00*4.00	1.538	8.92
2661	26.00*34.00*4.00	1.679	8.98
2662	27.00*35.00*4.00	1.659	8.204
2663	28.00*36.00*4.00	1.715	8.658
2664	29.00*37.00*4.00	1.739	8.798
2665	30.00*38.00*4.00	1.8	8.798
2666	31.00*39.00*4.00	1.793	8.556
2667	31.50*39.50*4.00	1.826	9.556
2668	32.00*40.00*4.00	1.862	10.217
2669	33.00*41.00*4.00	1.862	10.308
2670	34.00*42.00*4.00	1.845	10.308
2671	35.00*43.00*4.00	1.98	10.793
2672	36.00*44.00*4.00	1.966	10.233
2673	37.00*45.00*4.00	1.989	10.397
2674	38.00*46.00*4.00	2.038	10.669
2675	39.00*47.00*4.00	2.086	10.942
2676	39.50*47.50*4.00	2.121	10.942
2677	40.00*48.00*4.00	2.135	10.942
2678	41.00*49.00*4.00	2.183	11.16
2679	42.00*50.00*4.00	2.232	11.597
2680	43.00*51.00*4.00	2.28	12.142
2681	43.50*51.50*4.00	2.3	12.931
2682	44.00*52.00*4.00	2.497	12.931
2683	45.00*53.00*4.00	2.583	12.931
2684	46.00*54.00*4.00	2.713	13.515
2685	47.00*55.00*4.00	2.745	13.515
2686	48.00*56.00*4.00	2.66	13.515
2687	49.00*57.00*4.00	2.786	13.586
2688	50.00*58.00*4.00	2.862	14.023
2689	51.00*59.00*4.00	2.862	14.023
2690	52.00*60.00*4.00	2.812	14.023
2691	53.00*61.00*4.00	3.014	15.623
2692	54.00*62.00*4.00	3.115	15.186
2693	54.50*62.50*4.00	3.115	15.186
2694	55.00*63.00*4.00	3.089	15.768
2695	56.00*64.00*4.00	3.014	15.768
2696	57.00*65.00*4.00	3.165	15.768
2697	58.00*66.00*4.00	3.125	15.535
2698	59.00*67.00*4.00	3.165	15.768
2699	60.00*68.00*4.00	3.165	15.768
2700	61.00*69.00*4.00	3.367	16.932
2701	62.00*70.00*4.00	3.891	17.76
2702	63.00*71.00*4.00	3.77	18.517
2703	64.00*72.00*4.00	3.831	18.168
2704	65.00*73.00*4.00	3.831	19.215
2705	66.00*74.00*4.00	4.073	19.942
2706	67.00*75.00*4.00	3.952	20.942
2707	68.00*76.00*4.00	3.976	22.488
2708	69.00*77.00*4.00	4.134	22.488
2709	70.00*78.00*4.00	4.155	22.611
2710	71.00*79.00*4.00	4.255	22.611
2711	72.00*80.00*4.00	4.315	22.611
2712	73.00*81.00*4.00	4.473	22.779
2713	74.00*82.00*4.00	4.482	22.779
2714	75.00*83.00*4.00	4.501	22.779
2715	76.00*84.00*4.00	4.558	22.706
2716	77.00*85.00*4.00	4.315	22.706
2717	78.00*86.00*4.00	4.497	22.357
2718	79.00*87.00*4.00	4.925	22.823
2719	80.00*88.00*4.00	4.925	25.005
2720	81.00*89.00*4.00	5.228	24.569
2721	82.00*90.00*4.00	5.076	24.569
2722	83.00*91.00*4.00	4.849	24.569
2723	84.00*92.00*4.00	5.076	24.569
2724	85.00*93.00*4.00	5.228	24.569
2725	86.00*94.00*4.00	5.228	24.569
2726	87.00*95.00*4.00	5.531	24.102

序号	规格	丁腈橡胶单价RMB	氟橡胶单价RMB
NO.	SPECIFICATION	NBR PRICE	FKM PRICE
2727	88.00*96.00*4.00	5.548	25.102
2728	89.00*97.00*4.00	5.552	26.314
2729	90.00*98.00*4.00	5.682	27.187
2730	91.00*99.00*4.00	5.682	27.187
2731	92.00*100.00*4.00	5.682	27.187
2732	93.00*101.00*4.00	5.682	27.187
2733	94.00*102.00*4.00	5.607	28.187
2734	95.00*103.00*4.00	5.929	28.605
2735	96.00*104.00*4.00	5.758	28.605
2736	97.00*105.00*4.00	5.985	28.933
2737	98.00*106.00*4.00	5.834	28.933
2738	99.00*107.00*4.00	5.758	28.933
2739	100.00*108.00*4.00	6.175	29.933
2740	102.00*110.00*4.00	6.288	30.933
2741	104.00*112.00*4.00	6.44	31.551
2742	105.00*113.00*4.00	6.966	32.551
2743	107.00*115.00*4.00	6.653	33.551
2744	108.00*116.00*4.00	6.461	34.551
2745	109.00*117.00*4.00	6.35	35.551
2746	110.00*118.00*4.00	6.562	36.551
2747	110.60*130.00*4.00	6.822	37.551
2748	112.00*120.00*4.00	7.067	38.551
2749	113.00*121.00*4.00	7.067	39.551
2750	114.00*122.00*4.00	6.745	40.551
2751	114.60*122.60*4.00	6.865	41.551
2752	117.00*125.00*4.00	6.966	42.551
2753	118.00*126.00*4.00	7.168	42.551
2754	120.00*128.00*4.00	7.305	42.551
2755	122.00*130.00*4.00	7.529	42.551
2756	125.00*133.00*4.00	7.711	42.551
2757	127.00*135.00*4.00	8.032	42.421
2758	128.00*136.00*4.00	8.312	42.421
2759	130.00*138.00*4.00	8.722	42.421
2760	132.00*140.00*4.00	8.219	42.708
2761	134.00*142.00*4.00	8.303	42.708
2762	135.00*143.00*4.00	8.37	43.119
2763	136.00*144.00*4.00	8.426	44.119
2764	138.00*146.00*4.00	8.536	45.119
2765	140.00*148.00*4.00	8.632	46.119
2766	142.00*150.00*4.00	8.736	47.119
2767	144.00*152.00*4.00	8.828	48.119
2768	146.00*154.00*4.00	8.942	49.119
2769	148.00*156.00*4.00	9.045	49.119
2770	150.00*158.00*4.00	9.149	49.403
2771	152.00*160.00*4.00	9.302	49.403
2772	155.00*163.00*4.00	9.407	50.403
2773	157.00*165.00*4.00	9.6	51.403
2774	160.00*168.00*4.00	10.15	51.148
2775	162.00*170.00*4.00	10.881	52.894
2776	165.00*173.00*4.00	11.223	52.894
2777	167.00*175.00*4.00	11.4	53.894
2778	170.00*178.00*4.00	11.665	54.894
2779	175.00*183.00*4.00	11.907	55.894
2780	180.00*188.00*4.00	12.007	56.894
2781	185.00*193.00*4.00	12.508	57.894
2782	187.00*195.00*4.00	12.9	61.341
2783	190.00*198.00*4.00	12.999	63.367
2784	192.00*200.00*4.00	13.396	63.367
2785	197.00*205.00*4.00	13.99	63.367
2786	200.00*208.00*4.00	14.121	64.367
2787	202.00*210.00*4.00	14.21	65.367
2788	207.00*215.00*4.00	14.502	66.367
2789	212.00*220.00*4.00	14.889	67.367
2790	217.00*225.00*4.00	15.989	68.367
2791	220.00*228.00*4.00	16.49	69.367
279			

现货O-型圈 O-RING IN STOCK

序号 NO.	规格 SPECIFICATION	丁腈橡胶单价RMB NBR PRICE	氟橡胶单价RMB FKM PRICE
2799	253.00*261.00*4.00	20.6	106.895
2800	256.00*264.00*4.00	20.8	112.161
2801	260.00*268.00*4.00	20.99	113.83
2802	265.00*273.00*4.00	21.569	114.83
2803	270.00*278.00*4.00	21.97	115.83
2804	275.00*283.00*4.00	22.371	116.83
2805	277.00*285.00*4.00	22.53	117.83
2806	280.00*288.00*4.00	22.772	118.83
2807	285.00*293.00*4.00	23.173	119.83
2808	290.00*298.00*4.00	23.4	120.83
2809	292.00*300.00*4.00	23.8	121.83
2810	294.00*302.00*4.00	23.895	122.83
2811	301.50*309.50*4.00	27.995	125.83
2812	310.00*318.00*4.00	28.774	128.995
2813	320.00*328.00*4.00	29.691	130.081
2814	325.00*333.00*4.00	32.99	132.081
2815	330.00*338.00*4.00	33.1	127.081
2816	350.00*358.00*4.00	33.3	128.081
2817	360.00*368.00*4.00	33.356	129.081
2818	370.00*378.00*4.00	34.273	130.081
2819	375.00*383.00*4.00	34.99	131.081
2820	380.00*388.00*4.00	35.189	132.081
2821	390.00*398.00*4.00	36.105	133.081
2822	400.00*408.00*4.00	37.022	138.266
2823	440.00*448.00*4.00	40.687	148.739
2824	470.00*478.00*4.00	43.436	155.064
2825	530.00*538.00*4.00	48.935	169.004
2826	605.00*613.00*4.00	55.808	186.429
2827	29.10*37.30*4.10	1.85	12.395
2828	195.00*203.20*4.10	19.169	89.937
2829	62.60*71.00*4.20	4.05	22.384
2830	104.00*112.40*4.20	7.59	38.93
2831	246.30*254.70*4.20	19.145	106.835
2832	38.00*46.60*4.30	2.555	12.736
2833	48.00*56.60*4.30	3.22	17.384
2834	560.00*568.60*4.30	59.759	191.018
2835	117.00*125.80*4.40	7.426	44.167
2836	6.00*15.00*4.50	1.045	5.132
2837	16.00*25.00*4.50	1.329	7.771
2838	17.00*26.00*4.50	1.921	8.12
2839	20.00*29.00*4.50	1.588	8.12
2840	21.00*30.00*4.50	1.75	8.64
2841	24.00*33.00*4.50	1.869	9.532
2842	24.50*33.50*4.50	1.88	9.688
2843	25.00*34.00*4.50	1.912	9.688
2844	27.00*36.00*4.50	1.99	10.92
2845	28.00*37.00*4.50	2.106	10.92
2846	29.00*38.00*4.50	2.23	11.96
2847	29.50*38.50*4.50	2.283	11.823
2848	30.00*39.00*4.50	2.336	11.823
2849	31.00*40.00*4.50	2.412	12.233
2850	33.00*42.00*4.50	2.43	12.233
2851	34.00*43.00*4.50	2.667	12.931
2852	35.00*44.00*4.50	2.51	12.248
2853	35.80*44.80*4.50	2.59	12.767
2854	36.00*45.00*4.50	2.861	13.63
2855	37.00*46.00*4.50	3.152	14.419
2856	38.00*47.00*4.50	2.755	14.419
2857	39.00*48.00*4.50	3.222	14.07
2858	40.00*49.00*4.50	3.273	14.419
2859	41.00*50.00*4.50	3.239	14.969
2860	42.00*51.00*4.50	3.542	14.969
2861	43.00*52.00*4.50	3.634	14.942
2862	44.00*53.00*4.50	3.694	16.103
2863	46.00*55.00*4.50	3.32	16.278
2864	49.00*58.00*4.50	3.467	16.641
2865	50.00*59.00*4.50	3.532	17.641
2866	51.00*60.00*4.50	4.647	18.641
2867	52.00*61.00*4.50	3.65	18.896
2868	53.00*62.00*4.50	4.167	19.333
2869	54.00*63.00*4.50	3.792	19.333
2870	55.00*64.00*4.50	3.99	19.757

序号 NO.	规格 SPECIFICATION	丁腈橡胶单价RMB NBR PRICE	氟橡胶单价RMB FKM PRICE
2871	56.00*65.00*4.50	4.053	20.757
2872	57.00*66.00*4.50	4.12	20.481
2873	59.00*68.00*4.50	4.15	22.577
2874	60.00*69.00*4.50	4.18	22.577
2875	61.00*70.00*4.50	4.37	22.577
2876	62.00*71.00*4.50	4.35	23.577
2877	63.00*72.00*4.50	4.41	24.284
2878	64.00*73.00*4.50	4.45	24.284
2879	65.00*74.00*4.50	4.55	24.284
2880	66.00*75.00*4.50	4.6	24.284
2881	66.50*75.50*4.50	4.602	24.284
2882	70.00*79.00*4.50	4.828	25.284
2883	71.00*80.00*4.50	5.151	26.284
2884	73.00*82.00*4.50	5.21	26.284
2885	74.00*83.00*4.50	5.31	26.999
2886	75.00*84.00*4.50	5.41	26.751
2887	76.00*85.00*4.50	5.51	27.751
2888	79.00*88.00*4.50	5.66	28.163
2889	80.00*89.00*4.50	5.765	28.163
2890	81.00*90.00*4.50	5.96	29.394
2891	82.00*91.00*4.50	6.16	30.102
2892	83.00*92.00*4.50	6.36	31.102
2893	85.00*94.00*4.50	6.5	33.517
2894	88.00*97.00*4.50	6.762	33.517
2895	90.00*99.00*4.50	8.129	34.517
2896	92.00*101.00*4.50	6.78	35.517
2897	95.00*104.00*4.50	6.788	35.517
2898	98.00*107.00*4.50	7.408	35.263
2899	99.00*108.00*4.50	7.408	35.263
2900	100.00*109.00*4.50	7.129	35.263
2901	100.50*109.50*4.50	7.32	35.263
2902	101.00*110.00*4.50	7.42	36.263
2903	105.00*114.00*4.50	7.59	36.31
2904	107.00*116.00*4.50	7.607	36.308
2905	108.00*117.00*4.50	7.675	37.308
2906	109.00*118.00*4.50	7.79	38.308
2907	110.00*119.00*4.50	7.89	39.308
2908	112.00*121.00*4.50	7.948	39.799
2909	115.00*124.00*4.50	8.153	39.799
2910	118.00*127.00*4.50	8.55	40.799
2911	123.00*132.00*4.50	8.698	41.799
2912	125.00*134.00*4.50	8.83	42.799
2913	131.00*140.00*4.50	8.99	43.799
2914	133.00*142.00*4.50	9.381	44.799
2915	137.00*146.00*4.50	11.014	45.799
2916	139.00*148.00*4.50	11.014	46.799
2917	140.00*149.00*4.50	11.091	46.781
2918	141.00*150.00*4.50	11.153	50.272
2919	145.00*154.00*4.50	11.474	51.272
2920	155.00*164.00*4.50	12.11	59.225
2921	160.00*169.00*4.50	12.626	62.668
2922	165.00*174.00*4.50	13.5	63.668
2923	176.00*185.00*4.50	13.99	63.367
2924	180.00*189.00*4.50	14.161	64.367
2925	185.00*194.00*4.50	14.5	65.367
2926	190.00*199.00*4.50	15.5	66.857
2927	200.00*209.00*4.50	16.5	66.857
2928	205.00*214.00*4.50	17.866	70.348
2929	220.00*229.00*4.50	19.145	120.812
2930	225.00*234.00*4.50	21.529	138.266
2931	236.00*245.00*4.50	22.99	138.266
2932	250.00*259.00*4.50	23.874	138.266
2933	154.50*163.60*4.55	15.253	56.385
2934	12.80*22.00*4.60	1.085	7.073
2935	18.80*28.00*4.60	1.46	9.415
2936	19.50*28.70*4.60	1.65	10.103
2937	22.80*32.00*4.60	1.709	10.225
2938	24.80*34.00*4.60	1.834	10.902
2939	25.80*35.00*4.60	1.896	11.433
2940	26.80*36.00*4.60	1.959	11.585
2941	30.80*40.00*4.60	2.208	12.658
2942	32.80*42.00*4.60	2.333	13.217

序号 NO.	规格 SPECIFICATION	丁腈橡胶单价RMB NBR PRICE	氟橡胶单价RMB FKM PRICE
2943	35.80*45.00*4.60	2.52	14.002
2944	37.00*46.20*4.60	2.99	15.864
2945	38.80*48.00*4.60	3.094	15.415
2946	40.80*50.00*4.60	3.237	15.96
2947	43.80*53.00*4.60	3.45	17.513
2948	46.80*56.00*4.60	3.664	18.253
2949	47.00*56.20*4.60	3.828	18.253
2950	50.80*60.00*4.60	3.949	19.647
2951	55.00*64.20*4.60	4.249	20.907
2952	62.50*71.70*4.60	5.1	24.821
2953	68.50*77.70*4.60	5.6	28.939
2954	72.50*81.70*4.60	5.9	28.628
2955	78.50*87.70*4.60	6.9	33.517
2956	110.00*119.20*4.60	7.92	41.739
2957	112.00*121.20*4.60	8.2	42.739
2958	115.00*124.20*4.60	8.4	43.739
2959	120.00*129.20*4.60	8.6	44.739
2960	122.00*131.20*4.60	8.99	45.739
2961	127.50*136.70*4.60	9.2	46.781
2962	137.50*146.70*4.60	10.9	52.894
2963	142.50*151.70*4.60	11.5	91.139
2964	147.50*156.70*4.60	11.9	92.884
2965	157.00*166.20*4.60	12.6	93.884
2966	162.00*171.20*4.60	12.9	94.884
2967	167.00*176.20*4.60	13.8	95.884
2968	182.00*191.20*4.60	14.6	101.961
2969	187.00*196.20*4.60	15.5	102.961
2970	196.50*205.70*4.60	16.5	110.339
2971	201.50*210.70*4.60	16.9	110.339
2972	211.50*220.70*4.60	19.5	111.339
2973	216.00*225.20*4.60	19.7	112.339
2974	221.00*230.20*4.60	19.9	113.339
2975	226.00*235.20*4.60	22.5	114.339
2976	231.00*240.20*4.60	22.98	115.339
2977	241.00*250.20*4.60	24.2	116.339
2978	245.00*254.20*4.60	25.5	117.339
2979	537.00*546.20*4.60	38.61	193.187
2980	121.30*130.70*4.70	9.168	47.781
2981	30.18*39.68*4.75	2.655	13.289
2982	122.00*131.50*4.75	9.429	44.454
2983	5.00*15.00*5.00	0.719	5.518
2984	6.00*16.00*5.00	0.79	5.877
2985	7.00*17.00*5.00	0.813	6.245
2986	8.00*18.00*5.00	0.893	6.609
2987	9.00*19.00*5.00	0.92	7.073
2988	10.00*20.00*5.00	0.994	7.287
2989	11.00*21.00*5.00	1.213	7.627
2990	12.00*22.00*5.00	1.117	8.08
2991	13.00*23.00*5.00	1.201	8.469
2992	14.00*24.00*5.00	1.248	8.818
2993	15.00*25.00*5.00	1.314	9.167
2994	16.00*26.00*5.00	1.38	9.516
2995	17.00*27.00*5.00	1.752	10.066
2996	18.00*28.00*5.00	1.766	10.405
2997	19.00*29.00*5.00	1.878	10.732
2998	20.00*30.00*5.00	1.716	10.913
2999	20.68*30.68*5.00	1.787	11.194
3000	21.00*31.00*5.00	1.94	11.472
3001	22.00*32.00*5.00	1.774	11.811
3002	23.00*33.00*5.00	1.876	12.197
3003	24.00*34.00*5.00	1.905	12.49
3004	25.00*35.00*5.00	2.066	12.906
3005	26.00*36.00*5.00	2.037	13.233
3006	27.00*37.00*5.00	2.179	13.615
3007	28.00*38.00*5.00	2.285	13.997
3008	29.00*39.00*5.00	2.234	14.438
3009	30.00*40.00*5.0		

现货O-型圈 O-RING IN STOCK

序号	规格	丁腈橡胶单价RMB	氟橡胶单价RMB
NO.	SPECIFICATION	NBR PRICE	FKM PRICE
3015	36.00*46.00*5.00	2.694	16.779
3016	37.00*47.00*5.00	2.759	17.051
3017	38.00*48.00*5.00	2.825	17.324
3018	39.00*49.00*5.00	2.958	17.929
3019	40.00*50.00*5.00	2.956	18.142
3020	41.00*51.00*5.00	3.022	18.477
3021	42.00*52.00*5.00	3.088	18.864
3022	43.00*53.00*5.00	3.153	19.3
3023	44.00*54.00*5.00	3.645	19.866
3024	45.00*55.00*5.00	3.433	20.248
3025	46.00*56.00*5.00	3.351	20.58
3026	47.00*57.00*5.00	3.416	20.82
3027	47.40*57.40*5.00	3.442	20.996
3028	48.00*58.00*5.00	3.58	20.996
3029	49.00*59.00*5.00	3.613	23.041
3030	50.00*60.00*5.00	3.772	21.586
3031	51.00*61.00*5.00	3.679	22.556
3032	52.00*62.00*5.00	3.845	22.556
3033	53.00*63.00*5.00	3.974	22.556
3034	54.00*64.00*5.00	3.974	23.526
3035	55.00*65.00*5.00	4.075	23.526
3036	56.00*66.00*5.00	4.077	24.495
3037	57.00*67.00*5.00	4.131	24.689
3038	58.00*68.00*5.00	4.139	24.495
3039	59.00*69.00*5.00	4.205	24.495
3040	60.00*70.00*5.00	4.378	25.465
3041	61.00*71.00*5.00	4.429	26.465
3042	62.00*72.00*5.00	4.58	26.435
3043	63.00*73.00*5.00	4.908	27.435
3044	64.00*74.00*5.00	5.053	27.457
3045	65.00*75.00*5.00	5.165	27.457
3046	66.00*76.00*5.00	5.664	28.4
3047	67.00*77.00*5.00	5.73	28.57
3048	68.00*78.00*5.00	5.796	28.47
3049	69.00*79.00*5.00	6.012	28.457
3050	70.00*80.00*5.00	6.027	28.457
3051	71.00*81.00*5.00	6.059	29.688
3052	72.00*82.00*5.00	6.256	30.386
3053	73.00*83.00*5.00	6.354	30.386
3054	74.00*84.00*5.00	6.42	31.084
3055	75.00*85.00*5.00	6.486	31.084
3056	76.00*86.00*5.00	6.551	32.015
3057	77.00*87.00*5.00	6.617	32.015
3058	78.00*88.00*5.00	6.683	32.48
3059	79.00*89.00*5.00	6.748	32.899
3060	80.00*90.00*5.00	6.668	32.899
3061	81.00*91.00*5.00	6.592	32.423
3062	82.00*92.00*5.00	7.691	33.423
3063	83.00*93.00*5.00	6.895	34.169
3064	84.00*94.00*5.00	6.289	35.478
3065	85.00*95.00*5.00	7.199	35.914
3066	86.00*96.00*5.00	6.592	35.042
3067	87.00*97.00*5.00	7.805	36.042
3068	88.00*98.00*5.00	6.895	37.66
3069	89.00*99.00*5.00	9.017	37.66
3070	90.00*100.00*5.00	7.395	37.66
3071	91.00*101.00*5.00	8.07	38.66
3072	92.00*102.00*5.00	7.199	38.66
3073	93.00*103.00*5.00	7.438	38.198
3074	94.00*104.00*5.00	7.504	39.106
3075	95.00*105.00*5.00	7.653	39.106
3076	96.00*106.00*5.00	6.635	39.842
3077	97.00*107.00*5.00	7.805	39.405
3078	98.00*108.00*5.00	7.502	39.405
3079	99.00*109.00*5.00	6.832	40.933
3080	100.00*110.00*5.00	7.683	41.933
3081	103.00*113.00*5.00	8.108	42.933
3082	105.00*115.00*5.00	8.227	43.933
3083	106.00*116.00*5.00	8.411	45.036
3084	110.00*120.00*5.00	8.714	46.036
3085	112.00*122.00*5.00	8.68	46.036
3086	115.00*125.00*5.00	8.289	46.036

序号	规格	丁腈橡胶单价RMB	氟橡胶单价RMB
NO.	SPECIFICATION	NBR PRICE	FKM PRICE
3087	120.00*130.00*5.00	8.411	46.781
3088	123.00*133.00*5.00	8.714	47.781
3089	124.00*134.00*5.00	8.714	48.781
3090	125.00*135.00*5.00	8.714	49.781
3091	130.00*140.00*5.00	9.017	52.017
3092	135.00*145.00*5.00	9.197	53.763
3093	138.00*148.00*5.00	9.395	54.763
3094	140.00*150.00*5.00	10.228	55.763
3095	143.00*153.00*5.00	9.926	56.763
3096	145.00*155.00*5.00	9.926	57.763
3097	150.00*160.00*5.00	10.183	63.367
3098	155.00*165.00*5.00	11.972	68.603
3099	160.00*170.00*5.00	11.76	72.094
3100	165.00*175.00*5.00	12.972	73.094
3101	170.00*180.00*5.00	13.79	73.839
3102	175.00*185.00*5.00	13.089	74.839
3103	180.00*190.00*5.00	13.184	75.839
3104	190.00*200.00*5.00	13.487	76.839
3105	195.00*205.00*5.00	13.699	77.839
3106	200.00*210.00*5.00	14.892	84.312
3107	205.00*215.00*5.00	15.305	85.312
3108	210.00*220.00*5.00	15.775	87.803
3109	215.00*225.00*5.00	16.078	89.548
3110	220.00*230.00*5.00	16.8	123.83
3111	225.00*235.00*5.00	16.808	127.321
3112	230.00*240.00*5.00	17.414	130.812
3113	235.00*245.00*5.00	17.967	135.284
3114	240.00*250.00*5.00	18.56	136.793
3115	245.00*255.00*5.00	18.888	137.793
3116	250.00*260.00*5.00	20.217	138.793
3117	253.00*263.00*5.00	20.232	139.284
3118	255.00*265.00*5.00	20.232	140.284
3119	260.00*270.00*5.00	21.445	140.848
3120	265.00*275.00*5.00	21.938	140.935
3121	270.00*280.00*5.00	21.445	141.143
3122	275.00*285.00*5.00	24.595	143.638
3123	280.00*290.00*5.00	22.051	144.638
3124	285.00*295.00*5.00	22.051	145.638
3125	290.00*300.00*5.00	23.08	148.739
3126	295.00*305.00*5.00	23.409	147.349
3127	300.00*310.00*5.00	24.037	149.043
3128	305.00*315.00*5.00	24.466	150.833
3129	307.00*317.00*5.00	24.597	155.721
3130	310.00*320.00*5.00	24.794	156.721
3131	315.00*325.00*5.00	25.123	159.212
3132	320.00*330.00*5.00	25.451	160.212
3133	325.00*335.00*5.00	26.78	169.212
3134	330.00*340.00*5.00	27.108	175.157
3135	345.00*355.00*5.00	28.742	179.833
3136	375.00*385.00*5.00	31.206	180.157
3137	395.00*405.00*5.00	32.848	181.157
3138	400.00*410.00*5.00	33.259	187.139
3139	450.00*460.00*5.00	37.365	204.593
3140	470.00*480.00*5.00	39.007	209.223
3141	480.00*490.00*5.00	39.828	212.664
3142	520.00*530.00*5.00	43.113	226.432
3143	580.00*590.00*5.00	48.04	247.083
3144	15.00*25.60*5.30	1.6	10.066
3145	16.00*26.60*5.30	1.685	10.308
3146	17.50*28.10*5.30	1.845	11.099
3147	18.00*28.60*5.30	1.855	11.324
3148	19.00*29.60*5.30	1.876	11.488
3149	25.00*35.60*5.30	2.861	13.779
3150	28.17*38.77*5.30	2.36	15.124
3151	29.00*39.60*5.30	2.525	15.427
3152	33.00*43.60*5.30	2.299	16.417
3153	36.50*47.10*5.30	3.007	17.76
3154	38.70*49.30*5.30	3.159	18.76
3155	39.30*49.90*5.30	3.172	18.797
3156	40.00*50.60*5.30	3.18	19.015
3157	41.20*51.80*5.30	3.183	19.55
3158	42.00*52.60*5.30	3.443	19.861

序号	规格	丁腈橡胶单价RMB	氟橡胶单价RMB
NO.	SPECIFICATION	NBR PRICE	FKM PRICE
3159	42.50*53.10*5.30	3.356	20.048
3160	43.50*54.10*5.30	3.493	20.663
3161	43.70*54.30*5.30	3.567	20.485
3162	45.00*55.60*5.30	3.602	21.245
3163	46.20*56.80*5.30	3.713	21.641
3164	47.50*58.10*5.30	3.753	22.076
3165	48.00*58.60*5.30	3.801	22.326
3166	48.70*59.30*5.30	3.873	22.75
3167	50.00*60.60*5.30	4.126	23.235
3168	51.50*62.10*5.30	4.223	23.72
3169	52.40*63.00*5.30	4.253	24.107
3170	53.00*63.60*5.30	4.308	24.301
3171	54.50*65.10*5.30	4.378	24.786
3172	55.00*65.60*5.30	4.398	24.98
3173	56.00*66.60*5.30	4.402	25.369
3174	58.00*68.60*5.30	4.479	26.241
3175	59.00*69.60*5.30	4.58	26.435
3176	60.00*70.60*5.30	4.479	26.823
3177	61.50*72.10*5.30	4.631	26.823
3178	62.00*72.60*5.30	5.165	26.197
3179	63.00*73.60*5.30	5.226	26.546
3180	64.40*75.00*5.30	5.286	26.895
3181	65.00*75.60*5.30	5.386	26.895
3182	66.00*76.60*5.30	5.485	27.895
3183	67.00*77.60*5.30	5.505	28.895
3184	69.00*79.60*5.30	5.602	29.418
3185	71.00*81.60*5.30	5.71	29.339
3186	73.00*83.60*5.30	5.856	30.808
3187	74.00*84.60*5.30	6.013	31.084
3188	75.00*85.60*5.30	6.153	32.084
3189	77.50*88.10*5.30	6.274	33.084
3190	80.00*90.60*5.30	6.592	34.084
3191	81.00*91.60*5.30	6.647	35.408
3192	82.50*93.10*5.30	6.839	35.943
3193	83.00*93.60*5.30	7.047	35.042
3194	85.00*95.60*5.30	7.274	36.351
3195	87.50*98.10*5.30	7.426	37.223
3196	90.00*100.60*5.30	7.653	38.533
3197	91.00*101.60*5.30	7.791	39.533
3198	92.00*102.60*5.30	7.805	39.405
3199	92.50*103.10*5.30	7.811	39.508
3200	95.00*105.60*5.30	7.829	40.508
3201	97.50*108.10*5.30	7.956	41.508
3202	100.00*110.60*5.30	8.259	42.023
3203	101.80*112.40*5.30	9.017	43.023
3204	103.00*113.60*5.30	9.017	44.023
3205	105.00*115.60*5.30	9.409	45.023
3206	106.00*116.60*5.30	9.228	47.557
3207	108.00*118.60*5.30	8.326	47.173
3208	109.00*119.60*5.30	9.834	47.828
3209	110.00*120.60*5.30	9.531	48.828
3210	112.00*122.60*5.30	9.834	49.828
3211	115.00*125.60*5.30	9.834	50.828
3212	118.00*128.60*5.30	10.44	50.272
3213	120.00*130.60*5.30	11.349	50.272
3214	122.00*132.60*5.30	10.44	50.272
3215	125.00*135.60*5.30	10.454	53.763
3216	128.00*138.60*5.30	10.558	55.141
3217	130.00*140.60*5.30	10.834	55.314
3218	132.00*142.60*5.30	11.349	55.508
3219	136.00*146.60*5.30	11.546	56.508
3220	140.00*150.60*5.30	11.587	59.492
3221	145.00*155.60*5.30	11.652	60.745
3222	148.		

OIL SEAL FACTORY

现货O-型圈 O-RING IN STOCK

序号	规格	丁腈橡胶单价RMB	氟橡胶单价RMB
NO.	SPECIFICATION	NBR PRICE	FKM PRICE
3231	180.00*190.60*5.30	13.79	79.425
3232	185.00*195.60*5.30	14.366	80.425
3233	190.00*200.60*5.30	16.214	87.803
3234	195.00*205.60*5.30	15.62	85.545
3235	200.00*210.60*5.30	15.76	85.185
3236	205.00*215.60*5.30	15.911	86.057
3237	206.00*216.60*5.30	16.128	89.534
3238	209.00*219.60*5.30	16.305	90.421
3239	212.00*222.60*5.30	16.35	95.441
3240	215.00*225.60*5.30	16.452	100.542
3241	218.00*228.60*5.30	16.503	110.369
3242	220.00*230.60*5.30	16.678	127.618
3243	224.00*234.60*5.30	18.151	132.681
3244	230.00*240.60*5.30	18.594	138.266
3245	236.00*246.60*5.30	19.037	139.266
3246	243.00*253.60*5.30	19.554	140.266
3247	245.00*255.60*5.30	19.845	141.266
3248	250.00*260.60*5.30	20.07	141.757
3249	251.00*261.60*5.30	20.144	141.757
3250	258.00*268.60*5.30	20.661	141.757
3251	260.00*270.60*5.30	20.583	142.12
3252	265.00*275.60*5.30	21.178	143.12
3253	272.00*282.60*5.30	21.469	146.471
3254	272.50*283.10*5.30	21.768	147.471
3255	280.00*290.60*5.30	22.285	150.833
3256	285.00*295.60*5.30	22.635	151.833
3257	290.00*300.60*5.30	23.023	152.23
3258	295.00*305.60*5.30	23.167	154.81
3259	300.00*310.60*5.30	23.761	155.81
3260	307.00*317.60*5.30	24.278	159.212
3261	310.00*320.60*5.30	24.302	160.212
3262	315.00*325.60*5.30	24.868	161.212
3263	325.00*335.60*5.30	25.607	172.212
3264	335.00*345.60*5.30	26.345	176.448
3265	340.00*350.60*5.30	26.528	179.125
3266	345.00*355.60*5.30	27.083	181.175
3267	350.00*360.60*5.30	27.942	184.751
3268	355.00*365.60*5.30	27.821	185.015
3269	365.00*375.60*5.30	28.559	186.015
3270	375.00*385.60*5.30	29.297	187.157
3271	387.00*397.60*5.30	30.183	188.299
3272	390.00*400.60*5.30	30.319	189.253
3273	400.00*410.60*5.30	33.918	192.879
3274	412.00*422.60*5.30	35.019	197.23
3275	425.00*435.60*5.30	35.848	201.943
3276	435.00*445.60*5.30	35.993	205.569
3277	437.00*447.60*5.30	36.649	206.569
3278	440.00*450.60*5.30	37.315	207.381
3279	450.00*460.60*5.30	37.609	211.007
3280	460.00*470.60*5.30	39.089	214.633
3281	468.00*478.60*5.30	41.056	217.533
3282	480.00*490.60*5.30	42.686	221.884
3283	485.00*495.60*5.30	43.056	223.697
3284	500.00*510.60*5.30	45.426	229.135
3285	525.00*535.60*5.30	46.797	238.199
3286	545.00*555.60*5.30	47.167	245.45
3287	550.00*560.60*5.30	48.167	247.263
3288	558.00*568.60*5.30	48.537	250.164
3289	620.00*630.60*5.30	54.872	272.642
3290	7.00*17.66*5.33	0.892	7.578
3291	9.00*19.66*5.33	1.026	8.21
3292	10.46*21.12*5.33	1.118	8.723
3293	12.07*22.73*5.33	1.174	8.969
3294	13.64*24.30*5.33	1.352	9.516
3295	15.24*25.90*5.33	1.502	9.798
3296	16.81*27.47*5.33	1.633	10.793
3297	18.42*29.08*5.33	1.796	11.795
3298	19.99*30.65*5.33	1.837	12.142
3299	21.59*32.25*5.33	1.902	12.248
3300	21.99*32.65*5.33	2.027	12.688
3301	23.16*33.82*5.33	2.027	12.96
3302	24.77*35.43*5.33	2.102	13.669

序号	规格	丁腈橡胶单价RMB	氟橡胶单价RMB
NO.	SPECIFICATION	NBR PRICE	FKM PRICE
3303	26.34*37.00*5.33	2.178	14.215
3304	27.94*38.60*5.33	2.296	14.94
3305	29.51*40.17*5.33	2.395	15.515
3306	31.12*41.78*5.33	2.475	15.884
3307	32.00*42.66*5.33	2.542	16.272
3308	32.69*43.35*5.33	2.696	16.507
3309	34.29*44.95*5.33	2.708	17.16
3310	35.00*45.66*5.33	2.854	17.43
3311	37.47*48.13*5.33	2.86	18.36
3312	38.00*48.66*5.33	2.929	18.53
3313	39.00*49.66*5.33	2.936	18.906
3314	40.64*51.30*5.33	3.269	18.906
3315	43.82*54.48*5.33	3.771	19.809
3316	45.00*55.66*5.33	3.492	20.809
3317	46.00*56.66*5.33	3.665	21.809
3318	46.99*57.65*5.33	4.074	21.962
3319	48.00*58.66*5.33	4.167	22.75
3320	48.70*59.36*5.33	4.282	22.944
3321	50.17*60.83*5.33	4.296	23.24
3322	53.34*64.00*5.33	4.315	24.653
3323	56.52*67.18*5.33	4.355	25.65
3324	58.00*68.66*5.33	4.377	26.241
3325	59.69*70.35*5.33	4.808	26.653
3326	61.50*72.16*5.33	5.285	26.895
3327	62.87*73.53*5.33	5.406	26.895
3328	63.17*73.83*5.33	5.346	27.244
3329	66.04*76.70*5.33	5.406	27.942
3330	69.22*79.88*5.33	5.891	30.386
3331	71.00*81.66*5.33	6.096	31.703
3332	72.39*83.05*5.33	6.21	32.703
3333	75.57*86.23*5.33	6.41	33.318
3334	78.74*89.40*5.33	7.198	35.914
3335	80.00*90.66*5.33	6.591	35.914
3336	81.92*92.58*5.33	7.375	36.698
3337	82.50*93.16*5.33	7.696	36.91
3338	85.09*95.75*5.33	7.804	38.096
3339	88.27*98.93*5.33	7.016	38.969
3340	89.34*100.00*5.33	7.258	38.969
3341	90.50*101.16*5.33	7.349	38.969
3342	91.44*102.10*5.33	7.496	38.228
3343	92.50*103.16*5.33	7.501	39.228
3344	94.62*105.28*5.33	7.804	39.405
3345	95.50*106.16*5.33	7.804	40.405
3346	97.79*108.45*5.33	8.41	41.405
3347	98.02*108.68*5.33	8.58	42.601
3348	100.97*111.63*5.33	8.696	42.023
3349	104.14*114.80*5.33	9.227	44.023
3350	105.50*116.16*5.33	9.53	46.023
3351	106.00*116.66*5.33	9.895	47.557
3352	107.32*117.98*5.33	10.136	48.527
3353	110.49*121.15*5.33	10.351	49.527
3354	112.00*122.66*5.33	10.643	49.884
3355	113.67*124.33*5.33	10.742	50.708
3356	115.00*125.66*5.33	10.896	51.708
3357	115.50*126.16*5.33	10.931	51.15
3358	116.00*126.66*5.33	10.973	51.436
3359	116.84*127.50*5.33	10.439	52.436
3360	117.48*128.14*5.33	10.512	53.436
3361	120.02*130.68*5.33	10.696	53.436
3362	120.77*131.43*5.33	10.739	53.436
3363	123.19*133.85*5.33	10.839	53.436
3364	124.00*134.66*5.33	10.896	53.763
3365	125.00*135.66*5.33	10.959	54.634
3366	126.37*137.03*5.33	11.046	55.314
3367	127.50*138.16*5.33	11.117	55.314
3368	129.40*140.06*5.33	11.237	55.702
3369	130.18*140.84*5.33	11.286	56.478
3370	132.72*143.38*5.33	11.446	57.478
3371	133.35*144.01*5.33	11.539	58.478
3372	135.00*145.66*5.33	11.589	58.3
3373	135.89*146.55*5.33	11.645	58.3
3374	138.17*148.83*5.33	11.789	59.463

序号	规格	丁腈橡胶单价RMB	氟橡胶单价RMB
NO.	SPECIFICATION	NBR PRICE	FKM PRICE
3375	139.07*149.73*5.33	12.045	60.463
3376	140.00*150.66*5.33	12.367	61.463
3377	142.24*152.90*5.33	13.789	62.463
3378	144.00*154.66*5.33	13.839	66.857
3379	145.42*156.08*5.33	13.895	73.839
3380	146.05*156.71*5.33	13.998	73.839
3381	147.07*157.73*5.33	14.098	73.839
3382	148.59*159.25*5.33	14.209	74.839
3383	149.23*159.89*5.33	14.573	75.585
3384	151.77*162.43*5.33	14.839	66.857
3385	155.00*165.66*5.33	14.967	68.603
3386	158.12*168.78*5.33	15.202	72.967
3387	161.30*171.96*5.33	15.306	75.694
3388	164.47*175.13*5.33	15.506	76.33
3389	167.70*178.36*5.33	15.707	77.457
3390	170.82*181.48*5.33	15.895	78.123
3391	175.00*185.66*5.33	16.212	79.076
3392	177.07*187.73*5.33	16.367	80.76
3393	183.52*194.18*5.33	16.848	81.76
3394	185.00*195.66*5.33	16.959	82.76
3395	189.87*200.53*5.33	17.323	84.312
3396	193.00*203.66*5.33	17.556	86.057
3397	196.22*206.88*5.33	17.797	86.057
3398	198.00*208.66*5.33	17.929	87.803
3399	200.00*210.66*5.33	18.079	87.803
3400	202.57*213.23*5.33	18.271	87.803
3401	205.00*215.66*5.33	18.452	90.08
3402	208.92*219.58*5.33	18.745	91.518
3403	215.27*225.93*5.33	19.093	94.785
3404	216.00*226.66*5.33	20.839	93.912
3405	221.62*232.28*5.33	22.123	138.266
3406	227.97*238.63*5.33	20.218	139.266
3407	230.00*240.66*5.33	20.305	139.266
3408	234.32*244.98*5.33	20.942	139.266
3409	240.67*251.33*5.33	21.517	140.266
3410	247.02*257.68*5.33	22.729	141.757
3411	250.00*260.66*5.33	22.882	142.757
3412	253.37*264.03*5.33	23.335	141.757
3413	256.70*267.36*5.33	24.548	142.046
3414	266.07*276.73*5.33	25.327	152.23
3415	278.77*289.43*5.33	26.512	155.721
3416	291.47*302.13*5.33	27.697	155.721
3417	304.17*314.83*5.33	28.882	155.721
3418	323.85*334.51*5.33	30.718	166.669
3419	329.57*340.23*5.33	31.252	183.648
3420	345.00*355.66*5.33	32.692	184.648
3421	354.97*365.63*5.33	33.622	190.63
3422	359.97*370.63*5.33	34.089	193.175
3423	368.30*378.96*5.33	34.866	196.666
3424	380.37*391.03*5.33	35.993	197.666
3425	405.26*415.92*5.33	38.315	198.666
3426	422.00*432.66*5.33	39.878	222.048
3427	430.00*440.66*5.33	40.686	223.048
3428	456.06*466.72*5.33	43.056	224.048
3429	481.46*492.12*5.33	45.426	246.484
3430	506.86*517.52*5.33	47.797	247.484
3431	532.26*542.92*5.33	51.167	302.339
3432	557.66*568.32*5.33	53.537	303.339
3433	582.68*593.34*5.33	55.872	312.812
343			

现货O-型圈 O-RING IN STOCK

序号	规格	丁腈橡胶单价RMB	氟橡胶单价RMB
NO.	SPECIFICATION	NBR PRICE	FKM PRICE
3447	30.60*42.00*5.70	2.571	20.324
3448	33.60*45.00*5.70	2.633	20.324
3449	34.60*46.00*5.70	2.9	21.051
3450	38.60*50.00*5.70	2.968	21.633
3451	39.20*50.60*5.70	3.326	21.907
3452	39.60*51.00*5.70	3.58	22.069
3453	40.60*52.00*5.70	3.973	24.019
3454	41.60*53.00*5.70	3.973	24.019
3455	42.60*54.00*5.70	3.973	25.442
3456	43.60*55.00*5.70	3.627	26.442
3457	44.30*55.70*5.70	3.835	27.442
3458	46.30*57.70*5.70	4.352	27.813
3459	47.60*59.00*5.70	4.882	27.813
3460	48.50*59.90*5.70	4.559	27.813
3461	49.20*60.60*5.70	4.673	27.813
3462	49.60*61.00*5.70	4.781	27.813
3463	50.60*62.00*5.70	4.806	28.751
3464	51.60*63.00*5.70	4.831	28.751
3465	52.60*64.00*5.70	4.906	28.751
3466	53.00*64.40*5.70	4.936	29.587
3467	53.60*65.00*5.70	4.636	29.587
3468	54.20*65.60*5.70	4.773	29.587
3469	54.60*66.00*5.70	4.882	29.587
3470	55.60*67.00*5.70	4.906	29.247
3471	56.60*68.00*5.70	5.084	32.177
3472	57.60*69.00*5.70	5.185	33.177
3473	58.60*70.00*5.70	5.428	34.177
3474	59.20*70.60*5.70	5.555	35.177
3475	59.60*71.00*5.70	5.616	35.177
3476	61.60*73.00*5.70	5.788	35.494
3477	61.90*73.30*5.70	5.899	36.376
3478	62.20*73.60*5.70	5.986	36.376
3479	62.60*74.00*5.70	6.012	36.376
3480	63.60*75.00*5.70	6.255	36.376
3481	64.60*76.00*5.70	6.308	36.376
3482	66.60*78.00*5.70	6.321	36.376
3483	68.60*80.00*5.70	6.376	36.376
3484	69.60*81.00*5.70	6.497	36.376
3485	70.60*82.00*5.70	6.509	36.111
3486	71.60*83.00*5.70	6.643	39.411
3487	73.60*85.00*5.70	6.648	40.411
3488	74.60*86.00*5.70	6.746	41.411
3489	76.60*88.00*5.70	6.848	42.413
3490	77.20*88.60*5.70	7.126	43.411
3491	78.00*89.40*5.70	7.428	44.418
3492	78.60*90.00*5.70	7.667	45.419
3493	79.60*91.00*5.70	7.804	46.411
3494	80.60*92.00*5.70	7.836	46.481
3495	82.20*93.60*5.70	7.907	47.411
3496	83.60*95.00*5.70	7.955	48.411
3497	84.60*96.00*5.70	8.41	49.411
3498	86.60*98.00*5.70	7.985	50.411
3499	87.20*98.60*5.70	8.107	52.021
3500	88.00*99.40*5.70	8.107	52.021
3501	88.50*99.90*5.70	8.15	52.896
3502	88.60*100.00*5.70	8.157	52.896
3503	89.60*101.00*5.70	8.41	52.896
3504	90.60*102.00*5.70	8.545	53.896
3505	92.00*103.40*5.70	8.68	54.639
3506	93.60*105.00*5.70	8.72	54.642
3507	94.60*106.00*5.70	9.126	54.673
3508	96.60*108.00*5.70	9.319	54.385
3509	97.00*108.40*5.70	9.358	54.461
3510	97.20*108.60*5.70	9.402	54.639
3511	98.60*110.00*5.70	9.501	54.639
3512	99.60*111.00*5.70	9.925	54.639
3513	100.60*112.00*5.70	9.634	55.13
3514	101.60*113.00*5.70	9.689	55.138
3515	102.60*114.00*5.70	9.773	55.751
3516	103.60*115.00*5.70	9.47	55.005
3517	104.40*115.80*5.70	9.622	55.13
3518	104.60*116.00*5.70	9.758	55.97

序号	规格	丁腈橡胶单价RMB	氟橡胶单价RMB
NO.	SPECIFICATION	NBR PRICE	FKM PRICE
3519	106.60*118.00*5.70	9.804	55.177
3520	108.00*119.40*5.70	9.925	55.97
3521	108.60*120.00*5.70	10.006	56.017
3522	109.60*121.00*5.70	10.261	56.065
3523	110.60*122.00*5.70	10.366	56.051
3524	111.60*123.00*5.70	10.477	56.478
3525	112.60*124.00*5.70	10.545	56.876
3526	113.60*125.00*5.70	10.621	57.254
3527	114.60*126.00*5.70	10.896	57.508
3528	117.60*129.00*5.70	11.261	57.414
3529	118.60*130.00*5.70	11.556	57.254
3530	119.20*130.60*5.70	11.559	57.658
3531	119.60*131.00*5.70	11.651	57.254
3532	123.60*135.00*5.70	11.712	58.999
3533	124.30*135.70*5.70	11.863	58.796
3534	124.60*136.00*5.70	11.954	58.999
3535	128.60*140.00*5.70	12.257	59.999
3536	129.60*141.00*5.70	11.954	59.999
3537	131.20*142.60*5.70	12.065	61.69
3538	131.60*143.00*5.70	13.469	62.49
3539	133.60*145.00*5.70	12.257	63.745
3540	134.00*145.40*5.70	12.696	64.977
3541	134.40*145.80*5.70	12.863	65.348
3542	134.60*146.00*5.70	12.965	66.175
3543	138.60*150.00*5.70	13.166	67.102
3544	139.60*151.00*5.70	13.166	68.727
3545	141.20*152.60*5.70	13.166	69.094
3546	143.60*155.00*5.70	13.031	71.585
3547	144.60*156.00*5.70	13.299	72.309
3548	148.60*160.00*5.70	13.789	73.839
3549	149.20*160.60*5.70	13.886	74.351
3550	149.30*160.70*5.70	13.91	75.803
3551	149.60*161.00*5.70	13.789	76.839
3552	150.00*161.40*5.70	14.395	77.585
3553	153.60*165.00*5.70	13.94	78.712
3554	154.30*165.70*5.70	14.843	79.33
3555	158.60*170.00*5.70	15.919	80.312
3556	159.30*170.70*5.70	15.987	81.567
3557	163.60*175.00*5.70	16.166	82.821
3558	164.30*175.70*5.70	16.471	83.567
3559	168.60*180.00*5.70	16.888	86.407
3560	169.30*180.70*5.70	16.956	87.548
3561	173.60*185.00*5.70	17.003	88.583
3562	174.20*185.60*5.70	17.022	88.835
3563	174.30*185.70*5.70	17.069	89.803
3564	178.60*190.00*5.70	17.287	90.785
3565	179.30*190.70*5.70	17.353	91.294
3566	183.60*195.00*5.70	17.6	92.777
3567	184.30*195.70*5.70	17.626	93.803
3568	188.60*200.00*5.70	18.025	94.596
3569	189.00*200.40*5.70	18.065	95.05
3570	189.30*200.70*5.70	18.09	97.785
3571	193.60*205.00*5.70	18.489	99.148
3572	194.30*205.70*5.70	18.512	99.41
3573	194.60*206.00*5.70	18.581	101.767
3574	198.60*210.00*5.70	18.952	101.767
3575	199.30*210.70*5.70	19.017	101.767
3576	203.60*215.00*5.70	19.848	102.53
3577	204.30*215.70*5.70	19.914	103.276
3578	208.60*220.00*5.70	20.322	104.512
3579	209.30*220.70*5.70	20.388	105.748
3580	213.60*225.00*5.70	21.248	106.276
3581	214.30*225.70*5.70	21.316	108.767
3582	218.60*230.00*5.70	21.733	109.454
3583	219.30*230.70*5.70	21.8	110.494
3584	223.60*235.00*5.70	22.69	141.757
3585	224.30*235.70*5.70	22.759	141.757
3586	228.60*240.00*5.70	23.184	145.248
3587	229.30*240.70*5.70	23.254	148.739
3588	233.60*245.00*5.70	23.679	149.753
3589	234.60*246.00*5.70	23.778	141.757
3590	235.00*246.40*5.70	24	147.34

序号	规格	丁腈橡胶单价RMB	氟橡胶单价RMB
NO.	SPECIFICATION	NBR PRICE	FKM PRICE
3591	238.60*250.00*5.70	25.181	148.85
3592	239.60*251.00*5.70	25.537	149.269
3593	243.60*255.00*5.70	26.211	150.23
3594	244.30*255.70*5.70	26.542	151.739
3595	245.00*256.40*5.70	26.62	151.533
3596	248.60*260.00*5.70	26.998	152.739
3597	249.30*260.70*5.70	27.336	153.648
3598	250.30*261.70*5.70	27.7	153.975
3599	253.60*265.00*5.70	27.796	154.702
3600	258.60*270.00*5.70	28.332	157.237
3601	259.30*270.70*5.70	28.954	166.193
3602	263.60*275.00*5.70	29.424	167.175
3603	268.60*280.00*5.70	30.535	167.117
3604	273.60*285.00*5.70	31.668	168.797
3605	274.60*286.00*5.70	31.781	168.648
3606	278.60*290.00*5.70	32.235	168.624
3607	279.30*290.70*5.70	32.314	169.212
3608	283.60*295.00*5.70	32.802	169.212
3609	284.60*296.00*5.70	32.915	169.797
3610	288.60*300.00*5.70	33.4	169.817
3611	289.30*300.70*5.70	33.448	170.666
3612	293.60*305.00*5.70	33.935	171.914
3613	294.30*305.70*5.70	34.015	173.175
3614	295.00*306.40*5.70	34.1	174.193
3615	299.30*310.70*5.70	34.582	175.684
3616	304.30*315.70*5.70	35	176.684
3617	308.60*320.00*5.70	35.5	177.157
3618	309.30*320.70*5.70	35.716	178.498
3619	310.00*321.40*5.70	35.79	178.791
3620	314.30*325.70*5.70	35.953	179.684
3621	319.30*330.70*5.70	36.179	180.612
3622	324.30*335.70*5.70	36.5	182.968
3623	329.30*340.70*5.70	36.947	185.393
3624	339.30*350.70*5.70	37.695	190.63
3625	344.30*355.70*5.70	37.88	195.466
3626	348.60*360.00*5.70	37.98	200.978
3627	363.60*375.00*5.70	38.3	202.575
3628	368.50*379.90*5.70	38.571	205.102
3629	373.60*385.00*5.70	38.6	207.612
3630	376.00*387.40*5.70	38.7	209.102
3631	378.60*390.00*5.70	38.8	212.559
3632	379.30*390.70*5.70	38.89	216.812
3633	384.40*395.80*5.70	39.003	217.557
3634	388.60*400.00*5.70	39.121	218.812
3635	393.60*405.00*5.70	39.269	219.849
3636	398.60*410.00*5.70	39.3	220.946
3637	408.60*420.00*5.70	39.312	221.139
3638	409.30*420.70*5.70	39.5	221.575
3639	414.30*425.70*5.70	39.336	223.53
3640	418.60*430.00*5.70	39.361	224.333
3641	419.30*430.70*5.70	40.3	224.626
3642	423.60*435.00*5.70	40.5	226.43
3643	429.30*440.70*5.70	41.2	230.812
3644	439.30*450.70*5.70	41.64	233.014
3645	443.60*455.00*5.70	42.23	234.817
3646	448.60*460.00*5.70	42.5	237.757
3647	458.60*470.00*5.70	43.338	240.284
3648	469.50*480.90*5.70	44.083	245.412
3649	483.60*495.00*5.70	44.596	251.591
3650	488.60*500.00*5.70	45.89	253.688

OIL SEAL FACTORY

现货O-型圈 O-RING IN STOCK

序号	规格	丁腈橡胶单价RMB	氟橡胶单价RMB
NO.	SPECIFICATION	NBR PRICE	FKM PRICE
3663	553.50*565.10*5.80	72.5	279.648
3664	12.00*24.00*6.00	2.143	12.034
3665	17.00*29.00*6.00	2.93	14.251
3666	18.00*30.00*6.00	3.029	14.597
3667	20.00*32.00*6.00	3.102	16.362
3668	22.00*34.00*6.00	3.141	16.486
3669	23.00*35.00*6.00	3.253	16.942
3670	24.00*36.00*6.00	3.35	17.433
3671	25.00*37.00*6.00	3.4	18.386
3672	28.00*40.00*6.00	3.45	19.841
3673	30.00*42.00*6.00	3.534	20.301
3674	30.50*42.50*6.00	3.55	21.149
3675	32.00*44.00*6.00	3.65	22.205
3676	35.00*47.00*6.00	3.795	22.506
3677	36.00*48.00*6.00	3.85	23.705
3678	38.00*50.00*6.00	3.949	24.924
3679	39.00*51.00*6.00	4.268	25.898
3680	40.00*52.00*6.00	4.428	26.288
3681	42.00*54.00*6.00	4.535	27.908
3682	45.00*57.00*6.00	4.825	28.151
3683	47.00*59.00*6.00	4.886	28.665
3684	48.00*60.00*6.00	4.68	29.15
3685	50.00*62.00*6.00	4.933	30.023
3686	53.00*65.00*6.00	4.964	31.38
3687	54.00*66.00*6.00	5.2	32.088
3688	55.00*67.00*6.00	5.475	32.35
3689	56.00*68.00*6.00	5.825	33.835
3690	58.00*70.00*6.00	6.283	33.748
3691	60.00*72.00*6.00	6.757	34.677
3692	61.00*73.00*6.00	6.859	35.68
3693	62.00*74.00*6.00	6.95	35.647
3694	65.00*77.00*6.00	6.97	37.507
3695	68.00*80.00*6.00	7.1	38.197
3696	70.00*82.00*6.00	7.2	39.054
3697	73.00*85.00*6.00	7.312	41.278
3698	75.00*87.00*6.00	7.497	42.186
3699	76.00*88.00*6.00	7.59	43.368
3700	78.00*90.00*6.00	7.892	45.228
3701	80.00*92.00*6.00	8.108	46.827
3702	81.00*93.00*6.00	8.808	47.964
3703	83.00*95.00*6.00	8.856	49.036
3704	85.00*97.00*6.00	9.012	50.687
3705	88.00*100.00*6.00	9.237	52.642
3706	90.00*102.00*6.00	9.456	53.293
3707	92.80*104.80*6.00	9.622	54.642
3708	95.00*107.00*6.00	9.923	55.469
3709	98.00*110.00*6.00	10.2	55.798
3710	100.00*112.00*6.00	10.525	55.896
3711	103.00*115.00*6.00	10.808	55.97
3712	107.00*119.00*6.00	11.348	56.508
3713	108.00*120.00*6.00	11.752	57.836
3714	109.00*121.00*6.00	11.888	60.857
3715	111.00*123.00*6.00	11.901	62.043
3716	112.00*124.00*6.00	12.142	63.81
3717	114.00*126.00*6.00	12.156	64.254
3718	115.00*127.00*6.00	12.257	66.857
3719	118.00*130.00*6.00	12.365	67.745
3720	120.00*132.00*6.00	12.446	68.603
3721	122.00*134.00*6.00	12.56	70.49
3722	126.00*138.00*6.00	13.02	71.458
3723	128.00*140.00*6.00	13.183	71.217
3724	130.00*142.00*6.00	13.789	72.585
3725	135.00*147.00*6.00	14.395	74.963
3726	138.00*150.00*6.00	14.592	76.593
3727	140.00*152.00*6.00	15.001	78.708
3728	141.00*153.00*6.00	16.08	80.872
3729	142.00*154.00*6.00	16.99	83.265
3730	145.00*157.00*6.00	17.99	84.785
3731	148.00*160.00*6.00	18.141	84.312
3732	150.00*162.00*6.00	18.377	86.319
3733	153.00*165.00*6.00	18.73	87.803
3734	154.00*166.00*6.00	19.297	88.803

序号	规格	丁腈橡胶单价RMB	氟橡胶单价RMB
NO.	SPECIFICATION	NBR PRICE	FKM PRICE
3735	155.00*167.00*6.00	19.417	88.057
3736	158.00*170.00*6.00	19.7	89.321
3737	160.00*172.00*6.00	20.02	89.548
3738	163.00*175.00*6.00	20.38	90.812
3739	165.00*177.00*6.00	20.623	91.992
3740	170.00*182.00*6.00	21.226	94.57
3741	172.00*184.00*6.00	21.467	96.421
3742	175.00*187.00*6.00	22.1	97.793
3743	180.00*192.00*6.00	22.432	98.748
3744	185.00*197.00*6.00	23.3	98.276
3745	188.00*200.00*6.00	23.397	99.934
3746	190.00*202.00*6.00	23.638	100.839
3747	193.00*205.00*6.00	24	105.021
3748	200.00*212.00*6.00	24.844	110.534
3749	205.00*217.00*6.00	25.447	115.908
3750	206.00*218.00*6.00	25.568	120.327
3751	208.00*220.00*6.00	25.809	125.217
3752	210.00*222.00*6.00	26.05	130.876
3753	211.00*223.00*6.00	26.171	135.985
3754	215.00*227.00*6.00	26.5	140.603
3755	220.00*232.00*6.00	27.1	145.23
3756	222.00*234.00*6.00	27.5	150.23
3757	225.00*237.00*6.00	27.859	153.648
3758	228.00*240.00*6.00	28.221	155.721
3759	230.00*242.00*6.00	28.462	156.739
3760	232.00*244.00*6.00	28.668	157.388
3761	234.00*246.00*6.00	28.9	159.212
3762	235.00*247.00*6.00	29.065	159.548
3763	237.00*249.00*6.00	29.3	159.212
3764	238.00*250.00*6.00	29.427	160.176
3765	240.00*252.00*6.00	29.668	161.23
3766	245.00*257.00*6.00	30.271	162.702
3767	248.00*260.00*6.00	30.633	163.212
3768	250.00*262.00*6.00	30.88	164.012
3769	255.00*267.00*6.00	31.477	165.684
3770	256.00*268.00*6.00	31.598	166.539
3771	257.00*269.00*6.00	32.1	167.004
3772	258.00*270.00*6.00	32.26	168.684
3773	259.00*271.00*6.00	32.38	169.702
3774	260.00*272.00*6.00	32.5	170.702
3775	265.00*277.00*6.00	32.684	171.684
3776	267.00*279.00*6.00	34.46	173.175
3777	268.00*280.00*6.00	34.582	175.175
3778	275.00*287.00*6.00	35.86	176.412
3779	276.00*288.00*6.00	38.36	177.832
3780	280.00*292.00*6.00	39.2	178.684
3781	285.00*297.00*6.00	39.99	180.014
3782	290.00*302.00*6.00	40.265	183.666
3783	299.00*311.00*6.00	41.305	187.52
3784	299.30*311.30*6.00	41.53	188.659
3785	300.00*312.00*6.00	42.1	189.666
3786	305.00*317.00*6.00	42.305	190.63
3787	307.00*319.00*6.00	43.5	192.026
3788	308.00*320.00*6.00	44.5	195.724
3789	310.00*322.00*6.00	44.9	198.084
3790	315.00*327.00*6.00	45.916	200.557
3791	320.00*332.00*6.00	46.5	201.63
3792	328.00*340.00*6.00	48.713	203.63
3793	330.00*342.00*6.00	50.418	204.612
3794	335.00*347.00*6.00	52.603	205.247
3795	340.00*352.00*6.00	53.5	208.084
3796	345.00*357.00*6.00	54.145	211.102
3797	350.00*362.00*6.00	54.917	212.217
3798	360.00*372.00*6.00	57.2	215.084
3799	368.00*380.00*6.00	57.693	218.557
3800	380.00*392.00*6.00	59.544	225.539
3801	390.00*402.00*6.00	62.1	227.284
3802	400.00*412.00*6.00	64.1	235.45
3803	410.00*422.00*6.00	66.1	236.521
3804	430.00*442.00*6.00	67.257	249.39
3805	445.00*457.00*6.00	69.571	256.359
3806	450.00*462.00*6.00	73.5	260.993

序号	规格	丁腈橡胶单价RMB	氟橡胶单价RMB
NO.	SPECIFICATION	NBR PRICE	FKM PRICE
3807	470.00*482.00*6.00	77.5	267.976
3808	530.00*542.00*6.00	82.5	295.855
3809	540.00*552.00*6.00	84.226	300.502
3810	560.00*572.00*6.00	88.5	309.321
3811	580.00*592.00*6.00	92.5	316.302
3812	53.00*65.40*6.20	5.387	32.35
3813	12.70*25.70*6.50	2.426	16.648
3814	14.50*27.50*6.50	2.941	18.023
3815	15.88*28.88*6.50	3.09	19.549
3816	19.05*32.05*6.50	3.142	20.273
3817	44.45*57.45*6.50	5.063	35.086
3818	51.80*64.80*6.50	6.134	37.088
3819	54.00*67.00*6.50	6.96	41.351
3820	69.85*82.85*6.50	7.489	56.385
3821	127.00*140.00*6.50	14.65	86.93
3822	142.00*155.00*6.50	17.52	128.537
3823	183.00*196.00*6.50	23.5	150.895
3824	34.29*48.27*6.99	5.164	32.201
3825	37.47*51.45*6.99	5.546	34.666
3826	40.64*54.62*6.99	5.666	37.223
3827	43.82*57.80*6.99	5.758	39.187
3828	46.99*60.97*6.99	5.95	41.201
3829	50.17*64.15*6.99	6.4	44.123
3830	53.34*67.32*6.99	6.46	46.123
3831	56.52*70.50*6.99	7.588	49.496
3832	59.60*73.58*6.99	7.666	48.163
3833	69.22*83.20*6.99	7.8	56.031
3834	71.00*84.98*6.99	8.8	57.381
3835	72.39*86.37*6.99	9.319	59.348
3836	75.57*89.55*6.99	9.701	61.364
3837	78.50*92.48*6.99	9.925	65.369
3838	81.00*94.98*6.99	10.228	68.369
3839	85.09*99.07*6.99	11.444	69.481
3840	91.44*105.42*6.99	12.863	70.348
3841	94.62*108.60*6.99	12.863	70.348
3842	96.00*109.98*6.99	12.996	72.109
3843	100.97*114.95*6.99	13.469	73.727
3844	107.32*121.30*6.99	14.075	76.217
3845	110.49*124.47*6.99	14.984	78.567
3846	113.67*127.65*6.99	15.287	80.454
3847	116.84*130.82*6.99	14.681	81.69
3848	120.02*134.00*6.99	14.996	82.69
3849	123.19*137.17*6.99	15.893	84.69
3850	124.60*138.58*6.99	15.893	85.927
3851	126.37*140.35*6.99	15.996	86.436
3852	129.54*143.52*6.99	16.196	87.436
3853	132.72*146.70*6.99	17.105	88.672
3854	135.89*149.87*6.99	17.105	90.672
3855	139.07*153.05*6.99	17.122	93.039
3856	142.24*156.22*6.99	18.031	102.639
3857	145.42*159.40*6.99	18.94	104.457
3858	148.59*162.57*6.99	18.637	106.13
3859	151.77*165.75*6.99	19.244	108.639
3860	156.12*170.10*6.99	20.456	112.239
3861	158.12*172.10*6.99	20.547	114.367
3862	164.47*178.45*6.99	21.062	115.73
3863	167.47*181.45*6.99	21.194	117.73
3864	168.30*182.28*6.99	21.524	118.203
3865	170.82*184.80*6.99	21.668	119.221
3866	177.17*191.15*6.99	22.1	119.221
3867	180.50*194.48*6.99	22.499	119.221
3868			

现货O-型圈 O-RING IN STOCK

序号	规格	丁腈橡胶单价RMB	氟橡胶单价RMB
NO.	SPECIFICATION	NBR PRICE	FKM PRICE
3879	253.37*267.35*6.99	32.472	200.63
3880	259.00*272.98*6.99	34.851	211.575
3881	266.06*280.04*6.99	37.275	225.539
3882	278.77*292.75*6.99	36.063	230.557
3883	285.10*299.08*6.99	38.525	232.624
3884	291.47*305.45*6.99	39.093	236.012
3885	304.17*318.15*6.99	40.911	246.484
3886	316.87*330.85*6.99	40.985	248.502
3887	329.57*343.55*6.99	41.185	263.939
3888	342.27*356.25*6.99	41.807	274.412
3889	354.97*368.95*6.99	42.123	280.448
3890	367.67*381.65*6.99	42.185	295.357
3891	380.37*394.35*6.99	44.762	295.357
3892	393.07*407.05*6.99	46.823	296.884
3893	405.26*419.24*6.99	52.525	300.884
3894	417.96*431.94*6.99	56.661	316.411
3895	430.66*444.64*6.99	58.354	318.83
3896	443.36*457.34*6.99	60.048	332.43
3897	456.06*470.04*6.99	61.741	341.539
3898	468.76*482.74*6.99	63.434	348.448
3899	481.46*495.44*6.99	72.364	356.457
3900	494.16*508.14*6.99	74.246	364.466
3901	506.86*520.84*6.99	76.127	382.484
3902	532.26*546.24*6.99	87.879	398.193
3903	552.24*566.22*6.99	91.135	401.094
3904	557.66*571.64*6.99	100.384	404.512
3905	582.68*596.66*6.99	104.832	407.066
3906	16.00*30.00*7.00	2.557	19.669
3907	17.00*31.00*7.00	2.878	20.294
3908	18.00*32.00*7.00	2.911	21.024
3909	20.65*34.65*7.00	3.041	24.359
3910	22.00*36.00*7.00	3.163	25.433
3911	23.80*37.80*7.00	3.341	26.574
3912	25.00*39.00*7.00	3.528	27.409
3913	25.40*39.40*7.00	3.688	28.586
3914	26.00*40.00*7.00	3.72	28.084
3915	27.00*41.00*7.00	3.73	28.397
3916	28.58*42.58*7.00	3.87	28.207
3917	30.00*44.00*7.00	3.923	28.442
3918	30.18*44.18*7.00	4.47	30.876
3919	31.75*45.75*7.00	4.6	31.869
3920	33.00*47.00*7.00	4.71	32.413
3921	35.00*49.00*7.00	5.164	33.62
3922	37.00*51.00*7.00	5.276	34.943
3923	40.00*54.00*7.00	5.488	36.787
3924	43.00*57.00*7.00	5.69	37.295
3925	49.00*63.00*7.00	6.398	41.077
3926	50.00*64.00*7.00	6.898	43.227
3927	52.00*66.00*7.00	7.125	45.409
3928	55.00*69.00*7.00	7.165	47.307
3929	56.00*70.00*7.00	7.165	49.494
3930	58.00*72.00*7.00	7.56	50.271
3931	60.00*74.00*7.00	7.588	51.824
3932	62.00*76.00*7.00	7.676	51.827
3933	63.00*77.00*7.00	7.952	52.494
3934	64.00*78.00*7.00	8.048	53.091
3935	66.00*80.00*7.00	8.194	53.309
3936	68.00*82.00*7.00	8.661	53.621
3937	71.00*85.00*7.00	8.922	57.381
3938	76.00*90.00*7.00	10.228	59.696
3939	77.50*91.50*7.00	10.286	60.62
3940	78.00*92.00*7.00	10.335	61.005
3941	80.00*94.00*7.00	10.4	63.072
3942	81.00*95.00*7.00	10.498	63.842
3943	82.00*96.00*7.00	10.595	63.466
3944	83.00*97.00*7.00	10.692	64.098
3945	86.00*100.00*7.00	11.137	65.805
3946	88.00*102.00*7.00	11.224	67.114
3947	90.00*104.00*7.00	11.44	68.205
3948	91.00*105.00*7.00	11.509	69.158
3949	92.00*106.00*7.00	11.794	69.79
3950	93.00*107.00*7.00	11.986	70.351

序号	规格	丁腈橡胶单价RMB	氟橡胶单价RMB
NO.	SPECIFICATION	NBR PRICE	FKM PRICE
3951	95.00*109.00*7.00	12.171	72.094
3952	96.00*110.00*7.00	12.349	73.587
3953	98.00*112.00*7.00	12.501	74.46
3954	100.00*114.00*7.00	12.804	75.205
3955	101.00*115.00*7.00	12.837	76.622
3956	103.00*117.00*7.00	13.2	77.708
3957	104.00*118.00*7.00	13.379	78.519
3958	105.00*119.00*7.00	13.469	79.587
3959	106.00*120.00*7.00	13.584	80.784
3960	107.00*121.00*7.00	13.687	81.587
3961	108.00*122.00*7.00	14.075	82.217
3962	109.00*123.00*7.00	14.232	83.708
3963	112.00*126.00*7.00	14.341	84.466
3964	113.00*127.00*7.00	14.615	85.466
3965	114.00*128.00*7.00	14.633	86.956
3966	115.00*129.00*7.00	14.712	87.476
3967	116.00*130.00*7.00	14.743	88.108
3968	117.00*131.00*7.00	14.833	89.187
3969	118.00*132.00*7.00	14.893	90.373
3970	120.00*134.00*7.00	14.963	91.638
3971	122.00*136.00*7.00	15.183	92.903
3972	125.00*139.00*7.00	15.513	93.801
3973	126.00*140.00*7.00	15.893	94.69
3974	128.00*142.00*7.00	16.063	95.999
3975	130.00*144.00*7.00	17.375	96.224
3976	135.00*149.00*7.00	17.499	97.181
3977	136.00*150.00*7.00	17.647	98.345
3978	138.00*152.00*7.00	17.661	107.135
3979	140.00*154.00*7.00	17.743	110.636
3980	145.00*159.00*7.00	17.963	115.73
3981	148.00*162.00*7.00	18.193	116.46
3982	150.00*164.00*7.00	18.661	117.767
3983	155.00*169.00*7.00	19.255	118.887
3984	157.00*171.00*7.00	19.797	119.512
3985	158.00*172.00*7.00	20.102	120.239
3986	160.00*174.00*7.00	20.346	121.049
3987	164.00*178.00*7.00	20.833	125.73
3988	165.00*179.00*7.00	20.955	127.912
3989	170.00*184.00*7.00	21.301	128.373
3990	175.00*189.00*7.00	21.903	130.536
3991	176.00*190.00*7.00	22.023	132.73
3992	180.00*194.00*7.00	22.577	133.457
3993	183.00*197.00*7.00	22.866	135.694
3994	185.00*199.00*7.00	23.106	136.86
3995	188.00*202.00*7.00	23.467	138.757
3996	190.00*204.00*7.00	23.708	139.203
3997	195.00*209.00*7.00	24.01	140.948
3998	197.00*211.00*7.00	24.247	143.73
3999	198.00*212.00*7.00	24.366	145.082
4000	200.00*214.00*7.00	24.604	146.347
4001	205.00*219.00*7.00	25.198	149.509
4002	206.00*220.00*7.00	25.317	149.767
4003	207.50*221.50*7.00	25.495	150.312
4004	208.00*222.00*7.00	25.555	155.676
4005	210.00*224.00*7.00	25.8	166.193
4006	212.00*226.00*7.00	26.03	168.185
4007	216.00*230.00*7.00	26.51	170.666
4008	218.00*232.00*7.00	27.578	172.684
4009	224.00*238.00*7.00	27.604	173.175
4010	227.00*241.00*7.00	27.886	186.432
4011	229.00*243.00*7.00	28.184	190.63
4012	230.00*244.00*7.00	28.764	198.329
4013	235.00*249.00*7.00	28.79	200.139
4014	236.00*250.00*7.00	28.886	202.124
4015	237.00*251.00*7.00	29.002	203.63
4016	240.00*254.00*7.00	29.361	204.653
4017	241.00*255.00*7.00	30.608	205.139
4018	242.00*256.00*7.00	30.696	205.918
4019	243.00*257.00*7.00	30.815	206.121
4020	250.00*264.00*7.00	31.265	208.084
4021	254.00*268.00*7.00	31.385	209.612
4022	258.00*272.00*7.00	31.82	210.121

序号	规格	丁腈橡胶单价RMB	氟橡胶单价RMB
NO.	SPECIFICATION	NBR PRICE	FKM PRICE
4023	265.00*279.00*7.00	32.426	215.612
4024	272.00*286.00*7.00	32.426	218.612
4025	280.00*294.00*7.00	34.245	229.03
4026	283.00*297.00*7.00	34.512	230.539
4027	290.00*304.00*7.00	34.851	235.575
4028	295.00*309.00*7.00	35.112	239.438
4029	300.00*314.00*7.00	35.429	242.6
4030	306.00*320.00*7.00	35.849	246.395
4031	307.00*321.00*7.00	36.063	248.557
4032	315.00*329.00*7.00	38.889	253.466
4033	320.00*334.00*7.00	39.106	257.757
4034	325.00*339.00*7.00	39.366	259.466
4035	335.00*349.00*7.00	39.699	260.502
4036	340.00*354.00*7.00	39.849	267.898
4037	345.00*359.00*7.00	40.709	271.061
4038	350.00*364.00*7.00	40.899	274.223
4039	355.00*369.00*7.00	41.287	277.385
4040	360.00*374.00*7.00	41.758	280.547
4041	365.00*379.00*7.00	42.005	283.71
4042	370.00*384.00*7.00	42.849	285.412
4043	375.00*389.00*7.00	43.702	290.034
4044	380.00*394.00*7.00	44.849	293.448
4045	387.00*401.00*7.00	45.76	294.412
4046	393.00*407.00*7.00	46.96	301.418
4047	395.00*409.00*7.00	48.976	305.375
4048	400.00*414.00*7.00	52.004	310.357
4049	412.00*426.00*7.00	56.028	313.435
4050	420.00*434.00*7.00	57.187	318.494
4051	425.00*439.00*7.00	57.766	320.302
4052	426.00*440.00*7.00	57.962	322.289
4053	433.00*447.00*7.00	58.555	323.066
4054	437.00*451.00*7.00	59.371	323.284
4055	440.00*454.00*7.00	60.112	331.143
4056	445.00*459.00*7.00	61.976	334.305
4057	450.00*464.00*7.00	61.109	338.83
4058	455.00*469.00*7.00	62.006	340.63
4059	462.00*476.00*7.00	62.713	341.248
4060	475.00*489.00*7.00	64.452	345.157
4061	487.00*501.00*7.00	73.396	350.248
4062	490.00*504.00*7.00	74.109	362.766
4063	500.00*514.00*7.00	75.327	368.09
4064	515.00*529.00*7.00	77.556	375.175
4065	520.00*534.00*7.00	82.327	381.739
4066	530.00*544.00*7.00	87.763	388.064
4067	540.00*554.00*7.00	89.556	394.388
4068	545.00*559.00*7.00	90.215	403.03
4069	550.00*564.00*7.00	96.2	405.713
4070	560.00*574.00*7.00	101.09	407.037
4071	580.00*594.00*7.00	104.656	419.686
4072	105.00*120.00*7.50	18.9	98.126
4073	115.00*130.00*7.50	19.699	124.302
4074	120.00*135.00*7.50	20.9	142.025
4075	126.50*141.50*7.50	21.9	145.03
4076	130.00*145.00*7.50	22.9	148.257
4077	19.00*35.00*8.00	4.619	32.58
4078	20.00*36.00*8.00	4.733	33.34
4079	23.80*39.80*8.00	5.269	37.278
4080	25.40*41.40*8.00	5.52	38

现货O-型圈 O-RING IN STOCK

序号	规格	丁腈橡胶单价RMB	氟橡胶单价RMB
NO.	SPECIFICATION	NBR PRICE	FKM PRICE
4095	62.00*78.00*8.00	10.494	72.133
4096	63.50*79.50*8.00	10.65	73.081
4097	66.67*82.67*8.00	11.343	75.408
4098	69.85*85.85*8.00	11.357	85.652
4099	73.00*89.00*8.00	12.016	88.854
4100	76.10*92.10*8.00	12.555	93.806
4101	76.50*92.50*8.00	12.831	97.413
4102	79.37*95.37*8.00	13.055	100.551
4103	82.55*98.55*8.00	13.406	103.414
4104	85.72*101.72*8.00	13.767	105.788
4105	88.89*104.89*8.00	15.607	108.403
4106	92.00*108.00*8.00	15.613	110.217
4107	95.00*111.00*8.00	15.585	113.698
4108	98.42*114.42*8.00	15.888	116.26
4109	101.60*117.60*8.00	16.987	118.006
4110	105.00*121.00*8.00	17.381	121.958
4111	108.00*124.00*8.00	18.81	123.434
4112	110.00*126.00*8.00	19.5	125.973
4113	115.00*131.00*8.00	21.2	126.512
4114	120.00*136.00*8.00	21.2	128.636
4115	125.00*141.00*8.00	22.7	129.73
4116	127.00*143.00*8.00	22.699	130.129
4117	130.00*146.00*8.00	23.2	133.494
4118	133.00*149.00*8.00	23.495	134.085
4119	135.00*151.00*8.00	23.8	138.108
4120	139.00*155.00*8.00	23.879	139.041
4121	140.00*156.00*8.00	24.031	143.721
4122	145.00*161.00*8.00	24.8	145.203
4123	146.00*162.00*8.00	24.888	147.948
4124	148.00*164.00*8.00	26.063	150.957
4125	150.00*166.00*8.00	25.5	155.694
4126	152.00*168.00*8.00	25.298	159.78
4127	160.00*176.00*8.00	26.5	160.167
4128	162.00*178.00*8.00	26.9	165.894
4129	165.00*181.00*8.00	28.5	170.528
4130	170.00*186.00*8.00	29.093	178.412
4131	175.00*191.00*8.00	30.002	183.648
4132	180.00*196.00*8.00	30.5	186.621
4133	185.00*201.00*8.00	31.419	190.63
4134	190.00*206.00*8.00	32.2	193.112
4135	195.00*211.00*8.00	33.321	197.612
4136	196.00*212.00*8.00	33.469	201.575
4137	200.00*216.00*8.00	34.1	205.612
4138	203.00*219.00*8.00	34.567	207.612
4139	210.00*226.00*8.00	35.5	210.076
4140	215.00*231.00*8.00	36.331	214.83
4141	216.00*232.00*8.00	36.478	219.575
4142	220.00*236.00*8.00	37.1	223.961
4143	230.00*246.00*8.00	38.5	227.633
4144	233.00*249.00*8.00	39.211	229.03
4145	235.00*251.00*8.00	39.525	235.539
4146	238.00*254.00*8.00	39.992	253.466
4147	240.00*256.00*8.00	40.3	255.482
4148	250.00*266.00*8.00	42.332	256.484
4149	260.00*276.00*8.00	43.921	272.003
4150	270.00*286.00*8.00	45.511	283.466
4151	310.00*326.00*8.00	51.856	288.375
4152	315.00*331.00*8.00	52.651	311.393
4153	355.00*371.00*8.00	59	321.539
4154	360.00*376.00*8.00	59.8	330.793
4155	380.00*396.00*8.00	61.5	371.129
4156	350.00*366.20*8.10	60.439	354.123
4157	58.00*74.40*8.20	12.626	79.24
4158	61.00*77.80*8.40	13.934	81.857
4159	75.00*91.80*8.40	14.072	105.61
4160	80.00*96.80*8.40	15.304	109.278
4161	85.72*102.52*8.40	16.213	112.769
4162	90.00*106.80*8.40	16.866	119.271
4163	95.00*111.80*8.40	17.728	120.006
4164	98.42*115.22*8.40	18.637	121.767
4165	105.00*121.80*8.40	19.547	127.003
4166	110.00*126.80*8.40	20.316	132.483

序号	规格	丁腈橡胶单价RMB	氟橡胶单价RMB
NO.	SPECIFICATION	NBR PRICE	FKM PRICE
4167	115.00*131.80*8.40	21.272	137.039
4168	120.00*136.80*8.40	21.931	139.59
4169	123.20*140.00*8.40	21.668	143.108
4170	125.00*141.80*8.40	21.88	152.23
4171	130.00*146.80*8.40	22.651	157.466
4172	135.00*151.80*8.40	23.789	161.439
4173	140.00*156.80*8.40	24.395	164.93
4174	144.10*160.90*8.40	25.018	167.539
4175	149.50*166.30*8.40	25.696	168.167
4176	154.50*171.30*8.40	26.51	170.094
4177	159.50*176.30*8.40	27.324	172.094
4178	164.50*181.30*8.40	28.637	174.367
4179	169.50*186.30*8.40	28.951	175.548
4180	174.50*191.30*8.40	29.765	177.694
4181	179.50*196.30*8.40	31.365	179.076
4182	184.50*201.30*8.40	31.392	180.076
4183	189.50*206.30*8.40	32.94	184.152
4184	194.50*211.30*8.40	33.02	185.548
4185	199.50*216.30*8.40	33.833	195.548
4186	204.50*221.30*8.40	34.647	200.547
4187	208.50*225.30*8.40	35.298	210.53
4188	209.50*226.30*8.40	36.063	218.557
4189	214.50*231.30*8.40	36.275	221.33
4190	219.50*236.30*8.40	37.275	225.539
4191	224.50*241.30*8.40	37.902	239.502
4192	229.10*245.90*8.40	38.716	267.959
4193	229.50*246.30*8.40	38.716	268.323
4194	234.50*251.30*8.40	40.305	272.993
4195	239.50*256.30*8.40	42.123	274.466
4196	244.50*261.30*8.40	43.335	276.448
4197	249.50*266.30*8.40	43.335	280.957
4198	254.50*271.30*8.40	43.598	285.091
4199	259.50*276.30*8.40	43.598	288.375
4200	264.50*281.30*8.40	44.411	293.939
4201	269.50*286.30*8.40	46.972	298.393
4202	274.50*291.30*8.40	47.039	303.306
4203	279.50*296.30*8.40	48.853	305.83
4204	284.50*301.30*8.40	50.608	307.339
4205	289.50*306.30*8.40	51.48	309.375
4206	294.50*311.30*8.40	52.154	313.375
4207	299.50*316.30*8.40	52.967	318.375
4208	309.50*326.30*8.40	54.245	320.284
4209	314.50*331.30*8.40	54.426	322.812
4210	319.50*336.30*8.40	56.222	328.284
4211	330.00*346.80*8.40	57.377	330.266
4212	334.50*351.30*8.40	58.663	333.284
4213	339.50*356.30*8.40	59.477	340.266
4214	344.50*361.30*8.40	60.291	343.666
4215	354.50*371.30*8.40	61.918	344.23
4216	359.50*376.30*8.40	62.732	347.721
4217	369.50*386.30*8.40	64.359	358.193
4218	374.50*391.30*8.40	65.173	368.666
4219	384.50*401.30*8.40	66.8	370.193
4220	399.50*416.30*8.40	69.241	410.157
4221	410.00*426.80*8.40	70.95	432.709
4222	419.50*436.30*8.40	72.496	445.612
4223	434.00*450.80*8.40	74.856	454.567
4224	459.00*475.80*8.40	78.924	475.03
4225	485.00*501.80*8.40	88.336	501.014
4226	499.50*516.30*8.40	90.848	514.219
4227	500.00*516.80*8.40	90.934	516.675
4228	504.50*521.30*8.40	105.177	518.773
4229	514.50*531.30*8.40	109.802	536.884
4230	523.85*540.65*8.40	111.765	553.866
4231	530.00*546.80*8.40	118.709	563.884
4232	534.00*550.80*8.40	119.591	584.404
4233	155.00*172.00*8.50	26.392	171.4
4234	205.50*222.50*8.50	37.275	218.493
4235	216.50*233.50*8.50	41.203	261.759
4236	226.00*243.00*8.50	45.459	279.502
4237	275.00*292.00*8.50	50.38	316.313
4238	280.00*297.00*8.50	51.832	320.976

序号	规格	丁腈橡胶单价RMB	氟橡胶单价RMB
NO.	SPECIFICATION	NBR PRICE	FKM PRICE
4239	393.50*410.50*8.50	66.381	426.819
4240	413.50*430.50*8.50	68.09	445.47
4241	473.50*490.50*8.50	84.247	462.921
4242	493.50*510.50*8.50	86.247	462.921
4243	498.00*515.00*8.50	88.5	478.63
4244	583.50*600.50*8.50	140.1	560.666
4245	19.80*37.00*8.60	6.192	36.012
4246	22.30*39.50*8.60	6.737	38.379
4247	51.30*68.50*8.60	10.774	56.883
4248	80.80*98.00*8.60	14.619	96.351
4249	82.80*100.00*8.60	14.946	98.096
4250	92.80*110.00*8.60	16.591	107.696
4251	97.80*115.00*8.60	17.399	112.496
4252	102.80*120.00*8.60	18.216	113.496
4253	107.80*125.00*8.60	19.034	115.405
4254	112.80*130.00*8.60	22.089	117.375
4255	122.80*140.00*8.60	23.687	127.072
4256	127.80*145.00*8.60	24.122	135.581
4257	132.80*150.00*8.60	24.757	140.436
4258	137.80*155.00*8.60	25.304	146.89
4259	142.80*160.00*8.60	25.394	150.639
4260	147.80*165.00*8.60	26.015	155.639
4261	152.80*170.00*8.60	26.392	160.876
4262	157.80*175.00*8.60	27.21	165.457
4263	162.80*180.00*8.60	28.637	170.367
4264	167.80*185.00*8.60	29.246	175.857
4265	172.80*190.00*8.60	30.663	185.548
4266	177.80*195.00*8.60	31.48	190.839
4267	182.80*200.00*8.60	32.298	195.421
4268	187.80*205.00*8.60	33.663	200.457
4269	192.80*210.00*8.60	35.751	210.385
4270	197.80*215.00*8.60	37.275	215.53
4271	202.80*220.00*8.60	38.568	220.457
4272	207.80*225.00*8.60	39.699	225.494
4273	212.80*230.00*8.60	40.203	230.003
4274	217.80*235.00*8.60	41.203	235.457
4275	222.80*240.00*8.60	42.339	240.484
4276	227.80*245.00*8.60	43.656	246.484
4277	232.80*250.00*8.60	44.676	256.957
4278	237.80*255.00*8.60	45.292	267.437
4279	242.80*260.00*8.60	45.76	277.902
4280	247.80*265.00*8.60	46.927	287.983
4281	252.80*270.00*8.60	47.744	290.393
4282	257.80*275.00*8.60	49.396	295.357
4283	262.80*280.00*8.60	50.38	302.339
4284	267.80*285.00*8.60	51.197	312.884
4285	272.80*290.00*8.60	51.832	323.284
4286	277.80*295.00*8.60	51.832	325.622
4287	282.80*300.00*8.60	52.015	330.395
4288	287.80*305.00*8.60	52.468	335.168
4289	292.80*310.00*8.60	52.832	338.321
4290	297.80*315.00*8.60	53.103	340.812
4291	302.80*320.00*8.60	53.92	345.487
4292	307.80*325.00*8.60	54.851	346.775
4293	312.80*330.00*8.60	55.656	349.033
4294	317.80*335.00*8.60	56.573	

现货O-型圈 O-RING IN STOCK

序号	规格	丁腈橡胶单价RMB	氟橡胶单价RMB
NO.	SPECIFICATION	NBR PRICE	FKM PRICE
4311	397.80*415.00*8.60	66.455	420.175
4312	402.80*420.00*8.60	67.272	430.612
4313	407.80*425.00*8.60	68.09	440.721
4314	412.80*430.00*8.60	71.908	454.494
4315	415.80*433.00*8.60	72.398	457.358
4316	422.80*440.00*8.60	74.543	464.04
4317	430.80*448.00*8.60	75.908	471.677
4318	432.80*450.00*8.60	76.974	475.03
4319	442.80*460.00*8.60	78.213	483.132
4320	447.80*465.00*8.60	80.631	490.957
4321	452.80*470.00*8.60	84.247	495.921
4322	462.80*480.00*8.60	85.084	502.224
4323	472.80*490.00*8.60	86.719	512.448
4324	482.80*500.00*8.60	91.033	521.317
4325	502.80*520.00*8.60	99.987	540.409
4326	517.80*535.00*8.60	122.77	554.728
4327	562.80*580.00*8.60	130.81	574.63
4328	572.80*590.00*8.60	133.099	580.666
4329	582.80*600.00*8.60	135.389	582.739
4330	60.00*78.00*9.00	18.396	96.125
4331	65.00*83.00*9.00	18.73	101.943
4332	70.00*88.00*9.00	19.466	114.515
4333	75.00*93.00*9.00	20.572	119.228
4334	76.00*94.00*9.00	20.226	120.281
4335	78.00*96.00*9.00	20.65	122.371
4336	80.00*98.00*9.00	20.96	124.462
4337	85.00*103.00*9.00	21.268	145.248
4338	90.00*108.00*9.00	22.3	147.923
4339	95.00*113.00*9.00	22.962	148.145
4340	105.00*123.00*9.00	23.896	150.599
4341	110.00*128.00*9.00	25.278	155.827
4342	115.00*133.00*9.00	26.298	161.642
4343	120.00*138.00*9.00	27.289	165.133
4344	121.00*139.00*9.00	27.526	175.333
4345	125.00*143.00*9.00	28.323	180.43
4346	130.00*148.00*9.00	29.329	185.657
4347	135.00*153.00*9.00	30.608	195.139
4348	140.00*158.00*9.00	31.316	209.197
4349	145.00*163.00*9.00	32.363	214.424
4350	150.00*168.00*9.00	32.664	219.652
4351	160.00*178.00*9.00	33.5	222.585
4352	164.00*182.00*9.00	34.75	225.288
4353	165.00*183.00*9.00	36.063	227.557
4354	170.00*188.00*9.00	37.5	229.552
4355	175.00*193.00*9.00	38.437	232.521
4356	180.00*198.00*9.00	41.619	239.502
4357	185.00*203.00*9.00	40.407	245.521
4358	189.00*207.00*9.00	40.591	250.03
4359	190.00*208.00*9.00	40.864	261.471
4360	195.00*213.00*9.00	41.028	266.698
4361	200.00*218.00*9.00	41.51	269.985
4362	202.00*220.00*9.00	41.893	270.921
4363	205.00*223.00*9.00	43.52	271.448
4364	210.00*228.00*9.00	44.5	272.167
4365	215.00*233.00*9.00	45.48	273.921
4366	217.00*235.00*9.00	45.92	274.921
4367	220.00*238.00*9.00	46.5	275.939
4368	226.00*244.00*9.00	47.68	276.921
4369	230.00*248.00*9.00	48.5	277.43
4370	240.00*258.00*9.00	50.2	278.412
4371	243.00*261.00*9.00	51.519	282.412
4372	250.00*268.00*9.00	52.15	285.375
4373	256.00*274.00*9.00	53.42	288.375
4374	260.00*278.00*9.00	54.2	302.654
4375	270.00*288.00*9.00	56.2	312.812
4376	280.00*298.00*9.00	58.2	319.793
4377	290.00*308.00*9.00	60.2	326.775
4378	295.00*313.00*9.00	61.5	335.246
4379	300.00*318.00*9.00	62.5	355.739
4380	350.00*368.00*9.00	72.32	379.139
4381	360.00*378.00*9.00	74.28	389.612
4382	370.00*388.00*9.00	76.22	405.321

序号	规格	丁腈橡胶单价RMB	氟橡胶单价RMB
NO.	SPECIFICATION	NBR PRICE	FKM PRICE
4383	470.00*488.00*9.00	107.62	554.204
4384	570.00*588.00*9.00	135.5	658.752
4385	620.00*638.00*9.00	145.6	711.025
4386	770.00*788.00*9.00	153.263	867.847
4387	59.00*78.00*9.50	18.996	105.434
4388	76.00*95.00*9.50	23.136	121.665
4389	81.00*100.00*9.50	24.354	127.076
4390	93.30*112.30*9.50	25.228	152.915
4391	98.42*117.42*9.50	26.265	180.157
4392	104.00*123.00*9.50	26.864	187.29
4393	113.00*132.00*9.50	27.586	197.774
4394	124.00*143.00*9.50	29.868	210.588
4395	128.00*147.00*9.50	30.289	220.367
4396	135.00*154.00*9.50	31.653	223.401
4397	150.00*169.00*9.50	33.639	239.502
4398	160.00*179.00*9.50	34.865	252.523
4399	162.00*181.00*9.50	35.187	254.852
4400	170.00*189.00*9.50	37.578	263.939
4401	210.00*229.00*9.50	48.982	310.766
4402	250.00*269.00*9.50	53.62	357.361
4403	66.00*85.20*9.60	16.819	112.239
4404	45.00*65.00*10.00	11.5	85.101
4405	48.00*68.00*10.00	13.837	89.176
4406	58.00*78.00*10.00	19.996	102.782
4407	60.00*80.00*10.00	15.076	105.401
4408	65.00*85.00*10.00	15.985	112.496
4409	70.00*90.00*10.00	17.194	118.915
4410	72.00*92.00*10.00	17.501	121.442
4411	74.00*94.00*10.00	17.804	124.06
4412	75.00*95.00*10.00	18.296	124.933
4413	76.00*96.00*10.00	19.166	124.933
4414	80.00*100.00*10.00	20.742	131.914
4415	81.00*101.00*10.00	21.348	133.005
4416	82.00*102.00*10.00	21.662	142.387
4417	84.00*104.00*10.00	22.045	144.933
4418	85.00*105.00*10.00	22.651	146.94
4419	90.00*110.00*10.00	23.166	148.656
4420	95.00*115.00*10.00	24.796	152.833
4421	98.42*118.42*10.00	25.996	157.247
4422	99.00*119.00*10.00	26.107	158.49
4423	100.00*120.00*10.00	26.503	159.776
4424	105.00*125.00*10.00	26.701	166.229
4425	108.00*128.00*10.00	26.882	170.101
4426	110.00*130.00*10.00	26.996	172.454
4427	113.00*133.00*10.00	27.599	182.93
4428	115.00*135.00*10.00	27.728	184.676
4429	120.00*140.00*10.00	28.596	191.657
4430	122.00*142.00*10.00	29.85	192.53
4431	125.00*145.00*10.00	30.153	194.548
4432	127.00*147.00*10.00	30.996	196.548
4433	128.00*148.00*10.00	31.138	197.193
4434	130.00*150.00*10.00	31.339	198.442
4435	135.00*155.00*10.00	31.651	203.003
4436	135.30*155.30*10.00	31.996	206.459
4437	136.00*156.00*10.00	32.996	216.363
4438	137.00*157.00*10.00	33.056	226.645
4439	138.00*158.00*10.00	33.183	236.348
4440	140.00*160.00*10.00	33.286	249.975
4441	145.00*165.00*10.00	33.376	256.97
4442	150.00*170.00*10.00	34.396	266.057
4443	152.00*172.00*10.00	35.306	268.939
4444	152.40*172.40*10.00	35.466	270.53
4445	156.00*176.00*10.00	36.213	273.921
4446	160.00*180.00*10.00	36.819	275.148
4447	162.00*182.00*10.00	37.819	277.767
4448	163.00*183.00*10.00	37.928	279.393
4449	164.00*184.00*10.00	38.122	280.185
4450	165.00*185.00*10.00	38.334	281.23
4451	166.00*186.00*10.00	38.624	283.221
4452	170.00*190.00*10.00	38.665	285.247
4453	172.00*192.00*10.00	38.678	287.393
4454	175.00*195.00*10.00	39.246	288.884

序号	规格	丁腈橡胶单价RMB	氟橡胶单价RMB
NO.	SPECIFICATION	NBR PRICE	FKM PRICE
4455	180.00*200.00*10.00	42.456	289.985
4456	188.00*208.00*10.00	42.986	290.848
4457	190.00*210.00*10.00	43.668	291.203
4458	200.00*220.00*10.00	44.509	292.421
4459	205.00*225.00*10.00	46.586	309.422
4460	210.00*230.00*10.00	48.334	328.521
4461	215.00*235.00*10.00	48.94	333.757
4462	219.00*239.00*10.00	49.547	340.739
4463	220.00*240.00*10.00	50.153	345.266
4464	224.00*244.00*10.00	51.126	358.945
4465	229.00*249.00*10.00	52.468	365.399
4466	230.00*250.00*10.00	53.639	368.793
4467	235.00*255.00*10.00	55.256	373.143
4468	240.00*260.00*10.00	57.275	375.739
4469	245.00*265.00*10.00	58.586	379.139
4470	250.00*270.00*10.00	59.699	382.702
4471	255.00*275.00*10.00	60.668	384.212
4472	260.00*280.00*10.00	61.517	388.175
4473	263.00*283.00*10.00	61.863	393.102
4474	270.00*290.00*10.00	62.729	398.157
4475	275.00*295.00*10.00	64.856	402.066
4476	280.00*300.00*10.00	65.154	406.121
4477	290.00*310.00*10.00	67.578	408.084
4478	300.00*320.00*10.00	68.366	415.102
4479	310.00*330.00*10.00	69.396	420.557
4480	320.00*340.00*10.00	71.896	432.853
4481	330.00*350.00*10.00	74.169	445.76
4482	350.00*370.00*10.00	78.826	451.575
4483	360.00*380.00*10.00	81.619	469.902
4484	370.00*390.00*10.00	83.421	547.389
4485	380.00*400.00*10.00	85.493	560.296
4486	390.00*410.00*10.00	87.68	565.812
4487	396.00*416.00*10.00	88.684	575.947
4488	400.00*420.00*10.00	89.498	585.284
4489	405.00*425.00*10.00	90.408	595.521
4490	420.00*440.00*10.00	91.946	611.925
4491	430.00*450.00*10.00	93.136	620.23
4492	442.00*462.00*10.00	98.294	640.32
4493	450.00*470.00*10.00	106.875	650.646
4494	455.00*475.00*10.00	116.976	666.521
4495	470.00*490.00*10.00	127.883	676.46
4496	480.00*500.00*10.00	132.732	689.367
4497	498.00*518.00*10.00	143.229	691.43
4498	520.00*540.00*10.00	153.263	714.266
4499	535.00*555.00*10.00	165.481	724.339
4500	580.00*600.00*10.00	179.145	742.193
4501	151.00*173.00*11.00	45.861	302.339
4502	177.00*199.00*11.00	55.156	340.739
4503	100.00*123.00*11.50	35.457	242.993
4504	105.00*128.00*11.50	37.732	262.503
4505	110.00*133.00*11.50	39.699	265.502
4506	115.00*138.00*11.50	42.225	272.993
4507	120.00*143.00*11.50	42.896	288.108
4508	125.00*148.00*11.50		

现货O-型圈 O-RING IN STOCK

序号	规格	丁腈橡胶单价RMB	氟橡胶单价RMB
NO.	SPECIFICATION	NBR PRICE	FKM PRICE
4527	260.00*283.00*11.50	77.196	527.083
4528	270.00*293.00*11.50	81.396	544.152
4529	278.00*301.00*11.50	87.68	550.812
4530	280.00*303.00*11.50	90.104	553.684
4531	290.00*313.00*11.50	91.996	568.292
4532	300.00*323.00*11.50	92.528	572.739
4533	310.00*333.00*11.50	93.796	582.431
4534	315.00*338.00*11.50	95.528	592.739
4535	320.00*343.00*11.50	98.589	601.648
4536	330.00*353.00*11.50	99.796	646.57
4537	340.00*363.00*11.50	101.996	667.648
4538	350.00*373.00*11.50	105.866	679.539
4539	360.00*383.00*11.50	107.796	697.779
4540	370.00*393.00*11.50	108.996	714.849
4541	380.00*403.00*11.50	111.196	731.919
4542	390.00*413.00*11.50	113.596	748.988
4543	400.00*423.00*11.50	116.776	752.375
4544	188.00*212.00*12.00	63.6	410.557
4545	127.20*151.44*12.12	48.589	305.83
4546	136.00*161.00*12.50	46.88	368.706
4547	298.00*323.00*12.50	100.996	695.417
4548	301.00*326.00*12.50	104.65	707.284
4549	324.00*349.00*12.50	110.396	747.853
4550	364.00*389.00*12.50	122.796	828.522
4551	184.15*209.55*12.70	73.196	480.25
4552	101.60*127.60*13.00	46.468	310.717

序号	规格	丁腈橡胶单价RMB	氟橡胶单价RMB
NO.	SPECIFICATION	NBR PRICE	FKM PRICE
4553	104.90*130.90*13.00	47.596	329.544
4554	107.90*133.90*13.00	48.396	336.088
4555	111.20*137.20*13.00	48.996	343.286
4556	114.50*140.50*13.00	49.396	350.484
4557	117.50*143.50*13.00	49.796	357.028
4558	120.00*146.00*13.00	50.596	362.482
4559	123.80*149.80*13.00	52.596	370.771
4560	127.00*153.00*13.00	54.346	375.684
4561	130.00*156.00*13.00	55.996	384.295
4562	135.00*161.00*13.00	59.195	395.739
4563	140.00*166.00*13.00	60.996	406.108
4564	149.00*175.00*13.00	62.225	410.084
4565	152.00*178.00*13.00	62.831	417.066
4566	160.00*186.00*13.00	64.996	450.102
4567	165.00*191.00*13.00	66.996	460.64
4568	168.00*194.00*13.00	69.396	467.184
4569	177.00*203.00*13.00	74.346	488.012
4570	184.00*210.00*13.00	74.796	502.085
4571	186.00*212.00*13.00	75.596	506.448
4572	190.00*216.00*13.00	76.196	515.173
4573	200.00*226.00*13.00	79.596	536.986
4574	203.00*229.00*13.00	80.196	547.83
4575	205.00*231.00*13.00	81.619	567.902
4576	215.00*241.00*13.00	84.196	582.739
4577	226.00*252.00*13.00	84.996	593.7
4578	227.00*253.00*13.00	85.696	618.775

序号	规格	丁腈橡胶单价RMB	氟橡胶单价RMB
NO.	SPECIFICATION	NBR PRICE	FKM PRICE
4579	235.00*261.00*13.00	86.996	623.331
4580	237.00*263.00*13.00	91.316	637.648
4581	244.00*270.00*13.00	91.996	642.963
4582	246.00*272.00*13.00	92.528	649.539
4583	255.00*281.00*13.00	96.396	650.484
4584	265.00*291.00*13.00	99.316	661.43
4585	268.50*294.50*13.00	101.996	686.405
4586	270.00*296.00*13.00	103.996	689.677
4587	271.00*297.00*13.00	106.07	699.466
4588	280.00*306.00*13.00	108.65	732.375
4589	290.00*316.00*13.00	114.796	744.448
4590	305.00*331.00*13.00	117.396	766.023
4591	318.00*344.00*13.00	122.596	784.379
4592	335.00*361.00*13.00	127.88	794.266
4593	350.00*376.00*13.00	130.196	824.181
4594	360.00*386.00*13.00	131.32	847.102
4595	370.00*396.00*13.00	135.796	867.807
4596	385.00*411.00*13.00	140.996	877.527
4597	400.00*426.00*13.00	144.696	886.921
4598	410.00*436.00*13.00	156.98	891.83
4599	420.00*446.00*13.00	159.35	951.648
4600	426.00*452.00*13.00	160.996	1029.96
4601	430.00*456.00*13.00	161.396	1038.69
4602	445.00*471.00*13.00	163.396	1091.28
4603	457.00*483.00*13.00	166.396	1097.58
4604	470.00*496.00*13.00	168.696	1125.94
4605	258.00*308.00*25.00	327	2348.01

5A



Size	Metric		UNIT PRICE	Size	Metric		UNIT PRICE
	d.	w.	USD		d.	w.	USD
006	2.9	1.78	0.0042	211	20.22	3.53	0.0251
007	3.68	1.78	0.0046	212	21.82	3.53	0.0267
008	4.47	1.78	0.0050	213	23.39	3.53	0.0282
009	5.29	1.78	0.0053	214	24.99	3.53	0.0297
010	6.07	1.78	0.0057	215	26.57	3.53	0.0312
011	7.65	1.78	0.0061	216	28.17	3.53	0.0331
012	9.25	1.78	0.0069	217	29.74	3.53	0.0347
110	9.19	2.62	0.0110	218	31.34	3.53	0.0362
111	10.77	2.62	0.0122	219	32.92	3.53	0.0377
112	12.37	2.62	0.0133	220	34.52	3.53	0.0419
113	13.94	2.62	0.0145	221	36.09	3.53	0.0457
114	15.54	2.62	0.0160	222	37.69	3.53	0.0499
115	17.12	2.62	0.0171	325	37.74	5.33	0.0762
116	18.72	2.62	0.0183	326	40.64	5.33	0.0800
210	18.64	3.53	0.0236	327	43.82	5.33	0.0838

现货O-型圈 O-RING IN STOCK

5B



Size	Metric		UNIT PRICE USD	Size	Metric		UNIT PRICE USD
	d.	w.			d.	w.	
P3	2.8	1.9	0.0042	G22	22	3	0.0259
P4	3.8	1.9	0.0050	P22.4	22.1	3.5	0.0267
P5	4.8	1.9	0.0053	G25	24.4	3.1	0.0286
P6	5.8	1.9	0.0057	P25	24.7	3.5	0.0297
P7	6.8	1.9	0.0061	P26	25.7	3.5	0.0305
P8	7.8	1.9	0.0065	G30	29.4	3.1	0.0347
P9	8.8	1.9	0.0069	P30	29.7	3.5	0.0350
P10A	9.8	2.4	0.0110	P32	31.7	3.5	0.0362
P11	10.8	2.4	0.0122	P34	33.7	3.5	0.0377
P12	11.8	2.4	0.0133	G35	34.4	3.1	0.0419
P14	13.8	2.4	0.0145	P36	35.7	3.5	0.0457
P16	15.8	2.4	0.0164	G40	39.4	3.1	0.0495
P18	17.8	2.4	0.0179	P40	39.7	3.5	0.0533
P20	19.8	2.4	0.0198	G45	44.4	3.1	0.0571
G20	20	3	0.0229	P48	47.7	3.5	0.0610

5C



Size	Metric		UNIT PRICE USD	Size	Metric		UNIT PRICE USD
	d.	w.			d.	w.	
P3	3.00	2.00	0.0042	G17	20.00	3.00	0.0248
P4	4.00	2.00	0.0046	G19	22.00	3.00	0.0274
P5	5.00	2.00	0.0050	G21	24.00	3.00	0.0286
P6	6.00	2.00	0.0053	G22	25.00	3.00	0.0297
P7	7.00	2.00	0.0057	G24	27.00	3.00	0.0309
P8	8.00	2.00	0.0061	G25	28.00	3.00	0.0324
P9	10.00	2.00	0.0065	G27	30.00	3.00	0.0335
P10A	10.00	2.50	0.0110	G28	32.00	3.00	0.0362
P11	11.00	2.50	0.0114	G29	33.00	3.00	0.0381
P12	12.00	2.50	0.0118	G31	35.00	3.00	0.0419
P13	14.00	2.50	0.0122	G32	36.00	3.00	0.0457
P14	16.00	2.50	0.0126	G34	38.00	3.00	0.0533
P15	17.00	2.50	0.0130	M34	38.00	4.00	0.0610
P16	19.00	2.50	0.0141	M37	41.00	4.00	0.0686
G16	19.00	3.00	0.0229	M40	44.00	4.00	0.0762

OIL SEAL FACTORY

现货O-型圈 O-RING IN STOCK

8B



Size	Inches		Metric		UNIT PRICE	Size	Inches		Metric		UNIT PRICE
	d.	w.	d.	w.	USD		d.	w.	d.	w.	USD
568-006	0.114	0.07	2.94	1.78	0.0042	568-211	0.796	0.139	20.23	3.53	0.0251
-008	0.176	0.07	4.47	1.78	0.0050	-212	0.859	0.139	21.82	3.53	0.0267
-010	0.239	0.07	6.07	1.78	0.0057	-213	0.921	0.139	23.39	3.53	0.0282
-011	0.301	0.07	7.65	1.78	0.0061	-214	0.984	0.139	24.99	3.53	0.0297
-012	0.364	0.07	9.25	1.78	0.0069	-215	1.046	0.139	26.57	3.53	0.0312
-014	0.489	0.07	12.42	1.78	0.0088	-216	1.109	0.139	28.17	3.53	0.0331
-110	0.362	0.103	9.19	2.62	0.0110	-217	1.171	0.139	29.74	3.53	0.0347
-111	0.424	0.103	10.77	2.62	0.0122	-218	1.234	0.139	31.34	3.53	0.0362
-112	0.487	0.103	12.37	2.62	0.0133	-219	1.296	0.139	32.92	3.53	0.0377
-113	0.549	0.103	13.94	2.62	0.0145	-220	1.359	0.139	34.52	3.53	0.0419
-114	0.612	0.103	15.54	2.62	0.0160	-221	1.421	0.139	36.09	3.53	0.0457
-115	0.674	0.103	17.12	2.62	0.0171	-222	1.484	0.139	37.69	3.53	0.0495
-116	0.737	0.103	18.72	2.62	0.0183	-223	1.609	0.139	40.87	3.53	0.0541
-117	0.799	0.103	20.29	2.62	0.0198	-224	1.734	0.139	44.04	3.53	0.0579
-118	0.862	0.103	21.89	2.62	0.0210	-225	1.859	0.139	47.22	3.53	0.0621
-210	0.734	0.139	18.64	3.53	0.0236	-226	1.984	0.139	50.39	3.53	0.0659

8C



Size	Metric		UNIT PRICE	Size	Metric		UNIT PRICE
	d.	w.	USD		d.	w.	USD
R-01	3.0	1.5	0.0042	R-17	20.0	3.5	0.0251
R-02	4.4	2.0	0.0050	R-18	22.0	3.5	0.0267
R-03	5.0	2.0	0.0053	R-19	23.5	3.5	0.0282
R-04	7.0	1.5	0.0061	R-20	25.0	3.5	0.0297
R-05	10.0	1.5	8.7619	R-21	26.5	3.5	0.0312
R-06	13.0	1.5	0.0088	R-22	28.0	3.5	0.0331
R-07	10.0	2.5	0.0110	R-23	30.0	3.5	0.0347
R-08	11.0	2.5	0.0122	R-24	31.0	3.5	0.0358
R-09	13.0	2.5	0.0137	R-25	33.0	3.5	0.0377
R-10	14.0	2.5	0.0145	R-26	34.5	3.5	0.0419
R-11	16.0	2.5	0.0164	R-27	36.0	3.5	0.0457
R-12	18.0	2.5	0.0175	R-28	38.0	3.5	0.0499
R-13	19.0	2.5	0.0190	R-29	41.0	3.5	0.0541
R-14	21.0	2.5	0.0198	R-30	44.0	3.5	0.0579
R-15	22.0	2.5	0.0210	R-31	47.0	3.5	0.0621
R-16	18.0	3.5	0.0229	R-32	50.0	3.5	0.0659



邢台山峰特种橡胶制品有限公司

地址：河北省邢台市任县河头工业区
 电话：0319-7576068 0319-7576088
 传真：0319-7576016
 手机：13903294678
 网址：<http://www.nqkoilseal.com>
 邮箱：nqkzyf@nqkoilseal.com



中文

Shanfeng Special Rubber Product Co., Ltd

Add: HETOU ECONOMIC DEVELOPMENT ZONE REN XIAN COUNTY
 XINGTAI CITY HEBEI PROVINCE CHINA
 Tel:0086-319-7576068 0086-319-7576088
 Fax:0086-319-7576016
 H.P. 0086-187 1390 8618
<http://www.nqksfoilseal.com>
 E-mail:nqkzyf@nqkoilseal.com



English